

S C H Ü S S L E R

Product catalogue

TOOL CLAMPING SYSTEMS



MADE IN GERMANY



SCHÜSSLER
the μ -maker



CONTENTS

HSK-A 63

HPC – Precision ER collet chuck HAWK EYE®	p. 14
HPC – Precision ER collet chuck HAWK EYE® „Mini“	p. 15
ER-Collet chuck	p. 16
ER-Collet chuck „Mini“	p. 17
ER-Collet chuck corrosion-resistant	p. 18
Endmill holder Weldon	p. 19
Endmill holder Weldon „Cool Tool“	p. 21
Endmill holder Weldon with 4 x „Cool Tool“ corrosion resistant	p. 22
Endmill holder Weldon – slim, long	p. 23
Endmill holder Whistle notch	p. 24
Shrink fit holder 4,5°	p. 25
Shrink fit holder 4,5° „Cool Tool“	p. 28
Shrink fit holder 4,5° long, slim	p. 30
Shrink fit holder 4,5° with 4 x „Cool Tool“ corrosion resistant	p. 31
Shrink fit holder 3°	p. 32
Thread shank adapter – conical form	p. 33
Thread shank adapter– cylindrical form	p. 34
Shell mill holder	p. 35
Shell mill holder „Cool Tool“	p. 36
Combi shell mill holder	p. 37
Morse taper adapter	p. 38
Short drill chuck	p. 39



PAGES 14–39

HSK-A 80

HPC – Precision ER collet chuck HAWK EYE®	p. 40
HPC – Precision ER collet chuck HAWK EYE® „Mini“	p. 41
ER-Collet chuck	p. 42
Endmill holder Weldon	p. 43
Shrink fit holder 4,5°	p. 44
Shell mill holder „Cool Tool“	p. 45



PAGES 40–45

HSK-A 100

HPC – Precision ER collet chuck HAWK EYE®Spannzangenfutter ER	p. 46
ER-Collet chuck	p. 47
ER-Collet chuck „Mini“	p. 48
ER-Collet chuck corrosion-resistant	p. 49
Endmill holder Weldon	p. 50
Endmill holder Weldon „Cool Tool“	p. 51
Endmill holder Weldon with 4 x „Cool Tool“ corrosion resistant	p. 52
Endmill holder Whistle Notch	p. 53
Shrink fit holder 4,5°	p. 54
Shrink fit holder 4,5° long, slim	p. 56
Shrink fit holder 4,5° „Cool Tool“	p. 57
Shrink fit holder 4,5° with 4 x „Cool Tool“ corrosion resistant	p. 58
Shrink fit holder 3°	p. 59
Shell mill holder	p. 60
Shell mill holder „Cool Tool“	p. 61
Combi shell mill holde	p. 62
Morse taper adapter	p. 63
Short drill chuck	p. 64

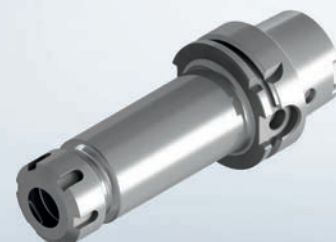

PAGES 46–64

HSK-A 40 and HSK-A 50

ER-Collet chuck	p. 65
Endmill holder Weldon	p. 66
Shrink fit holder 4,5°	p. 67
Shell mill holder	p. 68



PAGES 65–68

HSK-E 32, HSK-E 40 and HSK-E 50

HPC – Precision ER collet chuck HAWK EYE®	p. 71
HPC – Precision ER collet chuck HAWK EYE® „Mini“	p. 72
ER-Collet chuck	p. 73
Shrink fit holder 4,5°	p. 74
Shrink fit holder 3°	p. 76/78
Shrink fit holder 3° extra slim, short	p. 78

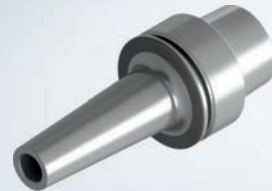

PAGES 71–78

HSK-F 63

HPC – Precision ER collet chuck HAWK EYE®	p. 81
ER-Collet chuck	p. 82
Shrink fit holder 4,5°	p. 83
Shell mill holder „Cool Tool“	p. 84



PAGES 81–84

SK 40 ISO 7388-1 AD/AF

HPC – Precision ER collet chuck HAWK EYE®	p. 87
HPC – Precision ER collet chuck HAWK EYE® „Mini“	p. 88
ER-Collet chuck	p. 89
ER-Collet chuck „Mini“	p. 90
ER-Collet chuck corrosion-resistant	p. 91
Endmill holder Weldon	p. 92
Endmill holder Weldon „Cool Tool“	p. 93
Endmill holder Weldon with 4 x „Cool Tool“ corrosion resistant	p. 94
Endmill holder Weldon – slim, long version	p. 95
Shrink fit holder 4,5°	p. 96
Shrink fit holder 4,5° „Cool Tool“	p. 99
Shrink fit holder 4,5° slim / „Cool Tool“	p. 101
Shrink fit holder 4,5° with 4 x „Cool Tool“ corrosion resistant	p. 102
Shrink fit holder 3°	p. 103
Thread shank adapter – conical form	p. 104
Thread shank adapter– cylindrical form	p. 105
Shell mill holder „Cool Tool“	p. 106
Combi shell mill holder	p. 107
Short drill chuck	p. 108

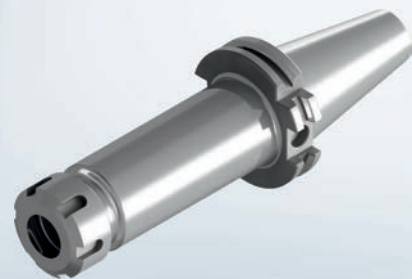

PAGES 87–108

SK 50 ISO 7388-1 AD/AF

HPC – Precision ER collet chuck HAWK EYE®	p. 109
ER-Collet chuck	p. 110
ER-Collet chuck „Mini“	p. 111
Endmill holder Weldon	p. 112
Endmill holder Weldon „Cool Tool“	p. 113
Shrink fit holder 4,5°	p. 114
Shrink fit holder 4,5° „Cool Tool“	p. 117
Shrink fit holder 4,5° with 4x „Cool Tool“ corrosion resistant	p. 119
Shell mill holder „Cool Tool“	p. 120
Combi shell mill holder	p. 121
Short drill chuck	p. 122

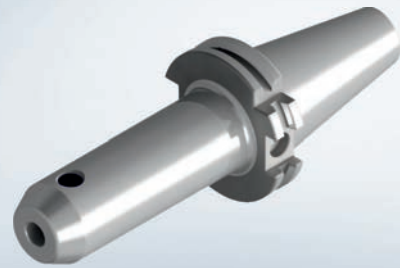

PAGES 109–122

MAS-BT 30 ISO 7388-2

HPC – Precision ER collet chuck HAWK EYE® / ER-„Mini“	p. 124
ER-Collet chuck	p. 125
Shrink fit holder 4,5°	p. 126
Shrink fit holder 4,5° „Cool Tool“	p. 127
Shell mill holder „Cool Tool“	p. 128

MAS-BT 40 ISO 7388-2 JD/JF

HPC – Precision ER collet chuck HAWK EYE®	p. 129
HPC – Precision ER collet chuck HAWK EYE® „Mini“	p. 130
ER-Collet chuck	p. 131
ER-Collet chuck „Mini“	p. 132
Endmill holder Weldon	p. 133
Shrink fit holder 4,5°	p. 134
Shrink fit holder 4,5° „Cool Tool“	p. 136
Shrink fit holder 3°	p. 137
Shell mill holder „Cool Tool“	p. 138
Combi shell mill holder	p. 139
Short drill chuck	p. 140

MAS-BT 50 ISO 7388-2 JD/JF

HPC – Precision ER collet chuck HAWK EYE®	p. 141
ER-Collet chuck	p. 142
Endmill holder Weldon	p. 143
Shrink fit holder 4,5° / „Cool Tool“	p. 144
Shell mill holder „Cool Tool“	p. 146
Combi shell mill holder	p. 147
Short drill chuck	p. 148

BT DOUBLE CONTACT – BTD

BTD 30

HPC – Precision ER collet chuck HAWK EYE® / ER-„Mini“	p. 149
ER-Collet chuck - BT double contact - BTD	p. 150
Shrink fit holder 4,5° - BT double contact - BTD	p. 151
Shell mill holder „Cool Tool“ - BT double contact - BTD	p. 152

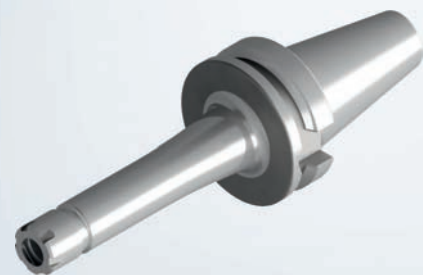

PAGES 124–152

BTD 40

ER-Collet chuck - BT double contact - BTD	p. 153
Endmill holder Weldon - BT double contact - BTD	p. 154
Shrink fit holder 4,5° - BT double contact - BTD	p. 155
Shell mill holder „Cool Tool“ - BT double contact - BTD	p. 156

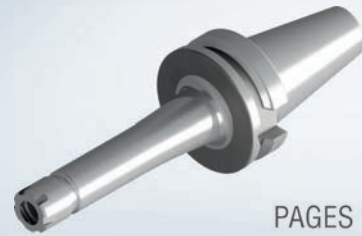

PAGES 153–156

POLYGON SHANK CORUM C4, C5, C6, C8

HPC – Precision ER collet chuck HAWK EYE®	p. 159
ER-Collet chuck	p. 160
ER-Collet chuck „Mini“	p. 162
Endmill holder Weldon	p. 163
Endmill holder Weldon „Cool Tool“	p. 164
Endmill holder Whistle Notch	p. 166
Shrink fit holder 4,5°	p. 167
Shrink fit holder 4,5° „Cool Tool“	p. 168
Shell mill holder „Cool Tool“	p. 172



PAGES 159–172

ACCESSORIES

Collet chuck extensions	p. 174
Shrink fit extensions	p. 175
Pull studs	p. 178
Coolant tubes + wrenches	p. 182
Taper cleaners	p. 182
ER-Collets 5 μ	p. 183
ER-Collets 2 μ	p. 183
Sealed collets	p. 184
Sealable clamping nuts	p. 185
Sealings discs	p. 185
Ball bearing wrenches + attachment	p. 186
Torque wrenches	p. 187
Clamping nuts	p. 187
Wrenches	p. 188
Others	p. 189

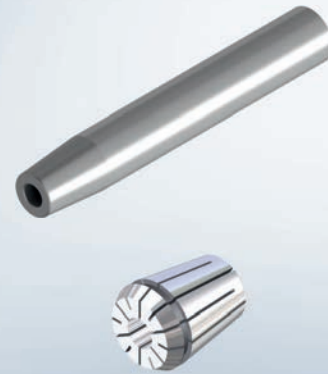

PAGES 174–191



RESPONSIBILITY FOR MEN AND THE ENVIRONMENT.

TOOL HOLDING SYSTEMS SUSTAINABLE PRODUCED IN GERMANY.



- ✓ We use 100% electricity produced by water power plants
- ✓ We operate photovoltaic systems for own power consumption
- ✓ We heat our buildings CO₂-neutral with wooden pellets
- ✓ We use systems for heat recovery of our facilities
- ✓ We are a member of the sustainability initiative “Blue Competence”





MADE IN GERMANY

QUALITY FEATURES

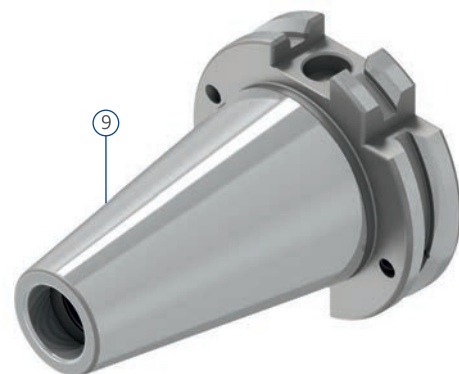
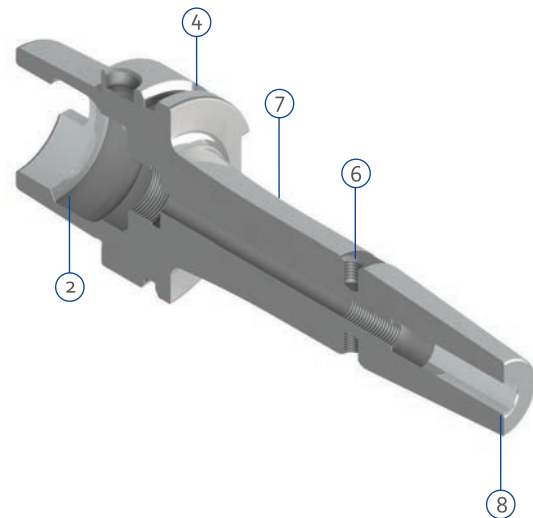
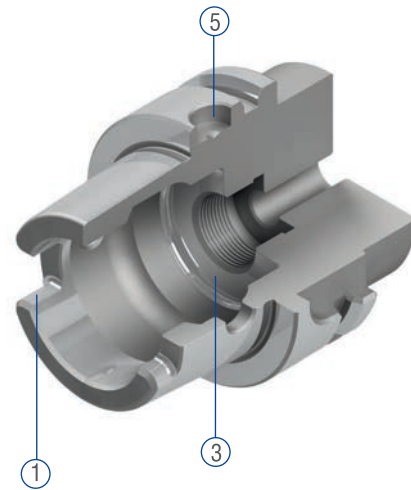
- ① **Hard reworked drive slots on HSK-taper guarantees:**
 - 100% symmetry of the HSK-slots
 - perfect seat and torque transfer in machine spindle
- ② **Hard reworked HSK-shoulder guarantees:**
 - perfect runout of clamping shoulder (max. 10 μ : 5 times more accurate than DIN)
 - highest runout accuracy
 - maximum clamping force in spindle
 - maximum radial rigidity
- ③ **Hard reworked HSK-discharge surface guarantees:**
 - safe release of HSK at tool change
- ④ **All toolholders fine balanced to G2,5 25.000 or max. unbalance \leq 1 gmm, for:**
 - smooth and bearing protecting spindle run
 - longer spindle life cycle
 - maximum tool life
 - better milling surface
- ⑤ **HSK-A, ISO 7388-1 and CORUM have included the bore for disk-chip as standard**
- ⑥ **Standard shrink fit chucks with 4-threads for supplementary fine balancing**
- ⑦ **Long version with transition radius for increased radial rigidity**
- ⑧ **Long shrink fit for maximum clamping force with insertion radius only**
- ⑨ **All tapers in tolerance quality AT3**

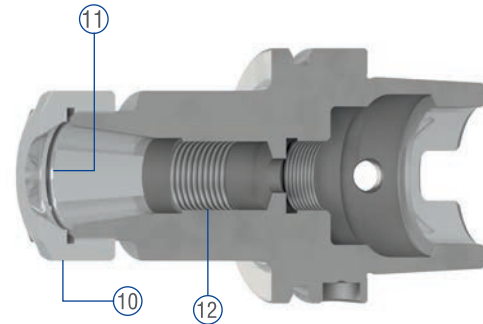

- ⑩ Fine balanced and hardened clamping nut
- ⑪ Radius transfer to ER-taper maintains accuracy of the collet
- ⑫ Big insertion depth for tools with long shank



Runout tolerance of the different toolholder types:

Toolholder type:	Runout A < 160	Runout A ≥ 160
Endmill holder Weldon, Collet cuck, Shrink fit holder, Endmill holder Whistle Notch	≤ 3 μ	≤ 4 μ
Shell mill holder, Combi shell mill holder	≤ 6 μ	≤ 6 μ
Morse taper adapter	≤ 8 μ	

IDENTIFICATION WITH RFID-CHIP

Schüssler offers you the opportunity to supply our tool holders in standard size (ø 10 x 4,5 mm) with data-chip. The following interfaces are already prepared for assembling the data chip:

- HSK-A Hollow shank taper DIN 69893 / ISO 12164
- SK Steep taper DIN 69871 / ISO 7388-1
- PSC (CORUM) Polygon interface ISO 26623-1
- BT Steep taper MAS-BT / ISO 7388-2

Various types and suppliers are available (low frequency / high frequency).

Our service: Data chip, procurement, assembling and additional fine balancing.

Please send your enquiries to our sales team: sales@k-schuessler.de.



Order No.: Specification:

735-31	RFID chip Balluf BIS C-122-04/L
735-32	RFID chip Balluf BIS M-122-02/A
735-33	RFID chip Balluf BIS C-122-11/L
735-34	RFID chip Siemens MDS D421
735-35	RFID chip Balluf BIS C-122-05/L
735-36	Siemens chip MDS E623
735-37	RFID chip Mazak ID40
735-61	SCHÜSSLER code chip for tool identification



LOW INVEST, HIGH RETURN



The cost of tool holders is less than 1 % of the total production costs of a workpiece and therefore nearly insignificant. But they offer enormous savings potential: because high quality in the tool holding interface enables you to:

- ⊖ increase tool life significantly,
- ⊖ improve machining processes in terms of productivity and workpiece quality,
- ⊖ extend the life of the spindle.

As our calculation example shows, the use of high-quality SCHÜSSLER tool holders lead to significant savings in the tool costs. Even one tool holder can reduce the cost of the tools used in it by more than 6.000 €, with an additional investment of less than 50 €. Who invests in SCHÜSSLER, benefits from a top return!

Schüssler – the solution for profitable, successful machining

However, the actual savings potential in relation to your entire manufacturing process is a lot higher than the 6.500 € per tool holder. Because SCHÜSSLER quality also contributes to reducing machine and labour costs. Additional, you increase your productivity by:

- ⊖ Higher machine availability due to longer spindle service life thanks to the highest balancing quality of the tool holders.
- ⊖ Bigger cutting volume and thus faster processes by the optimal use of the modern HPC tools.

	„Noname“	SCHÜSSLER
Product:	HSK-A 63 ER-Collet chuck with standard collets, clamping diameter Ø16 mm	Precision-ER collet chuck with high-performance nut and with precision collet, clamping diameter Ø16 mm
Price:	85,- €	130,- €
Usage time:	5 years	5 years
Tool costs: (Solid carbide endmill, coated, Ø 16 mm)	130,- €/piece	130,- €/piece
Consumption:	2 endmills per week = 96 mills per year	10 % tool life improvement: 1,8 milling cutters per week = 86 milling cutters per year
Tool costs / year:	12.480,- €	11.180,- €
Tools costs / 5 years:	62.400,- €	55.900,- €
Savings:		6500,- € (for 45,- € additional costs)

Possible tool cost savings: per used SCHÜSSLER tool holder during a working life of 5 years.

TOOL HOLDERS

DIN 68893-1, HSK-A 63, HSK-A 80,
HSK-A 100, HSK-A 40 AND HSK-A 50

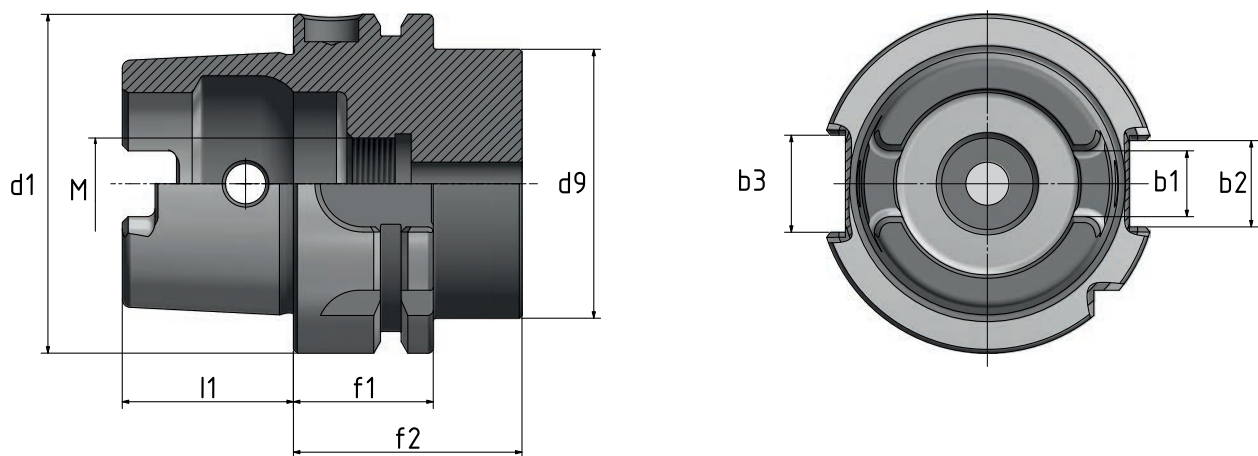

HSK	d1	d9 max.	l1	f1	f2 min.	b1	b2	b3	M
40	40	34	20	20	35	8,05	9	11	M12x1
50	50	42	25	26	42	10,54	12	14	M16x1
63	63	53	32	26	42	12,54	16	18	M18x1
80	80	68	40	26	42	16,04	18	20	M20x1,5
100	100	88	50	29	45	20,02	20	22	M24x1,5

HPC – Precision ER collet chuck HAWK EYE®

Application: For clamping tools with cylindrical shank in collets ER.

Technical Design: Due to high precision taper tolerances of the ER-Inner taper and the collet taper max. runout of $\leq 5 \mu$ at $2,5 \times D$, subject the usage of our HP 2μ ER collets. The deep fit of the collet inside the chuck combined with a surface treated clamping nut achieves more than double clamping force compared to standard ER collet chuck. HAWK EYE® has an enforced body for max. radial rigidity. The patented special design of HAWK EYE® chuck is only suitable to clamp nominal diameters of the collet used.

Includes: Special clamping nut.

Accessories: See page 183.

FINE BALANCED
G 2,5 at 25.000^{min-1} or max.
residual imbalance ≤ 1 gmm

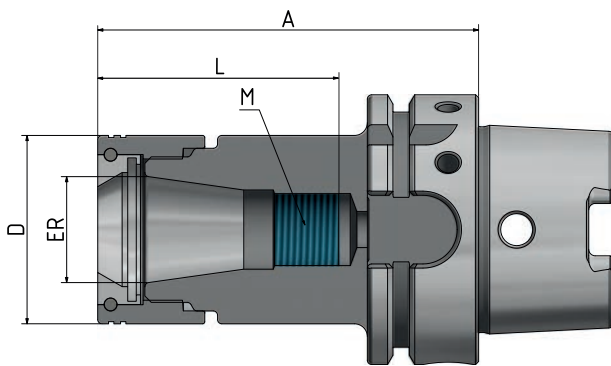

Fig. shows A = 130

Order No.	HSK	ER	D	A	Clamping range	L	M	Version
606332-002	63	16	34	75	1–10	32	-	Extra short
606332-003	63	20	38	75	1–13	36	-	Extra short
606332-004	63	25	44	75	1–16	39	-	Extra short
606332-005	63	32	52	75	2–20	47	-	Extra short
606332-006	63	40	62	85	4–26	53	-	Extra short
606332-02	63	16	34	100	1–10	58	M11x1	Short
606332-04	63	25	44	100	1–16	69	M18x1,5	Short
606332-05	63	32	52	100	2–20	73	M24x1,5	Short
606332-06	63	40	62	120	4–26	87	M28x1,5	Short
606332-52	63	16	34	130	1–10	58	M11x1	Long
606332-54	63	25	44	130	1–16	69	M18x1,5	Long
606332-55	63	32	52	130	2–20	78	M24x1,5	Long
606332-62	63	16	34	160	1–10	58	M11x1	Extra long
606332-64	63	25	44	160	1–16	69	M18x1,5	Extra long
606332-65	63	32	52	160	2–20	78	M24x1,5	Extra long



Sealed versions
see pages 186, 187.

HSK-A 63

HPC – Precision ER collet chuck HAWK EYE® „Mini“

Application: For clamping tools with cylindrical shank in collets ER.

Technical Design: Due to high precision taper tolerances of the ER-Inner taper and the collet taper max. runout of $\leq 5 \mu$ at $2,5 \times D$, subject the usage of our HP 2 μ ER collets. The deep fit of the collet inside the chuck combined with a surface treated clamping nut achieves more than double clamping force compared to standard ER collet chuck. HAWK EYE® has an enforced body for max. radial rigidity. The patented special design of HAWK EYE® chuck is only suitable to clamp nominal diameters of the collet used.

Includes: Special clamping nut.

Accessories: See page 183.

FINE BALANCED
G 2,5 at 25.000^{min}-1 or max.
residual imbalance ≤ 1 gmm

HSK-A 63

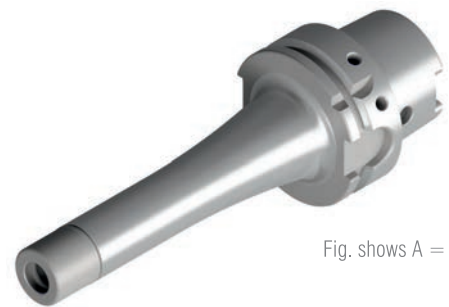
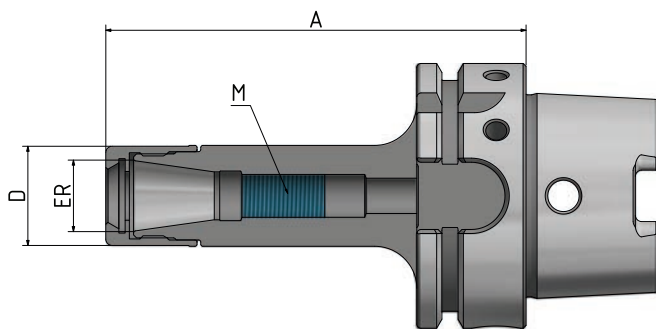

Fig. shows A = 160

Order No.	HSK	ER	D	A	Clamping range	L	M	Version
606334-01	63	11	16	100	1–7	48	M8x1	Short
606334-02	63	16	24	100	1–10	61	M11x1	Short
606334-61	63	11	16	160	1–7	48	M8x1	Extra long
606334-62	63	16	24	160	1–10	61	M11x1	Extra long



Sealed versions
see pages 186, 187.

ER-Collet chuck

Application: For clamping tools with cylindrical shank in collets ER.

Technical Design: Runout of outer taper to inner taper $\leq 0,003$ mm.
Due to adjusted taper tolerances of the ER-Inner taper and the collet taper max. runout of $\leq 8 \mu$ at 2,5 X D.

Includes: Clamping nut.

Accessories: See page 183.

FINE BALANCED
G 2,5 at 25.000^{min}-1 or max.
residual imbalance ≤ 1 gmm

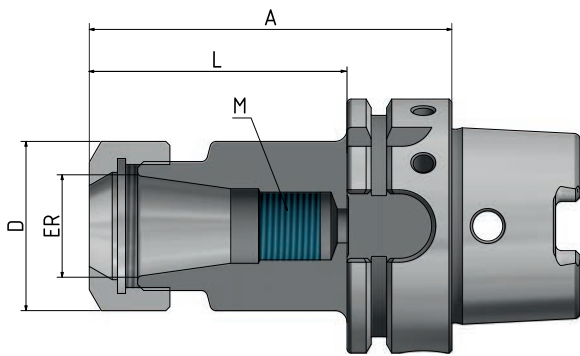
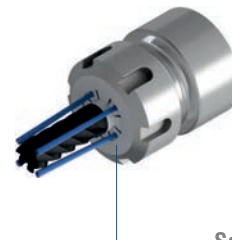

Fig. shows A = 130

Order No.	HSK	ER	D	Clamping range			M	Version
				A	L	M		
606302-006	63	11	19	75	1-7	59	-	Extra short
606302-001	63	16	28	75	1-10	45	-	Extra short
606302-007	63	20	34	75	1-13	42	-	Extra short
606302-002	63	25	42	75	1-16	47	-	Extra short
606302-003	63	32	50	75	2-20	48	-	Extra short
606302-004	63	40	63	85	4-26	54	-	Extra short
606302-01	63	16	28	100	1-10	65	M11x1	Short
606302-07	63	20	34	100	1-13	71	M14x1	Short
606302-02	63	25	42	100	1-16	73	M18x1,5	Short
606302-03	63	32	50	100	2-20	75	M24x1,5	Short
606302-04	63	40	63	120	4-26	95	M28x1,5	Short
606302-32	63	16	28	130	1-10	65	M11x1	Long
606302-37	63	20	34	130	1-13	71	M14x1	Long
606302-34	63	25	42	130	1-16	75	M18x1,5	Short
606302-35	63	32	50	130	2-20	82	M24x1,5	Long
606302-36	63	40	63	130	4-26	96	M28x1,5	Long
606302-011	63	16	28	160	1-10	65	M11x1	Extra long
606302-021	63	25	42	160	1-16	75	M18x1,5	Extra long
606302-031	63	32	50	160	2-20	82	M24x1,5	Extra long
606302-041	63	40	63	160	4-26	96	M28x1,5	Extra long
606302-012	63	16	28	200	1-10	65	M11x1	Extra long
606302-022	63	25	42	200	1-16	75	M18x1,5	Extra long
606302-032	63	32	50	200	2-20	82	M24x1,5	Extra long



Sealed versions
see pages 186, 187.

HSK-A 63

ER-Collet chuck „Mini“

Application: For clamping tools with cylindrical shank in collets ER.

Technical Design: Runout of outer taper to inner taper $\leq 0,003$ mm.
Due to adjusted taper tolerances of the ER-Inner taper and the collet taper max. runout of $\leq 8 \mu$ at $2,5 \times D$.

Includes: Clamping nut.

Accessories: See page 183.

FINE BALANCED
G 2,5 at 25.000^{min}-1 or max.
residual imbalance ≤ 1 gmm

HSK-A 63

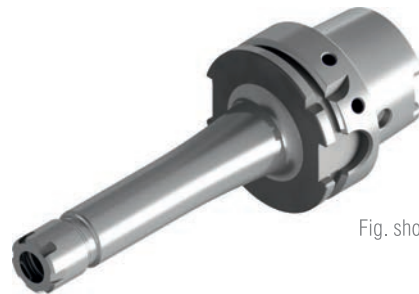
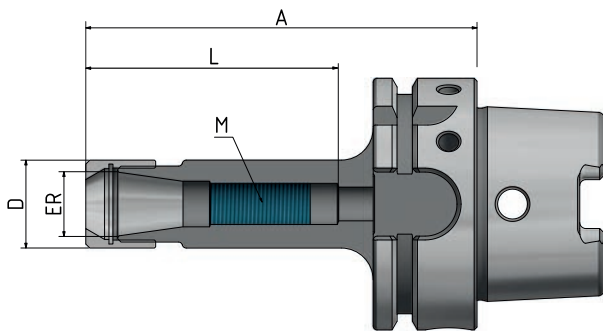

Fig. shows A = 130

Order No.	HSK	ER	D	A	Spannb.	L	M	Version
606302-41	63	11	16	70	1-7	44	M8x1	Extra short
606302-43	63	16	22	70	1-10	45	M11x1	Extra short
606302-21	63	11	16	100	1-7	49	M8x1	Short
606302-23	63	16	22	100	1-10	65	M11x1	Short
606302-25	63	20	28	100	1-13	71	M14x1	Short
606302-27	63	25	35	100	1-16	73	M18x1,5	Short
606302-51	63	11	16	130	1-7	49	M8x1	Long
606302-52	63	16	22	130	1-10	65	M11x1	Long
606302-53	63	20	28	130	1-13	71	M14x1	Long
606302-54	63	25	35	130	1-16	75	M18x1,5	Long
606302-22	63	11	16	160	1-7	49	M8x1	Extra long
606302-24	63	16	22	160	1-10	65	M11x1	Extra long
606302-26	63	20	28	160	1-13	71	M14x1	Extra long
606302-28	63	25	35	160	1-16	75	M18x1,5	Extra long



Sealed versions
see pages 186, 187.

ER-Collet chuck – Corrosion resistant

Application: For clamping tools with cylindrical shank in collets ER.

Technical Design: The entire front area of the tool holder is corrosion resistant.
Runout of outer taper to inner taper $\leq 0,003$ mm.
Due to adjusted taper tolerances of the ER-Inner taper and the collet taper max. runout of $\leq 8\mu$ at 2,5 X D.

Includes: Clamping nut.

Accessories: See page 183.

FINE BALANCED
G 2,5 at 25.000^{min}-1 or max.
residual imbalance ≤ 1 gmm

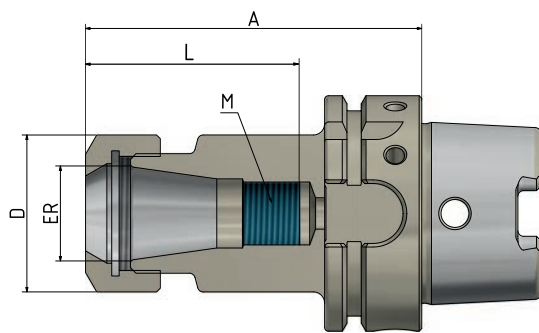

Corrosion resistant

Order No.	HSK	ER	D	A	Clamping range	L	M	Version
6063028-01	63	16	28	100	1-10	65	M11x1	Short
6063028-02	63	25	42	100	1-16	73	M18x1,5	Short
6063028-03	63	32	50	100	2-20	75	M24x1,5	Short
6063028-04	63	40	63	120	4-26	95	M28x1,5	Short



Sealed versions
see pages 186, 187.

HSK-A 63

Endmill holder Weldon

- Application:** For clamping tools with cylindrical shank according to DIN 1835B/6359HB.
- Technical Design:** Runout of outer taper to $D1 \leq 0,003$ mm.
Tolerance of bore H4 (more accurate as DIN).
- Includes:** Clamping screw, from $\varnothing 25$ with 2 clamping screws.
- Accessories:** See page 188.

FINE BALANCED
G 2,5 at 25.000^{min-1} or max.
residual imbalance ≤ 1 gmm

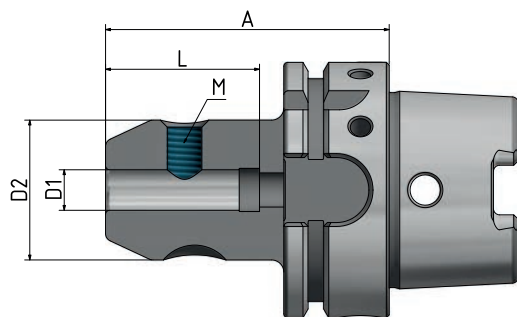

Fig. shows A = 120



Fig. shows $\varnothing 25$ with 2 clamping screws

Order No.	HSK	D1	A	D2	L	M	Version
606304-01	63	6	65	25	35	M6	Short
606304-02	63	8	65	28	35	M8	Short
606304-03	63	10	65	35	41	M10	Short
606304-04	63	12	80	42	48	M12	Short
606304-05	63	14	80	44	48	M12	Short
606304-06	63	16	80	48	51	M14	Short
606304-07	63	18	80	50	51	M14	Short
606304-08	63	20	80	52	53	M16	Short
606304-10	63	25	110	65	60	M18x2	Short
606304-11	63	32	110	72	64	M20x2	Short
606304-12	63	40	125	80	80	M20x2	Short
606304-21	63	6	100	25	35	M6	Long
606304-22	63	8	100	28	35	M8	Long
606304-23	63	10	100	35	41	M10	Long
606304-24	63	12	100	42	48	M12	Long
606304-25	63	14	100	44	48	M12	Long
606304-26	63	16	100	48	51	M14	Long
606304-27	63	18	100	50	51	M14	Long
606304-28	63	20	100	52	53	M16	Long

Endmill holder Weldon (Continuation)

HSK-A 63

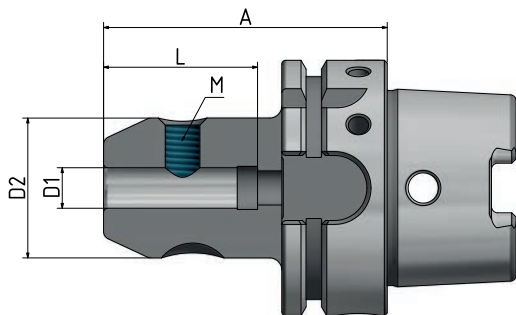

Fig. shows A = 120



Fig. shows \varnothing 25 with 2 clamping screws

Order No.	HSK	D1	A	D2	L	M	Version
606304-31	63	6	120	25	35	M6	Long
606304-32	63	8	120	28	35	M8	Long
606304-33	63	10	120	35	41	M10	Long
606304-34	63	12	120	42	48	M12	Long
606304-35	63	14	120	44	48	M12	Long
606304-36	63	16	120	48	51	M14	Long
606304-37	63	18	120	50	51	M14	Long
606304-38	63	20	120	52	53	M16	Long
606304-61	63	6	160	25	35	M6	Extra long
606304-62	63	8	160	28	35	M8	Extra long
606304-63	63	10	160	35	41	M10	Extra long
606304-64	63	12	160	42	48	M12	Extra long
606304-65	63	14	160	44	48	M12	Extra long
606304-66	63	16	160	48	51	M14	Extra long
606304-67	63	18	160	50	51	M14	Extra long
606304-68	63	20	160	52	53	M16	Extra long
606304-69	63	25	160	65	60	M18x2	Extra long
606304-70	63	32	160	72	64	M20x2	Extra long

HSK-A 63

Endmill holder Weldon „Cool Tool“

- Application:** Particularly suitable for tools without internal coolant, and for machining at difficult positions with bad chip removal.
- Technical Design:** Two holes in the toolholder lead the coolant directly to the cutting edge. Runout of outer taper to $D1 \leq 0,003$ mm. Tolerance of bore H4 (more accurate as DIN).
- Includes:** Clamping screw (from $\varnothing 25$ with 2 clamping screws) and 2 x M3-screws to plug the coolant holes if needed.
- Accessories:** See page 188.

 **FINE BALANCED**
G 2,5 at 25.000^{min}-1 or max.
residual imbalance ≤ 1 gmm

HSK-A 63

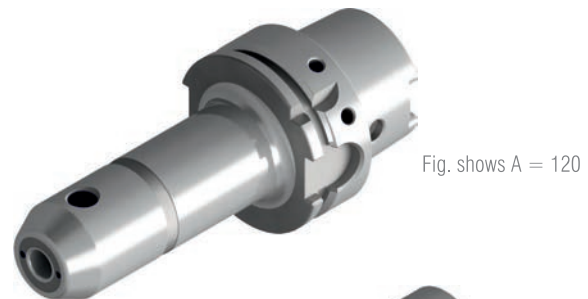
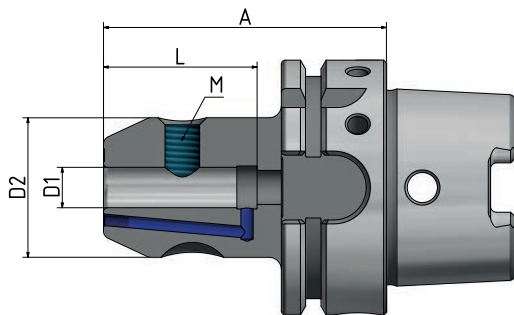

Order No.	HSK	D1	A	D2	L	M	Version
6063041-01	63	6	65	25	35	M6	Short
6063041-02	63	8	65	28	35	M8	Short
6063041-03	63	10	65	35	41	M10	Short
6063041-04	63	12	80	42	48	M12	Short
6063041-05	63	14	80	44	48	M12	Short
6063041-06	63	16	80	48	51	M14	Short
6063041-07	63	18	80	50	51	M14	Short
6063041-08	63	20	80	52	53	M16	Short
6063041-10	63	25	110	65	60	M18x2	Short
6063041-11	63	32	110	72	64	M20x2	Short
6063041-31	63	6	120	25	35	M6	Long
6063041-32	63	8	120	28	35	M8	Long
6063041-33	63	10	120	35	41	M10	Long
6063041-34	63	12	120	42	48	M12	Long
6063041-35	63	14	120	44	48	M12	Long
6063041-36	63	16	120	48	51	M14	Long
6063041-37	63	18	120	50	51	M14	Long
6063041-38	63	20	120	52	53	M16	Long

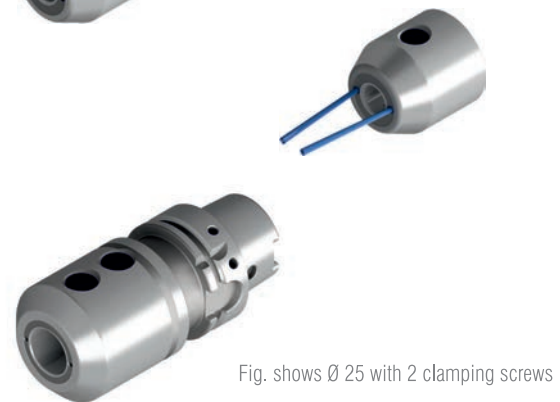

Order No.	HSK	D1	A	D2	L	M	Version
6063041-61	63	6	160	25	35	M6	Extra long
6063041-62	63	8	160	28	35	M8	Extra long
6063041-63	63	10	160	35	41	M10	Extra long
6063041-64	63	12	160	42	48	M12	Extra long
6063041-65	63	14	160	44	48	M12	Extra long
6063041-66	63	16	160	48	51	M14	Extra long
6063041-67	63	18	160	50	51	M14	Extra long
6063041-68	63	20	160	52	53	M16	Extra long

Endmill holder Weldon with 4 x „Cool Tool“ – Corrosion resistant

- Application:** Particularly suitable for tools without internal coolant, and for machining at difficult positions with bad chip removal.
- Technical Design:** The entire front area of the tool holder is corrosion resistant.
Runout of outer taper to inner taper $\leq 0,003$ mm.
Tolerance of bore H4 (more accurate as DIN).
Four holes in the toolholder lead the coolant directly to the cutting edge.
- Includes:** Clamping screw and 4 x M3-screws to plug the coolant holes if needed.
- Accessories:** See page 188.

FINE BALANCED
G 2,5 at 25.000^{min}-1 or max.
residual imbalance ≤ 1 gmm

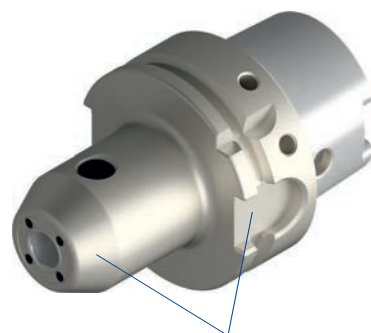
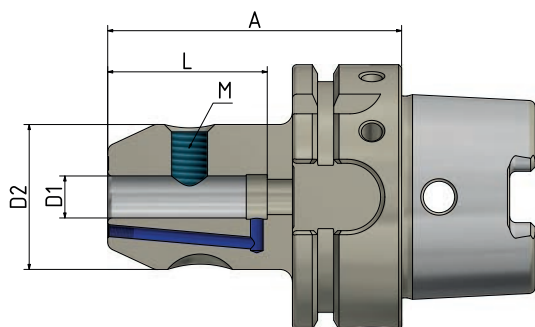

Corrosion resistant

Order No.	HSK	D1	A	D2	L	M	Version
6063048-018	63	6	65	25	35	M6	Short
6063048-028	63	8	65	28	35	M8	Short
6063048-038	63	10	65	35	41	M10	Short
6063048-048	63	12	80	42	48	M12	Short
6063048-068	63	16	80	48	51	M14	Short
6063048-088	63	20	80	52	53	M16	Short



4-fold Cool Tool

HSK-A 63

Endmill holder Weldon – slim, long

Application: For clamping tools with cylindrical shank according to DIN 1835B/6359HB and DIN 1835E/6359HE.

Technical Design: Runout of outer taper to inner taper $\leq 0,003$ mm.
Tolerance of bore H4 (more accurate as DIN).

Includes: Special clamping screw (with ball head) and set screw (for internal cooling).

Accessories: See page 188.

FINE BALANCED
G 6,3 at 8.000^{min-1}

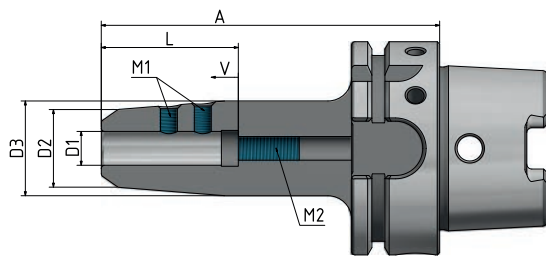

Order No.	HSK	D1	A	D2	D3	L	M1	M2	Version
606327-01	63	6	100	13	24	36,5	M6	M5	Long
606327-03	63	8	100	15	26	36,5	M6	M6	Long
606327-05	63	10	100	16	28	40,5	M6	M8x1	Long
606327-07	63	12	100	17	29	45,5	M6	M10x1	Long

Endmill holder Whistle-Notch

Application: For clamping tools with cylindrical shank according to DIN 1835E/6359HE.

Technical Design: Runout of outer taper to $D1 \leq 0,003$ mm.
Tolerance of bore H4 (more accurate as DIN).

Includes: Clamping screw (from $\varnothing 25$ with 2 clamping screws) and set screw.

Accessories: See page 188.

FINE BALANCED
G 6,3 at $8.000^{mm^{-1}}$

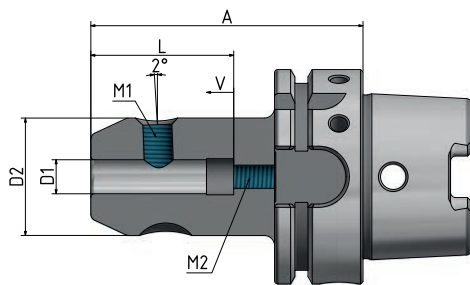

Order No.	HSK	D1	A	D2	L	M1	M2	V	Version
606309-01	63	6	80	25	36,5	M6	M5	10	Short
606309-02	63	8	80	28	36,5	M8	M6	10	Short
606309-03	63	10	80	35	40,5	M10	M8	10	Short
606309-04	63	12	90	42	45,5	M12	M10	10	Short
606309-05	63	14	90	44	45,5	M12	M10	10	Short
606309-06	63	16	100	48	48,5	M14	M12	10	Short
606309-07	63	18	100	50	48,5	M14	M12	10	Short
606309-08	63	20	100	52	50,5	M16	M16	10	Short
606309-10	63	25	110	65	56,5	M18x2	M20	10	Short
606309-11	63	32	110	72	60,5	M20x2	M20	10	Short



Fig. shows $\varnothing 25$ with 2 clamping screws

HSK-A 63

Shrink fit holder 4,5°

Application: For clamping tools with cylindrical shank of solid carbide or HSS, tol. h6.

Technical Design: Made of special heat resistant steel. Suitable for inductive shrinking unit. With four additional threads for supplementary fine balancing. Runout of outer taper to $D1 \leq 0,003$ mm.

Includes: Set screw.

Accessories: See page 188.

FINE BALANCED
G 2,5 at 25.000^{min}-1 or max.
residual imbalance ≤ 1 gmm

HSK-A 63

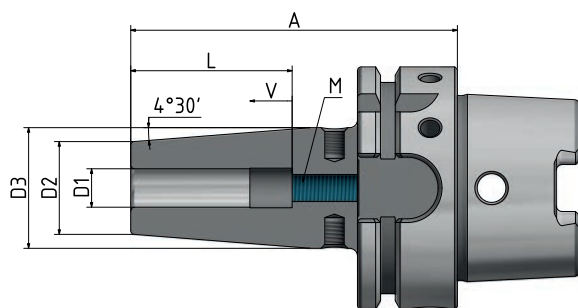

Fig. shows A = 130

Order No.	HSK	D1	A	D2	D3	L	V	M	Version
606321-13	63	3	80	12	17	-	-	-	Short
606321-14	63	4	80	12	17	-	-	-	Short
606321-15	63	5	80	12	17	-	-	-	Short
606321-01	63	6	80	21	27	37	10	M5	Short
606321-02	63	8	80	21	27	37	10	M6	Short
606321-03	63	10	85	24	32	42	10	M8x1	Short
606321-04	63	12	90	24	32	48	10	M10x1	Short
606321-05	63	14	90	27	34	48	10	M10x1	Short
606321-06	63	16	95	27	34	51	10	M12x1	Short
606321-07	63	18	95	33	42	51	10	M12x1	Short
606321-08	63	20	100	33	42	53	10	M16x1	Short
606321-09	63	25	115	44	53	59	10	M16x1	Short
606321-10	63	32	120	44	53	63	10	M16x1	Short

Shrink fit holder 4,5° (Continuation)

HSK-A 63

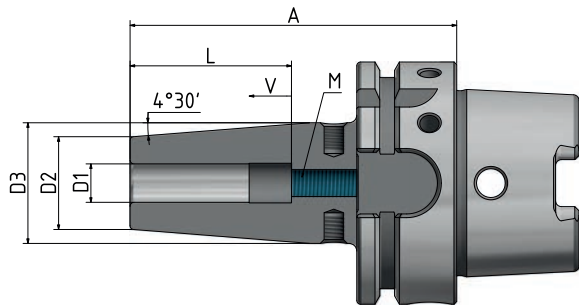

Fig. shows A = 130

Order No.	HSK	D1	A	D2	D3	L	V	M	Version
606321-313	63	3	120	12	17	-	-	-	Long
606321-314	63	4	120	12	17	-	-	-	Long
606321-315	63	5	120	12	17	-	-	-	Long
606321-31	63	6	120	21	27	37	10	M5	Long
606321-32	63	8	120	21	27	37	10	M6	Long
606321-33	63	10	120	24	32	42	10	M8x1	Long
606321-34	63	12	120	24	32	48	10	M10x1	Long
606321-35	63	14	120	27	34	48	10	M10x1	Long
606321-36	63	16	120	27	34	51	10	M12x1	Long
606321-37	63	18	120	33	42	51	10	M12x1	Long
606321-38	63	20	120	33	42	53	10	M16x1	Long
606321-39	63	25	120	44	53	59	10	M16x1	Long
606321-513	63	3	130	12	17	-	-	-	Long
606321-514	63	4	130	12	17	-	-	-	Long
606321-515	63	5	130	12	17	-	-	-	Long
606321-51	63	6	130	21	27	37	10	M5	Long
606321-52	63	8	130	21	27	37	10	M6	Long
606321-53	63	10	130	24	32	42	10	M8x1	Long
606321-54	63	12	130	24	32	48	10	M10x1	Long
606321-55	63	14	130	27	34	48	10	M10x1	Long
606321-56	63	16	130	27	34	51	10	M12x1	Long
606321-57	63	18	130	33	42	51	10	M12x1	Long
606321-58	63	20	130	33	42	53	10	M16x1	Long
606321-59	63	25	130	44	53	59	10	M16x1	Long
606321-60	63	32	130	44	53	63	10	M16x1	Long

HSK-A 63

Shrink fit holder 4,5° (Continuation)

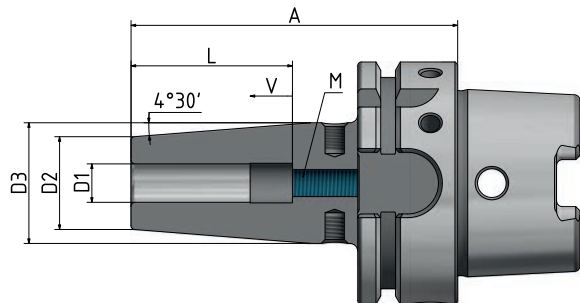

Fig. shows A = 130

HSK-A 63

Order No.	HSK	D1	A	D2	D3	L	V	M	Version
606321-613	63	3	160	12	17	-	-	-	Extra long
606321-614	63	4	160	12	17	-	-	-	Extra long
606321-615	63	5	160	12	17	-	-	-	Extra long
606321-61	63	6	160	21	27	37	10	M5	Extra long
606321-62	63	8	160	21	27	37	10	M6	Extra long
606321-63	63	10	160	24	32	42	10	M8x1	Extra long
606321-64	63	12	160	24	32	48	10	M10x1	Extra long
606321-65	63	14	160	27	34	48	10	M10x1	Extra long
606321-66	63	16	160	27	34	51	10	M12x1	Extra long
606321-67	63	18	160	33	42	51	10	M12x1	Extra long
606321-68	63	20	160	33	42	53	10	M16x1	Extra long
606321-69	63	25	160	44	53	59	10	M16x1	Extra long
606321-70	63	32	160	44	53	63	10	M16x1	Extra long
606321-81	63	6	200	21	27	37	10	M5	Extra long
606321-82	63	8	200	21	27	37	10	M6	Extra long
606321-83	63	10	200	24	32	42	10	M8x1	Extra long
606321-84	63	12	200	24	32	48	10	M10x1	Extra long
606321-85	63	14	200	27	34	48	10	M10x1	Extra long
606321-86	63	16	200	27	34	51	10	M12x1	Extra long
606321-87	63	18	200	33	42	51	10	M12x1	Extra long
606321-88	63	20	200	33	42	53	10	M16x1	Extra long
606321-89	63	25	200	44	53	59	10	M16x1	Extra long

Shrink fit holder 4,5° „Cool Tool“

Application: Particularly suitable for tools without internal coolant, and for machining at difficult positions with bad chip removal.

Technical Design: Made of special heat resistant steel. Suitable for inductive shrinking unit. With four additional threads for supplementary fine balancing. Runout of outer taper to $D1 \leq 0,003$ mm. With four additional threads for supplementary fine balancing. Two holes in the toolholder lead the coolant directly to the cutting edge.

Includes: Set screw and 2 x M3-screws to plug the coolant holes if needed.

Accessories: See page 188.

FINE BALANCED
G 2,5 at 25.000^{min-1} or max.
residual imbalance ≤ 1 gmm

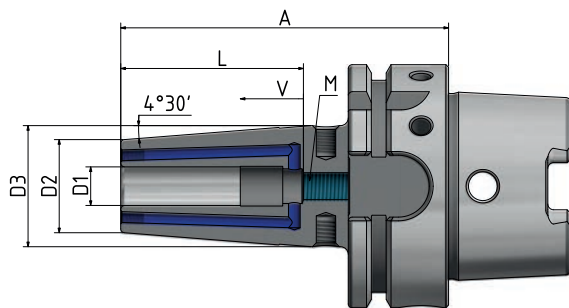

Fig. shows A = 130

Order No.	HSK	D1	A	D2	D3	L	V	M	Version
6063219-03**	63	10	70	26	33	42	-	-	Extra short
6063219-04**	63	12	70	26	33	45	-	-	Extra short
6063219-06**	63	16	75	29	37	50	-	-	Extra short
6063219-08**	63	20	75	35	43	50	-	-	Extra short
6063219-09**	63	25	85	45	50	59	-	-	Extra short
606321-139*	63	3	80	12	17	-	-	-	Short
606321-149*	63	4	80	12	17	-	-	-	Short
606321-159*	63	5	80	12	17	-	-	-	Short
606321-019	63	6	80	21	27	37	10	M5	Short
606321-029	63	8	80	21	27	37	10	M6	Short
606321-039	63	10	85	24	32	42	10	M8x1	Short
606321-049	63	12	90	24	32	48	10	M10x1	Short
606321-059	63	14	90	27	34	48	10	M10x1	Short
606321-069	63	16	95	27	34	51	10	M12x1	Short
606321-079	63	18	95	33	42	51	10	M12x1	Short
606321-089	63	20	100	33	42	53	10	M16x1	Short
606321-099	63	25	115	44	53	59	10	M16x1	Short

* Cool Tool holes cannot be plugged.

** Without additional balancing threads



HSK-A 63

Shrink fit holder 4,5° „Cool Tool“ (Continuation)

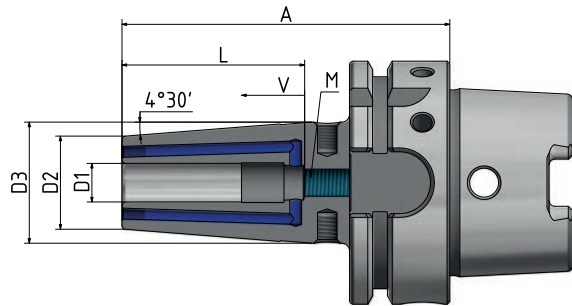

Fig. shows A = 130

HSK-A 63

Order No.	HSK	D1	A	D2	D3	L	V	M	Version
606321-319	63	6	120	21	27	37	10	M5	Long
606321-329	63	8	120	21	27	37	10	M6	Long
606321-339	63	10	120	24	32	42	10	M8x1	Long
606321-349	63	12	120	24	32	48	10	M10x1	Long
606321-359	63	14	120	27	34	48	10	M10x1	Long
606321-369	63	16	120	27	34	51	10	M12x1	Long
606321-379	63	18	120	33	42	51	10	M12x1	Long
606321-389	63	20	120	33	42	53	10	M16x1	Long
606321-5139*	63	3	130	12	17	-	-	-	Long
606321-5149*	63	4	130	12	17	-	-	-	Long
606321-5159*	63	5	130	12	17	-	-	-	Long
606321-519	63	6	130	21	27	37	10	M5	Long
606321-529	63	8	130	21	27	37	10	M6	Long
606321-539	63	10	130	24	32	42	10	M8x1	Long
606321-549	63	12	130	24	32	48	10	M10x1	Long
606321-559	63	14	130	27	34	48	10	M10x1	Long
606321-569	63	16	130	27	34	51	10	M12x1	Long
606321-579	63	18	130	33	42	51	10	M12x1	Long
606321-589	63	20	130	33	42	53	10	M16x1	Long
606321-599	63	25	130	44	53	59	10	M16x1	Long
606321-609	63	32	130	44	53	63	10	M16x1	Long
606321-619	63	6	160	21	27	37	10	M5	Extra long
606321-629	63	8	160	21	27	37	10	M6	Extra long
606321-639	63	10	160	24	32	42	10	M8x1	Extra long
606321-649	63	12	160	24	32	48	10	M10x1	Extra long
606321-669	63	16	160	27	34	51	10	M12x1	Extra long
606321-689	63	20	160	33	42	53	10	M16x1	Extra long

* Cool Tool holes cannot be plugged.



Shrink fit holder 4,5° – slim

Application: For clamping tools with cylindrical shank of solid carbide or HSS, tol. h6.

Technical Design: Made of special heat resistant steel. Suitable for inductive shrinking unit. Runout of outer taper to $D1 \leq 0,003$ mm.

Includes: Set screw.

Accessories: See page 188.

FINE BALANCED
G 2,5 at 25.000^{min}-1 or max.
residual imbalance ≤ 1 gmm

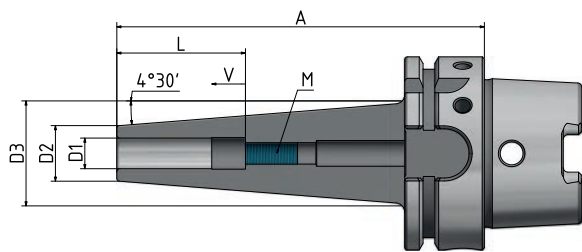

Order No.	HSK	D1	A	D2	D3	L	V	M	Version
606321-41*	63	6	120	15	30	37	10	M5	Long
606321-42*	63	8	120	15	30	37	10	M6	Long
606321-43*	63	10	120	18	33	42	10	M8x1	Long
606321-44*	63	12	120	18	33	48	10	M10x1	Long

* Without additional balancing threads

Version „Cool Tool“:

Order No.	HSK	D1	A	D2	D3	L	V	M	Version
6063219-41**	63	6	120	15	30	37	10	M5	Long
6063219-42**	63	8	120	16	31	37	10	M6	Long
6063219-43**	63	10	120	18	33	42	10	M8x1	Long
6063219-44**	63	12	120	20	35	48	10	M10x1	Long

* Cool Tool holes cannot be plugged.

** Without additional balancing threads



HSK-A 63

Shrink fit holder with 4 x „Cool Tool“ – Corrosion resistant

Application: Particularly suitable for tools without internal coolant, and for Machining at difficult positions with bad chip removal.

Technical Design: Made of special heat resistant steel. Suitable for inductive shrinking unit. With four additional threads for supplementary fine balancing. Runout of outer taper to D1 ≤ 0,003 mm. The entire front area of the tool holder is corrosion resistant. Four holes in the toolholder lead the coolant directly to the cutting edge.

Includes: Set screw and 4 x M3-screws to plug the coolant holes if needed.

Accessories: See page 188.

FINE BALANCED
G 2,5 at 25.000^{min}-1 or max.
residual imbalance ≤ 1 gmm

HSK-A 63

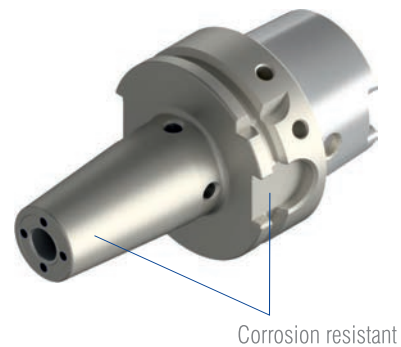
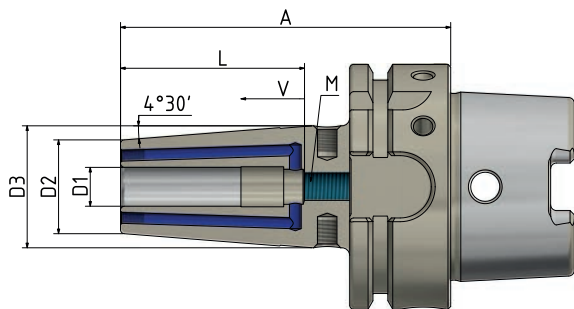

Order No.	HSK	D1	A	D2	D3	L	V	M	Version
606348-018	63	6	80	21	27	37	10	M5	Short
606348-028	63	8	80	21	27	37	10	M6	Short
606348-038	63	10	85	24	32	42	10	M8x1	Short
606348-048	63	12	90	24	32	48	10	M10x1	Short
606348-068	63	16	95	27	34	51	10	M12x1	Short
606348-088	63	20	100	33	42	53	10	M16x1	Short
606348-318	63	6	120	21	27	37	10	M5	Long
606348-328	63	8	120	21	27	37	10	M6	Long
606348-338	63	10	120	24	32	42	10	M8x1	Long
606348-348	63	12	120	24	32	48	10	M10x1	Long
606348-368	63	16	120	27	34	51	10	M12x1	Long
606348-388	63	20	120	33	42	53	10	M16x1	Long

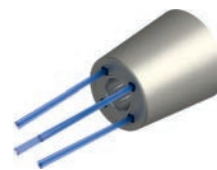

Shrink fit holder 3°

Application: For clamping tools with cylindrical shank of solid carbide or HSS, tol. h6.

Technical Design: Made of special heat resistant steel. Suitable for inductive shrinking unit. Runout of outer taper to $D1 \leq 0,003$ mm.

FINE BALANCED
G 2,5 at 25.000^{min}-1 or max.
residual imbalance ≤ 1 gmm

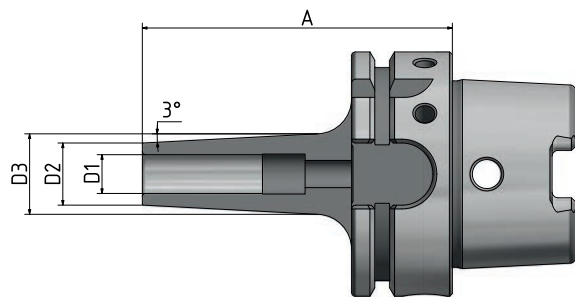

Fig. shows A = 120

Order No.	HSK	D1	A	D2	D3	Version
606351-13	63	3	80	9	14	Short
606351-14	63	4	80	10	15	Short
606351-15	63	5	80	11	16	Short
606351-01	63	6	80	12	18	Short
606351-02	63	8	80	14	20	Short
606351-03	63	10	80	16	22	Short
606351-04	63	12	80	18	24	Short
606351-313	63	3	120	9	18	Long
606351-314	63	4	120	10	19	Long
606351-315	63	5	120	11	20	Long
606351-31	63	6	120	12	22	Long
606351-32	63	8	120	14	24	Long
606351-33	63	10	120	16	26	Long
606351-34	63	12	120	18	28	Long

HSK-A 63

Thread shank adapter – Conical form

Application: For clamping threaded shank end mill bodies.

Technical Design: Runout of outer taper to $D1 \leq 0,005$ mm.

 **FINE BALANCED**
G 2,5 at 25.000^{min}-1 or max.
residual imbalance ≤ 1 gmm

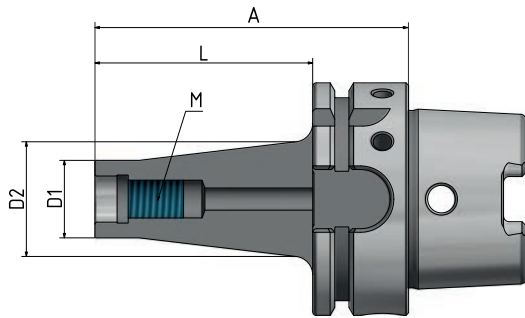

Order No.	HSK	M	A	L	D1	D2	Version
606308-01	63	M8	51	25	13	15	Conical
606308-02	63	M8	76	50	13	23	Conical
606308-03	63	M8	101	75	13	25	Conical
606308-04	63	M8	126	100	13	30	Conical
606310-01	63	M10	51	25	18	23	Conical
606310-02	63	M10	76	50	18	25	Conical
606310-03	63	M10	101	75	18	30	Conical
606310-04	63	M10	126	100	18	35	Conical
606310-06	63	M10	176	150	18	45	Conical
606312-01	63	M12	51	25	21	24	Conical
606312-02	63	M12	76	50	21	30	Conical
606312-03	63	M12	101	75	21	35	Conical
606312-04	63	M12	126	100	21	38	Conical
606312-06	63	M12	176	150	21	45	Conical
606316-01	63	M16	51	25	29	29	Conical
606316-02	63	M16	76	50	29	34	Conical
606316-03	63	M16	101	75	29	35	Conical
606316-04	63	M16	126	100	29	40	Conical
606316-06	63	M16	176	150	29	48	Conical

Thread shank adapter – Cylindrical form

Application: For clamping threaded shank end mill bodies.

Technical Design: Runout of outer taper to $D1 \leq 0,005$ mm.

FINE BALANCED
G 2,5 at 25.000^{min}-1 or max.
residual imbalance ≤ 1 gmm

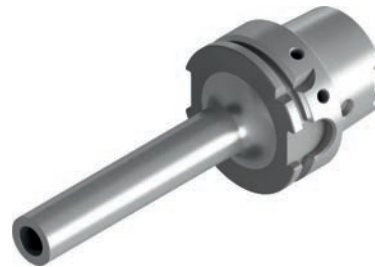
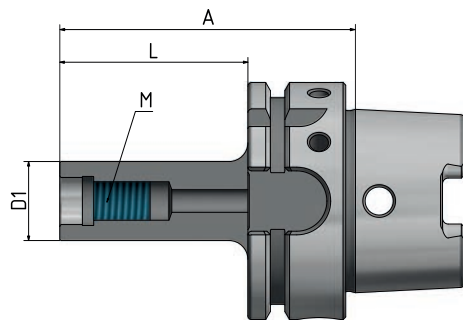

Order No.	HSK	M	A	L	D1	Version
6063067-01	63	M6	51	25	10	Cylindrical
6063087-01	63	M8	51	25	13	Cylindrical
6063087-02	63	M8	76	50	13	Cylindrical
6063087-03	63	M8	101	75	13	Cylindrical
6063087-04	63	M8	126	100	13	Cylindrical
6063107-01	63	M10	51	25	18	Cylindrical
6063107-02	63	M10	76	50	18	Cylindrical
6063107-03	63	M10	101	75	18	Cylindrical
6063107-04	63	M10	126	100	18	Cylindrical
6063107-05	63	M10	151	125	18	Cylindrical
6063107-06	63	M10	176	150	18	Cylindrical
6063127-01	63	M12	51	25	21	Cylindrical
6063127-02	63	M12	76	50	21	Cylindrical
6063127-03	63	M12	101	75	21	Cylindrical
6063127-04	63	M12	126	100	21	Cylindrical
6063127-05	63	M12	151	125	21	Cylindrical
6063127-06	63	M12	176	150	21	Cylindrical
6063167-01	63	M16	51	25	29	Cylindrical
6063167-02	63	M16	76	50	29	Cylindrical
6063167-03	63	M16	101	75	29	Cylindrical
6063167-04	63	M16	126	100	29	Cylindrical
6063167-06	63	M16	176	150	29	Cylindrical

HSK-A 63

Shell mill holder

- Application:** For adapting shell mills with transverse slot.
- Technical Design:** With extended flange.
Runout of outer taper to $D1 \leq 0,006$ mm.
- Includes:** Clamping screw and drive keys.
- Accessories:** See page 189.

 **FINE BALANCED**
G 2,5 at 25.000^{min}-1 or max.
residual imbalance ≤ 1 gmm

HSK-A 63

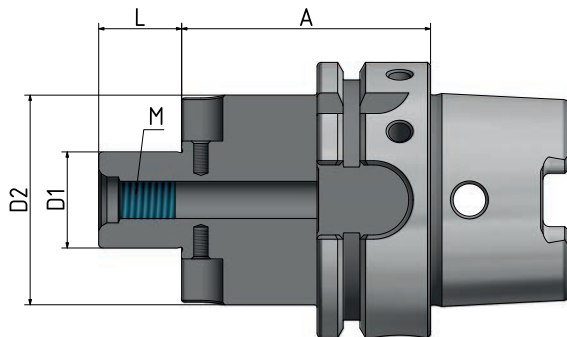

Fig. shows A = 160

Order No.	HSK	D1	A	D2	L	M	Version
606305-01	63	16	50	38	17	M8	Short
606305-02	63	22	50	48	19	M10	Short
606305-03	63	27	60	60	21	M12	Short
606305-04	63	32	60	78	24	M16	Short
606305-05	63	40	60	89	27	M20	Short
606305-011	63	16	100	38	17	M8	Long
606305-021	63	22	100	48	19	M10	Long
606305-031	63	27	100	60	21	M12	Long
606305-041	63	32	100	78	24	M16	Long
606305-051	63	40	100	89	27	M20	Long
606305-611	63	16	160	38	17	M8	Extra long
606305-621	63	22	160	48	19	M10	Extra long
606305-631	63	27	160	60	21	M12	Extra long
606305-641	63	32	160	78	24	M16	Extra long

Shell mill holder „Cool Tool“

- Application:** For adapting shell mills with transverse slot, with coolant mandrel on the cutting edge.
- Technical Design:** With extended flange. Runout of outer taper to D1 \leq 0,006 mm.
- Includes:** Clamping screw and drive keys.
- Accessories:** See page 189.

FINE BALANCED
G 2,5 at 25.000^{min}-1 or max.
residual imbalance \leq 1 gmm

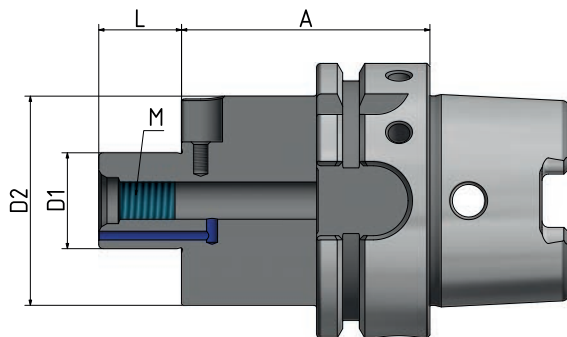

Fig. shows A = 130



Order No.	HSK	D1	A	D2	L	M	Version
606305-21	63	16	50	38	17	M8	Short
606305-22	63	22	50	48	19	M10	Short
606305-23	63	27	60	60	21	M12	Short
606305-24	63	32	60	78	24	M16	Short
606305-25	63	40	60	89	27	M20	Short
606305-319	63	16	75	38	17	M8	Short
606305-329	63	22	75	48	19	M10	Short
606305-339	63	27	80	60	21	M12	Short
606305-349	63	32	80	78	24	M16	Short
606305-359	63	40	80	89	27	M20	Short
606305-211	63	16	100	38	17	M8	Long
606305-221	63	22	100	48	19	M10	Long
606305-231	63	27	100	60	21	M12	Long
606305-241	63	32	100	78	24	M16	Long
606305-251	63	40	100	89	27	M20	Long
606305-519	63	16	130	38	17	M8	Long
606305-529	63	22	130	48	19	M10	Long
606305-539	63	27	130	60	21	M12	Long
606305-549	63	32	130	78	24	M16	Long
606305-559	63	40	130	89	27	M20	Long

Order No.	HSK	D1	A	D2	L	M	Version
606305-619	63	16	160	38	17	M8	Extra long
606305-629	63	22	160	48	19	M10	Extra long
606305-639	63	27	160	60	21	M12	Extra long
606305-649	63	32	160	78	24	M16	Extra long

HSK-A 63

Combi shell mill holder

- Application:** For adapting shell mills with transverse and longitudinal groove.
- Technical Design:** Runout of outer taper to $D1 \leq 0,006$ mm.
- Includes:** Clamping screw, drive key and adjusting spring.
- Accessories:** See page 190.

 **FINE BALANCED**
 G 2,5 at 25.000^{min}-1 or max.
 residual imbalance ≤ 1 gmm

HSK-A 63

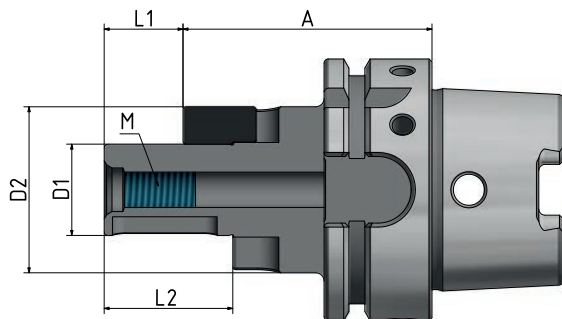

Fig. shows A = 160

Order No.	HSK	D1	A	D2	L1	L2	M	Version
606306-01	63	16	60	32	17	27	M8	Short
606306-02	63	22	60	40	19	31	M10	Short
606306-03	63	27	60	48	21	33	M12	Short
606306-04	63	32	60	58	24	38	M16	Short
606306-05	63	40	70	70	27	41	M20	Short
606306-011	63	16	100	32	17	27	M8	Long
606306-021	63	22	100	40	19	31	M10	Long
606306-031	63	27	100	48	21	33	M12	Long
606306-041	63	32	100	58	24	38	M16	Long
606306-61	63	16	160	32	17	27	M8	Extra long
606306-62	63	22	160	40	19	31	M10	Extra long
606306-63	63	27	160	48	21	33	M12	Extra long
606306-64	63	32	160	58	24	38	M16	Extra long
606306-65	63	40	160	70	27	41	M20	Extra long

Morse taper adapter according to DIN 228A

Application For holding morse taper tools with tang according to DIN 228A.

Technical Design: Runout of outer taper to $D1 \leq 0,008$ mm.

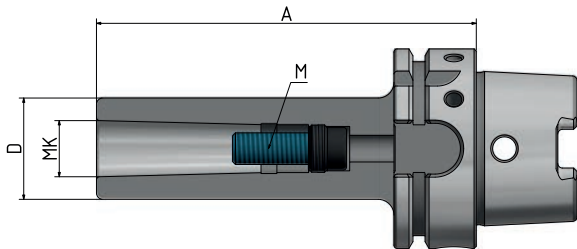

Order No.	HSK	MK	M	A	D	Version
606314-01	63	1	M6	100	25	Short
606314-02	63	2	M10	120	32	Short
606314-03	63	3	M12	140	40	Short
606314-04	63	4	M16	160	48	Short

Morse taper adapter according to DIN 228B

Application: For holding morse taper tools with tang according to DIN 228B.

Technical Design: Runout of outer taper to $D1 \leq 0,008$ mm.

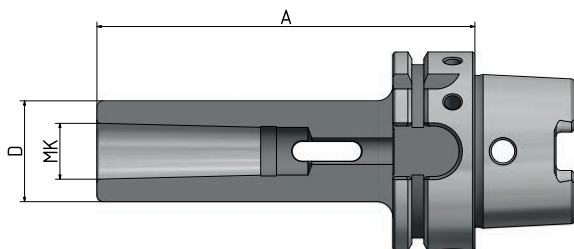

Order No.	HSK	MK	A	D	Version
606313-01	63	1	100	25	Short
606313-02	63	2	120	32	Short
606313-03	63	3	140	40	Short
606313-04	63	4	160	48	Short

HSK-A 63

Short drill chuck

Application: For clamping tools with cylindrical shank.
Also suitable for tools with internal coolant.

Includes: Wrench

BALANCED
G 6,3 at 8.000^{min-1}

HSK-A 63

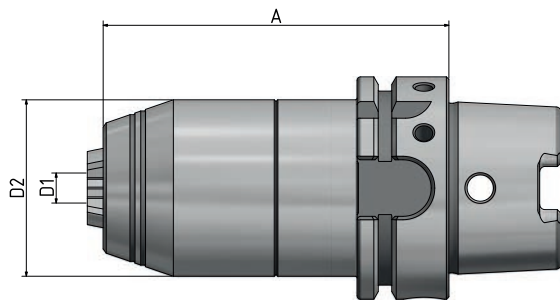

Order No.	HSK	Clamping range D1	A	D2
606395-52	63	1-16	98	50

HPC – Precision ER collet chuck HAWK EYE®

Application: For clamping tools with cylindrical shank in collets ER.

Technical Design: Due to high precision taper tolerances of the ER-Inner taper and the collet taper max. runout of $\leq 5 \mu$ at $2,5 \times D$, subject the usage of our HP 2μ ER collets. The deep fit of the collet inside the chuck combined with a surface treated clamping nut achieves more than double clamping force compared to standard ER collet chuck. HAWK EYE® has an enforced body for max. radial rigidity. The patented special design of HAWK EYE® chuck is only suitable to clamp nominal diameters of the collet used.

Includes: Special clamping nut.

Accessories: See page 183.

FINE BALANCED
G 2,5 at 25.000^{min-1} or max.
residual imbalance ≤ 1 gmm

HSK-A 80

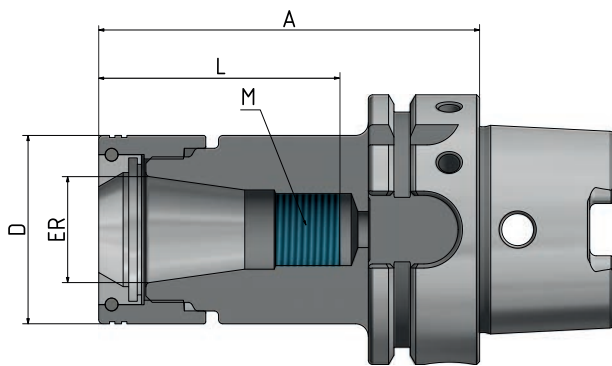

Fig. shows A = 130

Order No.	HSK	ER	D	A	Clamping range	L	M	Version
608032-002	80	16	34	75	1–10	32	-	Extra short
608032-004	80	25	44	75	1–16	39	-	Extra short
608032-005	80	32	52	75	2–20	46	-	Extra short
608032-006	80	40	62	85	4–26	52	-	Extra short
608032-02	80	16	34	100	1–10	58	M11x1	Short
608032-04	80	25	44	100	1–16	68	M18x1,5	Short
608032-05	80	32	52	100	2–20	72	M24x1,5	Short
608032-06	80	40	62	100	4–26	76	M28x1,5	Short
608032-52	80	16	34	130	1–10	58	M11x1	Long
608032-54	80	25	44	130	1–16	68	M18x1,5	Long
608032-55	80	32	52	130	2–20	78	M24x1,5	Long
608032-56	80	40	62	130	4–26	86	M28x1,5	Long



Sealed versions
see pages 186, 187.

HSK-A 80

HPC – Precision ER collet chuck HAWK EYE® „Mini“

Application: For clamping tools with cylindrical shank in collets ER.

Technical Design: Due to high precision taper tolerances of the ER-Inner taper and the collet taper max. runout of $\leq 5 \mu$ at $2,5 \times D$, subject the usage of our HP 2μ ER collets. The deep fit of the collet inside the chuck combined with a surface treated clamping nut achieves more than double clamping force compared to standard ER collet chuck. HAWK EYE® has an enforced body for max. radial rigidity. The patented special design of HAWK EYE® chuck is only suitable to clamp nominal diameters of the collet used.

Includes: Special clamping nut.

Accessories: See page 183.

FINE BALANCED
G 2,5 at 25.000^{min}-1 or max.
residual imbalance ≤ 1 gmm

HSK-A 80

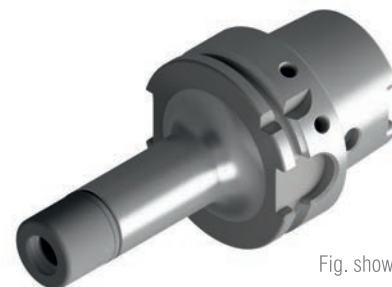
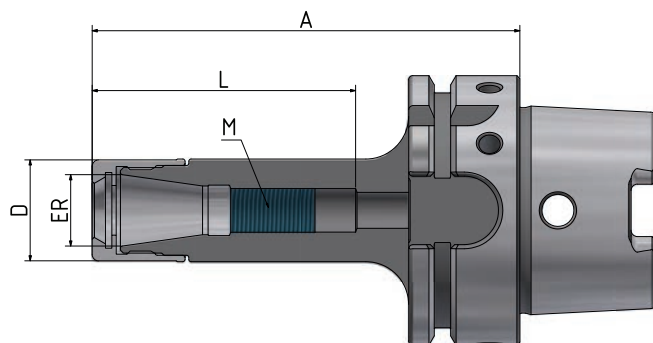

Fig. shows A = 100

Order No.	HSK	ER	D	A	Clamping range	L	M	Version
608034-01	80	11	16	100	1–7	48	M8x1	Short
608034-02	80	16	24	100	1–10	61	M11x1	Short



Sealed versions
see pages 186, 187.

ER-Collet chuck

Application: For clamping tools with cylindrical shank in collets ER.

Technical Design: Runout of outer taper to inner taper $\leq 0,003$ mm.
Due to adjusted taper tolerances of the ER-Inner taper and the collet taper max. runout of $\leq 8 \mu$ at $2,5 \times D$.

Includes: Clamping nut.

Accessories: See page 183.

FINE BALANCED
G 2,5 at 25.000^{min-1} or max.
residual imbalance ≤ 1 gmm

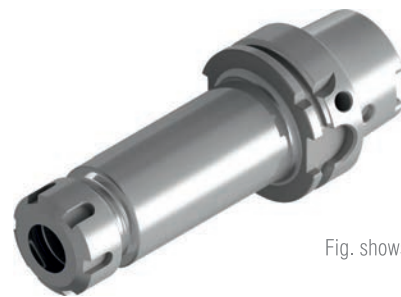
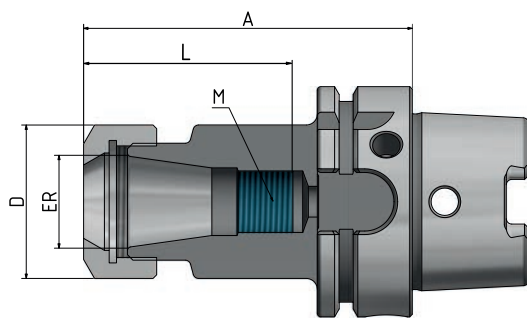

Fig. shows A = 160

Order No.	HSK	ER	D	A	Clamping range	L	M	Version
608002-01	80	16	28	100	1-10	58	M11x1	Short
608002-02	80	25	42	100	1-16	68	M18x1,5	Short
608002-03	80	32	50	100	2-20	70	M24x1,5	Short
608002-04	80	40	63	120	4-26	90	M28x1,5	Short
608002-011	80	16	28	160	1-10	58	M11x1	Extra long
608002-021	80	25	42	160	1-16	75	M18x1,5	Extra long
608002-031	80	32	50	160	2-20	82	M24x1,5	Extra long



Sealed versions
see pages 186, 187.

HSK-A 80

Endmill holder Weldon

- Application:** For clamping tools with cylindrical shank according to DIN 1835B/6359HB.
- Technical Design:** Runout of outer taper to $D1 \leq 0,003$ mm. Tolerance of bore H4 (more accurate as DIN).
- Includes:** Clamping screw, from $\varnothing 25$ with 2 clamping screws.
- Accessories:** See page 188.

 **FINE BALANCED**
G 2,5 at 25.000^{min}-1 or max.
residual imbalance ≤ 1 gmm

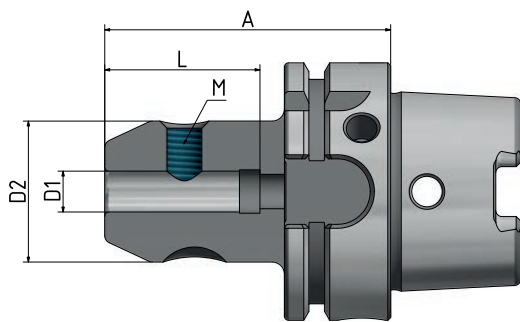

Fig. shows $\varnothing 25$ with 2 clamping screws

Order No.	HSK	D1	A	D2	L	M	Version
608004-01	80	6	80	25	35	M6	Short
608004-02	80	8	80	28	35	M8	Short
608004-03	80	10	80	35	41	M10	Short
608004-04	80	12	80	42	48	M12	Short
608004-06	80	16	100	48	51	M14	Short
608004-08	80	20	100	52	53	M16	Short
608004-09	80	25	100	65	60	M18x2	Short
608004-10	80	32	110	72	64	M20x2	Short

Shrink fit holder 4,5°

Application: For clamping tools with cylindrical shank of solid carbide or HSS, tol. h6.

Technical Design: Made of special heat resistant steel. Suitable for inductive shrinking unit. With four additional threads for supplementary fine balancing. Runout of outer taper to $D1 \leq 0,003$ mm.

Includes: Set screw.

Accessories: See page 188.

FINE BALANCED
G 2,5 at 25.000^{min}-1 or max.
residual imbalance ≤ 1 gmm

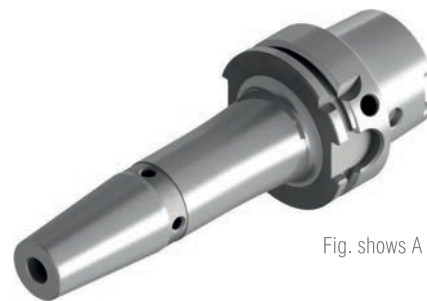
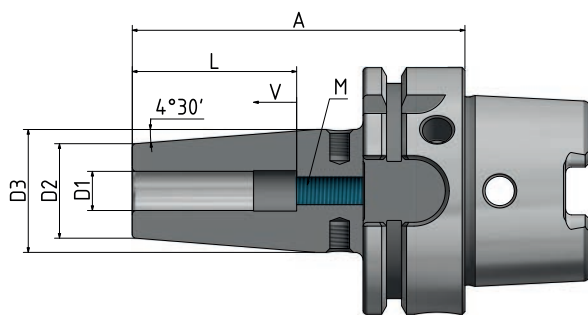

Fig. shows A = 160

Order No.	HSK	D1	A	D2	D3	L	V	M	Version
608021-01	80	6	85	21	27	37	10	M5	Short
608021-02	80	8	85	21	27	37	10	M6	Short
608021-03	80	10	90	24	32	42	10	M8x1	Short
608021-04	80	12	95	24	32	48	10	M10x1	Short
608021-05	80	14	95	27	34	48	10	M10x1	Short
608021-06	80	16	100	27	34	51	10	M12x1	Short
608021-07	80	18	100	33	42	51	10	M12x1	Short
608021-08	80	20	105	33	42	53	10	M16x1	Short
608021-09	80	25	115	44	53	59	10	M16x1	Short
608021-10	80	32	120	44	53	63	10	M16x1	Short
608021-61	80	6	160	21	27	37	10	M5	Extra long
608021-62	80	8	160	21	27	37	10	M6	Extra long
608021-63	80	10	160	24	32	42	10	M8x1	Extra long
608021-64	80	12	160	24	32	48	10	M10x1	Extra long
608021-66	80	16	160	27	34	51	10	M12x1	Extra long
608021-68	80	20	160	33	42	53	10	M16x1	Extra long
608021-69	80	25	160	44	53	59	10	M16x1	Extra long

HSK-A 80

Shell mill holder „Cool Tool“

Application: For adapting shell mills with transverse slot, with coolant mandrel on the cutting edge.

Technical Design: With extended flange.
Runout of outer taper to $D1 \leq 0,006$ mm.

Includes: Clamping screw and drive keys.

Accessories: See page 189.

FINE BALANCED
G 2,5 at 25.000^{min}-1 or max.
residual imbalance ≤ 1 gmm

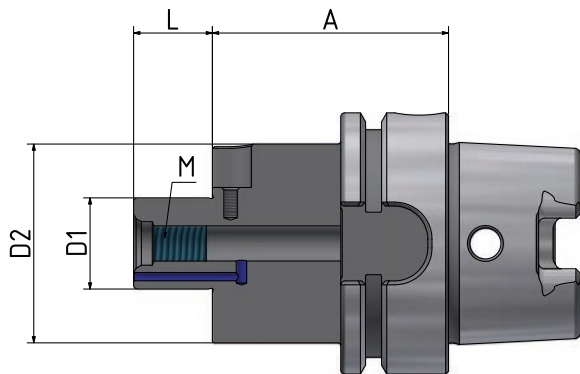

Fig. shows A = 60

Order No.	HSK	D1	A	D2	L1	M	Version
608005-22	80	22	50	48	19	M8	Short
608005-23	80	27	50	60	21	M10	Short
608005-24	80	32	60	78	24	M12	Short
608005-25	80	40	60	89	27	M16	Short



HPC – Precision ER collet chuck HAWK EYE®

Application: For clamping tools with cylindrical shank in collets ER.

Technical Design: Due to high precision taper tolerances of the ER-Inner taper and the collet taper max. runout of $\leq 5 \mu$ at $2,5 \times D$, subject the usage of our HP 2μ ER collets. The deep fit of the collet inside the chuck combined with a surface treated clamping nut achieves more than double clamping force compared to standard ER collet chuck. HAWK EYE® has an enforced body for max. radial rigidity. The patented special design of HAWK EYE® chuck is only suitable to clamp nominal diameters of the collet used.

Includes: Special clamping nut.

Accessories: See page 183.

FINE BALANCED
G 2,5 at 25.000^{min-1} or max.
residual imbalance ≤ 1 gmm

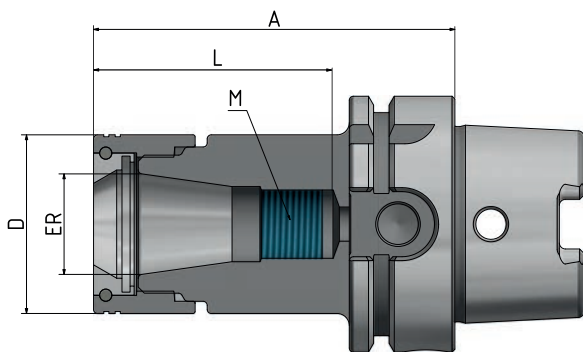

Fig. shows A = 130

Order No.	HSK	ER	D	Clamping range			M	Version
				A	L			
610032-002	100	16	34	75	1-10	32	-	Extra short
610032-004	100	25	44	75	1-16	39	-	Extra short
610032-005	100	32	52	75	2-20	45	-	Extra short
610032-006	100	40	62	85	4-26	53	-	Extra short
610032-02	100	16	34	100	1-10	71	M11x1	Short
610032-04	100	25	44	100	1-16	68	M18x1,5	Short
610032-05	100	32	52	100	2-20	69	M24x1,5	Short
610032-06	100	40	62	100	4-26	69	M28x1,5	Short
610032-52	100	16	34	130	1-10	101	M11x1	Long
610032-54	100	25	44	130	1-16	69	M18x1,5	Long
610032-55	100	32	52	130	2-20	78	M24x1,5	Long
610032-56	100	40	62	130	4-26	92	M28x1,5	Long
610032-62	100	16	34	160	1-10	131	M11x1	Extra long
610032-64	100	25	44	160	1-16	69	M18x1,5	Extra long
610032-65	100	32	52	160	2-20	78	M24x1,5	Extra long
610032-66	100	40	62	160	4-26	92	M28x1,5	Extra long



Sealed versions
see pages 186, 187.

HSK-A 100

ER-Collet chuck

Application: For clamping tools with cylindrical shank in collets ER.

Technical Design: Runout of outer taper to inner taper $\leq 0,003$ mm.
Due to adjusted taper tolerances of the ER-Inner taper and the collet taper max. runout of $\leq 8 \mu$ at $2,5 \times D$.

Includes: Clamping nut.

Accessories: See page 183.

FINE BALANCED
G 2,5 at 25.000^{min-1} or max.
residual imbalance ≤ 1 gmm

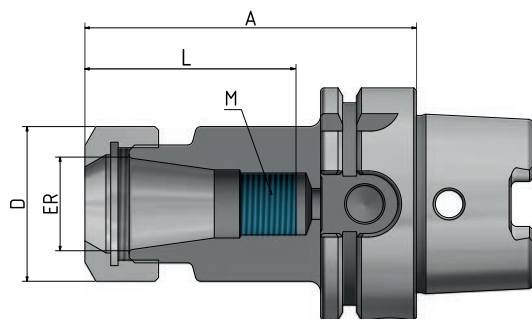

Fig. shows A = 130

HSK-A 100

Order No.	HSK	ER	D	Clamping range			M	Version
				A	L			
610002-01	100	16	28	100	1-10	71	M11x1	Short
610002-07	100	20	34	100	1-13	66	M14x1	Short
610002-02	100	25	42	100	1-16	67	M18x1,5	Short
610002-03	100	32	50	100	2-20	68	M24x1,5	Short
610002-04	100	40	63	120	4-26	88	M28x1,5	Short
610002-51	100	16	28	130	1-10	101	M11x1	Long
610002-57	100	20	34	130	1-13	71	M14x1	Long
610002-52	100	25	42	130	1-16	75	M18x1,5	Long
610002-53	100	32	50	130	2-20	82	M24x1,5	Long
610002-54	100	40	63	130	4-26	93	M28x1,5	Long
610002-011	100	16	28	160	1-10	131	M11x1	Extra long
610002-071	100	20	34	160	1-13	71	M14x1	Extra long
610002-021	100	25	42	160	1-16	75	M18x1,5	Extra long
610002-031	100	32	50	160	2-20	82	M24x1,5	Extra long
610002-041	100	40	63	160	4-26	96	M28x1,5	Extra long
610002-12	100	16	28	200	1-10	171	M11x1	Extra long
610002-22	100	25	42	200	1-16	75	M18x1,5	Extra long
610002-32	100	32	50	200	2-20	82	M24x1,5	Extra long
610002-42	100	40	63	200	4-26	96	M28x1,5	Extra long



Sealed versions
see pages 186, 187.

ER-Collet chuck „Mini“

Application: For clamping tools with cylindrical shank in collets ER.

Technical Design: Runout of outer taper to inner taper $\leq 0,003$ mm.
Due to adjusted taper tolerances of the ER-Inner taper and the collet taper max. runout of $\leq 8 \mu$ at $2,5 \times D$.

Includes: Clamping nut.

Accessories: See page 183.

FINE BALANCED
G 2,5 at 25.000^{min-1} or max.
residual imbalance ≤ 1 gmm

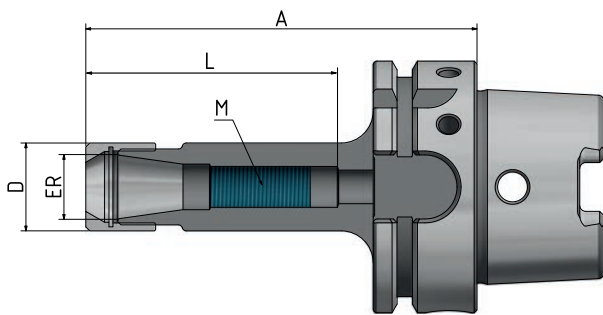

Fig. shows A = 160

Order No.	HSK	ER	D	A	Clamping range	L	M	Version
610002-21	100	11	16	100	1-7	49	M8x1	Short
610002-23	100	16	22	100	1-10	71	M11x1,5	Short
610002-27	100	25	35	100	1-16	67	M18x1,5	Short
610002-29	100	11	16	160	1-7	49	M8x1	Extra long
610002-24	100	16	22	160	1-10	131	M11x1	Extra long
610002-28	100	25	35	160	1-16	75	M18x1,5	Extra long



Sealed versions
see pages 186, 187.

HSK-A 100

ER-Collet chuck – Corrosion resistant

Application: For clamping tools with cylindrical shank in collets ER.

Technical Design: The entire front area of the tool holder is corrosion resistant.
Runout of outer taper to inner taper $\leq 0,003$ mm.
Due to adjusted taper tolerances of the ER-Inner taper and the collet taper max. runout of $\leq 8\mu$ at $2,5 \times D$.

Includes: Clamping nut.

Accessories: See page 183.

FINE BALANCED
G 2,5 at 25.000^{min-1} or max.
residual imbalance ≤ 1 gmm

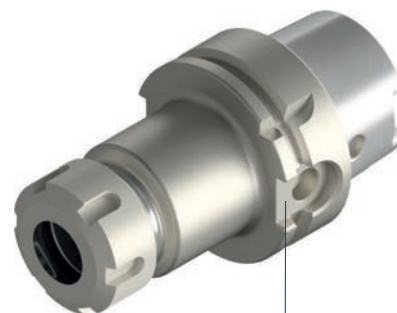
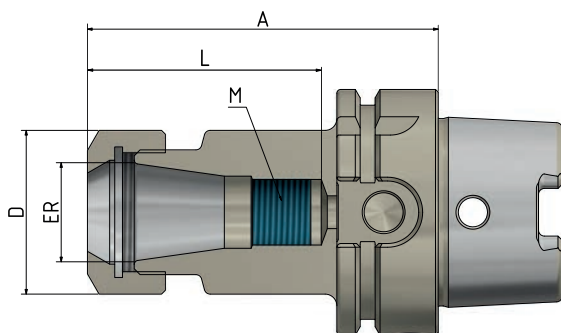

Corrosion resistant

Order No.	HSK	ER	D	A	Clamping range	L	M	Version
6100028-01	100	16	28	100	1-10	71	M11x1	Short
6100028-02	100	25	42	100	1-16	67	M18x1,5	Short
6100028-03	100	32	50	100	2-20	68	M24x1,5	Short
6100028-04	100	40	63	120	4-26	88	M28x1,5	Short



Sealed versions
see pages 186, 187.

Endmill holder Weldon

- Application:** For clamping tools with cylindrical shank according to DIN 1835B/6359HB.
- Technical Design:** Runout of outer taper to $D1 \leq 0,003$ mm. Tolerance of bore H4 (more accurate as DIN).
- Includes:** Clamping screw, from $\emptyset 25$ with 2 clamping screws.
- Accessories:** See page 188.

FINE BALANCED
G 2,5 at 25.000^{min}-1 or max.
residual imbalance ≤ 1 gmm

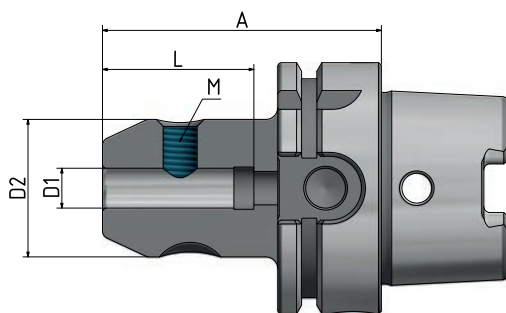

Fig. shows A = 160



Fig. shows $\emptyset 25$ with 2 clamping screws

Order No.	HSK	D1	A	D2	L	M	Version
610004-01	100	6	80	25	35	M6	Short
610004-02	100	8	80	28	35	M8	Short
610004-03	100	10	80	35	41	M10	Short
610004-04	100	12	80	42	48	M12	Short
610004-05	100	14	80	44	48	M12	Short
610004-06	100	16	100	48	51	M14	Short
610004-07	100	18	100	50	51	M14	Short
610004-08	100	20	100	52	53	M16	Short
610004-10	100	25	100	65	60	M18x2	Short
610004-11	100	32	100	72	64	M20x2	Short
610004-12	100	40	120	80	74	M20x2	Short
610004-61	100	6	160	25	35	M6	Extra long
610004-62	100	8	160	28	35	M8	Extra long
610004-63	100	10	160	35	41	M10	Extra long
610004-64	100	12	160	42	48	M12	Extra long
610004-65	100	14	160	44	48	M12	Extra long
610004-66	100	16	160	48	51	M14	Extra long
610004-67	100	18	160	50	51	M14	Extra long
610004-68	100	20	160	52	53	M16	Extra long
610004-69	100	25	160	65	60	M18x2	Extra long
610004-70	100	32	160	72	64	M20x2	Extra long

HSK-A 100

Endmill holder Weldon „Cool Tool“

- Application:** Particularly suitable for tools without internal coolant, and for machining at difficult positions with bad chip removal.
- Technical Design:** Two holes in the toolholder lead the coolant directly to the cutting edge. Runout of outer taper to $D1 \leq 0,003$ mm. Tolerance of bore H4 (more accurate as DIN).
- Includes:** Clamping screw (from $\varnothing 25$ with 2 clamping screws) and 2 x M3-screws to plug the coolant holes if needed.
- Accessories:** See page 188.

FINE BALANCED
G 2,5 at 25.000^{min}-1 or max.
residual imbalance ≤ 1 gmm

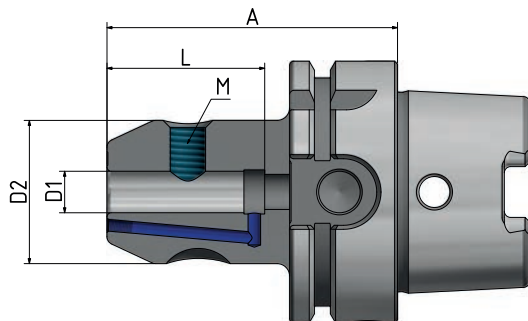

Fig. shows A = 160

Order No.	HSK	D1	A	D2	L	M	Version
6100041-01	100	6	80	25	35	M6	Short
6100041-02	100	8	80	28	35	M8	Short
6100041-03	100	10	80	35	41	M10	Short
6100041-04	100	12	80	42	48	M12	Short
6100041-05	100	14	80	44	48	M12	Short
6100041-06	100	16	100	48	51	M14	Short
6100041-07	100	18	100	50	51	M14	Short
6100041-08	100	20	100	52	53	M16	Short
6100041-09	100	25	100	65	60	M18x2	Short
6100041-10	100	32	100	72	64	M20x2	Short
6100041-61	100	6	160	25	35	M6	Extra long
6100041-62	100	8	160	28	35	M8	Extra long
6100041-63	100	10	160	35	41	M10	Extra long
6100041-64	100	12	160	42	48	M12	Extra long
6100041-65	100	14	160	44	48	M12	Extra long
6100041-66	100	16	160	48	51	M14	Extra long
6100041-67	100	18	160	50	51	M14	Extra long
6100041-68	100	20	160	52	53	M16	Extra long



Fig. shows $\varnothing 25$ with 2 clamping screws



Endmill holder Weldon with 4 x „Cool Tool“ – Corrosion resistant

Application: Particularly suitable for tools without internal coolant, and for machining at difficult positions with bad chip removal.

Technical Design: The entire front area of the tool holder is corrosion resistant.
Runout of outer taper to inner taper $\leq 0,003$ mm.
Tolerance of bore H4 (more accurate as DIN).
Four holes in the toolholder lead the coolant directly to the cutting edge.

Includes: Clamping screw and 4 x M3-screws to plug the coolant holes if needed.

Accessories: See page 188.

FINE BALANCED
G 2,5 at 25.000^{min}-1 or max.
residual imbalance ≤ 1 gmm

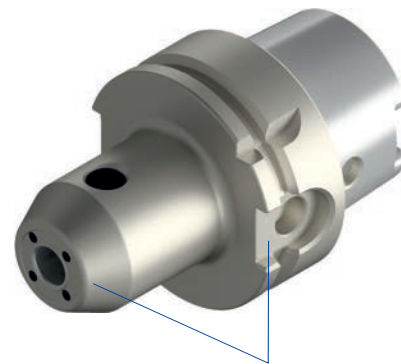
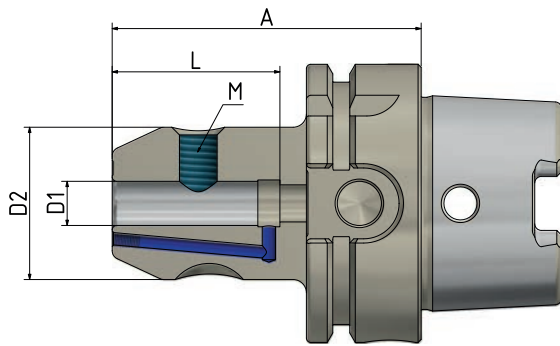

Corrosion resistant

Order No.	HSK	D1	A	D2	L	M	Version
6100048-018	100	6	80	25	35	M6	Short
6100048-028	100	8	80	28	35	M8	Short
6100048-038	100	10	80	35	41	M10	Short
6100048-048	100	12	80	42	48	M12	Short
6100048-068	100	16	100	48	51	M14	Short
6100048-088	100	20	100	52	53	M16	Short



4-fold Cool Tool

HSK-A 100

Endmill holder Whistle-Notch

Application: For clamping tools with cylindrical shank according to DIN 1835E/6359HE.

Technical Design: Runout of outer taper to $D1 \leq 0,003$ mm.
Tolerance of bore H4 (more accurate as DIN).

Includes: Clamping screw (from $\varnothing 25$ with 2 clamping screws) and set screw.

Accessories: See page 188.

 **BALANCED**
G 6,3 at 8.000^{min-1}

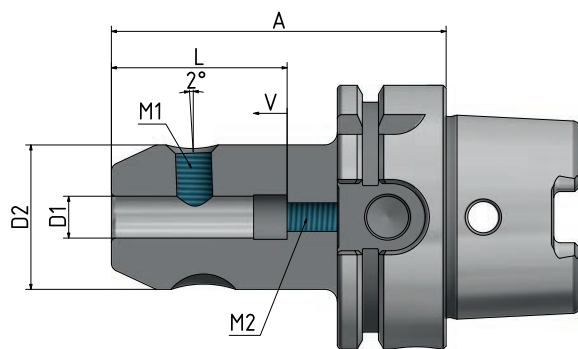

HSK-A 100

Order No.	HSK	D1	A	D2	L	M1	M2	Version
610009-01	100	6	90	25	36,5	M6	M5	Short
610009-02	100	8	90	28	36,5	M8	M6	Short
610009-03	100	10	90	35	40,5	M10	M8	Short
610009-04	100	12	100	42	45,5	M12	M10	Short
610009-05	100	14	100	44	45,5	M12	M10	Short
610009-06	100	16	100	48	48,5	M14	M12	Short
610009-07	100	18	100	50	48,5	M14	M12	Short
610009-08	100	20	110	52	50,5	M16	M16	Short
610009-10	100	25	120	65	56,5	M18x2	M20	Short
610009-11	100	32	120	72	60,5	M20x2	M20	Short



Fig. shows $\varnothing 25$ with 2 clamping screws

Shrink fit holder 4,5°

Application: For clamping tools with cylindrical shank of solid carbide or HSS, tol. h6.

Technical Design: Made of special heat resistant steel. Suitable for inductive shrinking unit. With four additional threads for supplementary fine balancing. Runout of outer taper to $D1 \leq 0,003$ mm.

Includes: Set screw.

Accessories: See page 188.

FINE BALANCED
G 2,5 at 25.000^{min}-1 or max.
residual imbalance ≤ 1 gmm

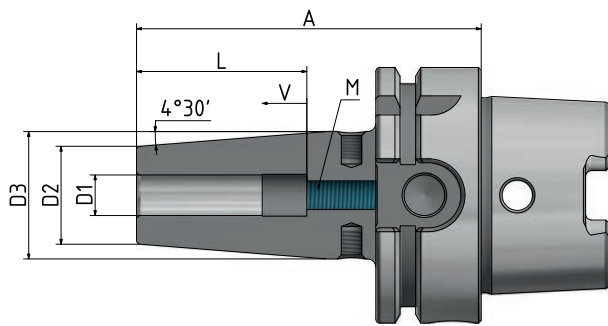

Fig. shows A = 120

Order No.	HSK	D1	A	D2	D3	L	V	M	Version
610021-01	100	6	85	21	27	37	10	M5	Short
610021-02	100	8	85	21	27	37	10	M6	Short
610021-03	100	10	90	24	32	42	10	M8x1	Short
610021-04	100	12	95	24	32	48	10	M10x1	Short
610021-05	100	14	95	27	34	48	10	M10x1	Short
610021-06	100	16	100	27	34	51	10	M12x1	Short
610021-07	100	18	100	33	42	51	10	M12x1	Short
610021-08	100	20	105	33	42	53	10	M16x1	Short
610021-09	100	25	115	44	53	59	10	M16x1	Short
610021-10	100	32	120	44	53	63	10	M16x1	Short
610021-31	100	6	120	21	27	37	10	M5	Long
610021-32	100	8	120	21	27	37	10	M6	Long
610021-33	100	10	120	24	32	42	10	M8x1	Long
610021-34	100	12	120	24	32	48	10	M10x1	Long
610021-35	100	14	120	27	34	48	10	M10x1	Long
610021-36	100	16	120	27	34	51	10	M12x1	Long
610021-37	100	18	120	33	42	51	10	M12x1	Long
610021-38	100	20	120	33	42	53	10	M16x1	Long

HSK-A 100

Shrink fit holder 4,5° (Continuation)

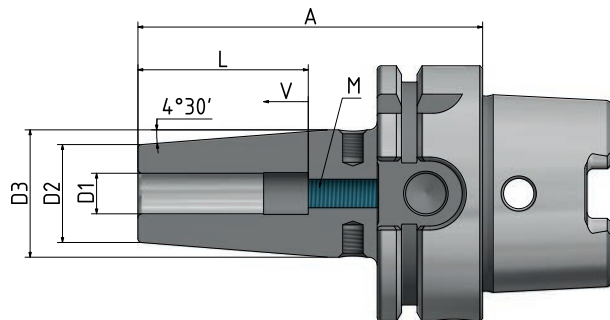

Fig. shows A = 130

Order No.	HSK	D1	A	D2	D3	L	V	M	Version
610021-51	100	6	130	21	27	37	10	M5	Long
610021-52	100	8	130	21	27	37	10	M6	Long
610021-53	100	10	130	24	32	42	10	M8x1	Long
610021-54	100	12	130	24	32	48	10	M10x1	Long
610021-55	100	14	130	27	34	48	10	M10x1	Long
610021-56	100	16	130	27	34	51	10	M12x1	Long
610021-57	100	18	130	33	42	51	10	M12x1	Long
610021-58	100	20	130	33	42	53	10	M16x1	Long
610021-59	100	25	130	44	53	59	10	M16x1	Long
610021-60	100	32	130	44	53	63	10	M16x1	Long
610021-61	100	6	160	21	27	37	10	M5	Extra long
610021-62	100	8	160	21	27	37	10	M6	Extra long
610021-63	100	10	160	24	32	42	10	M8x1	Extra long
610021-64	100	12	160	24	32	48	10	M10x1	Extra long
610021-65	100	14	160	27	34	48	10	M10x1	Extra long
610021-66	100	16	160	27	34	51	10	M12x1	Extra long
610021-67	100	18	160	33	42	51	10	M12x1	Extra long
610021-68	100	20	160	33	42	53	10	M16x1	Extra long
610021-69	100	25	160	44	53	59	10	M16x1	Extra long
610021-70	100	32	160	44	53	63	10	M16x1	Extra long
610021-81	100	6	200	21	27	37	10	M5	Extra long
610021-82	100	8	200	21	27	37	10	M6	Extra long
610021-83	100	10	200	24	32	42	10	M8x1	Extra long
610021-84	100	12	200	24	32	48	10	M10x1	Extra long
610021-85	100	14	200	27	34	48	10	M10x1	Extra long
610021-86	100	16	200	27	34	51	10	M12x1	Extra long
610021-87	100	18	200	33	42	51	10	M12x1	Extra long
610021-88	100	20	200	33	42	53	10	M16x1	Extra long
610021-89	100	25	200	44	53	59	10	M16x1	Extra long
610021-90	100	32	200	44	53	63	10	M16x1	Extra long

Shrink fit holder 4,5° slim

Application: For clamping tools with cylindrical shank of solid carbide or HSS, tol. h6.

Technical Design: Made of special heat resistant steel. Suitable for inductive shrinking unit. Runout of outer taper to $D1 \leq 0,003$ mm.

Includes: Set screw.

Accessories: See page 188.

FINE BALANCED
G 2,5 at 25.000^{min}-1 or max.
residual imbalance ≤ 1 gmm

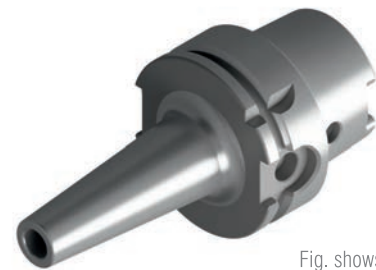
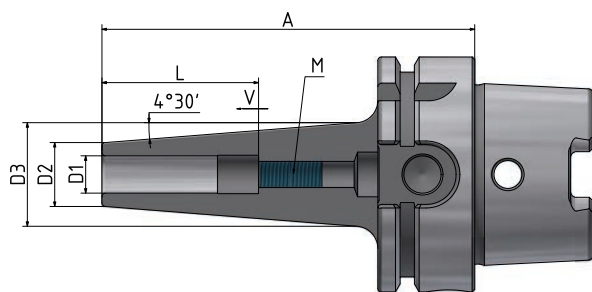

Fig. shows A = 120

Order No.	HSK	D1	A	D2	D3	L	V	M	Version
610053-31	100	6	120	15	30	37	10	M5	Long
610053-32	100	8	120	15	30	37	10	M6	Long
610053-33	100	10	120	18	33	42	10	M8x1	Long
610053-34	100	12	120	18	33	48	10	M10x1	Long

HSK-A 100

Shrink fit holder 4,5° „Cool Tool“

Application: Particularly suitable for tools without internal coolant, and for machining at difficult positions with bad chip removal.

Technical Design: Made of special heat resistant steel. Suitable for inductive shrinking unit. With four additional threads for supplementary fine balancing. Runout of outer taper to $D1 \leq 0,003$ mm. With four additional threads for supplementary fine balancing. Two holes in the toolholder lead the coolant directly to the cutting edge.

Includes: Set screw and 2 x M3-screws to plug the coolant holes if needed.

Accessories: See page 188.

 **FINE BALANCED**
G 2,5 at 25.000^{min}-1 or max.
residual imbalance ≤ 1 gmm

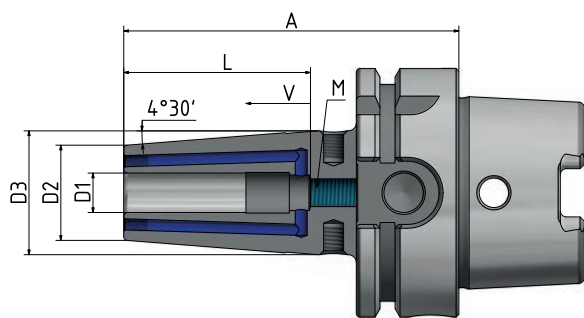

Order No.	HSK	D1	A	D2	D3	L	V	M	Version
610021-019	100	6	85	21	27	37	10	M5	Short
610021-029	100	8	85	21	27	37	10	M6	Short
610021-039	100	10	90	24	32	42	10	M8x1	Short
610021-049	100	12	95	24	32	48	10	M10x1	Short
610021-059	100	14	95	27	34	48	10	M10x1	Short
610021-069	100	16	100	27	34	51	10	M12x1	Short
610021-079	100	18	100	33	42	51	10	M12x1	Short
610021-089	100	20	105	33	42	53	10	M16x1	Short
610021-099	100	25	115	44	53	59	10	M16x1	Short
610021-519	100	6	130	21	27	37	10	M5	Long
610021-529	100	8	130	21	27	37	10	M6	Long
610021-539	100	10	130	24	32	42	10	M8x1	Long
610021-549	100	12	130	24	32	48	10	M10x1	Long
610021-569	100	16	130	27	34	51	10	M12x1	Long
610021-589	100	20	130	33	42	53	10	M16x1	Long
610021-619	100	6	160	21	27	37	10	M5	Extra long
610021-629	100	8	160	21	27	37	10	M6	Extra long
610021-639	100	10	160	24	32	42	10	M8x1	Extra long
610021-649	100	12	160	24	32	48	10	M10x1	Extra long
610021-669	100	16	160	27	34	51	10	M12x1	Extra long
610021-689	100	20	160	33	42	53	10	M16x1	Extra long

Shrink fit holder with 4 x „Cool Tool“ – Corrosion resistant

Application: Particularly suitable for tools without internal coolant, and for Machining at difficult positions with bad chip removal.

Technical Design: Made of special heat resistant steel. Suitable for inductive shrinking unit. With four additional threads for supplementary fine balancing. Runout of outer taper to $D1 \leq 0,003$ mm. The entire front area of the tool holder is corrosion resistant. Four holes in the toolholder lead the coolant directly to the cutting edge.

Includes: Set screw and 4 x M3-screws to plug the coolant holes if needed.

Accessories: See page 188.

FINE BALANCED
G 2,5 at 25.000^{min}-1 or max.
residual imbalance ≤ 1 gmm

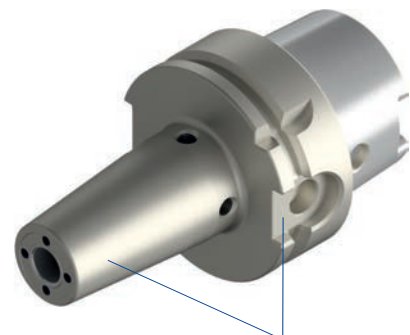
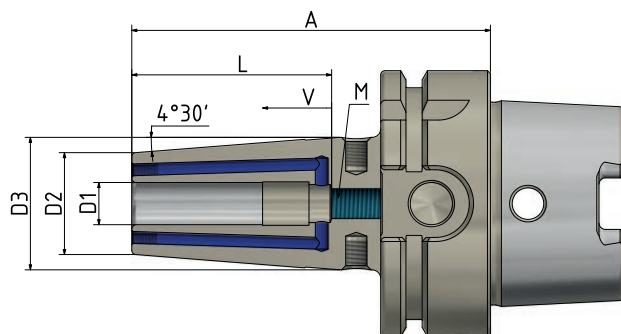

Corrosion resistant

Order No.	HSK	D1	A	D2	D3	L	V	M	Version
610048-018	100	6	85	21	27	37	10	M5	Short
610048-028	100	8	85	21	27	37	10	M6	Short
610048-038	100	10	90	24	32	42	10	M8x1	Short
610048-048	100	12	95	24	32	48	10	M10x1	Short
610048-068	100	16	100	27	34	51	10	M12x1	Short
610048-088	100	20	105	33	42	53	10	M16x1	Short

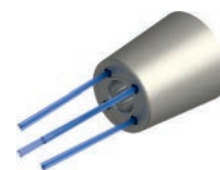

HSK-A 100

Shrink fit holder 3°

Application: For clamping tools with cylindrical shank of solid carbide or HSS, tol. h6.

Technical Design: Made of special heat resistant steel. Suitable for inductive shrinking unit. Runout of outer taper to $D1 \leq 0,003$ mm.

FINE BALANCED
G 2,5 at 25.000^{min}-1 or max.
residual imbalance ≤ 1 gmm

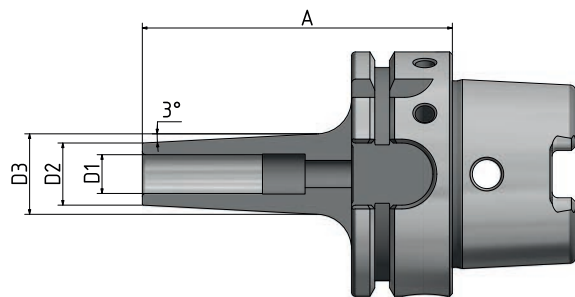

Order No.	HSK	D1	A	D2	D3	Version
610051-314	100	4	120	10	15	Long
610051-31	100	6	120	12	22	Long
610051-32	100	8	120	14	24	Long
610051-33	100	10	120	16	26	Long
610051-34	100	12	120	18	28	Long

Shell mill holder

Application: For adapting shell mills with transverse slot.

Technical Design: With extended flange.
Runout of outer taper to $D1 \leq 0,006$ mm.

Includes: Clamping screw and drive keys.

Accessories: See page 189.

FINE BALANCED
G 2,5 at 25.000^{min}-1 or max.
residual imbalance ≤ 1 gmm

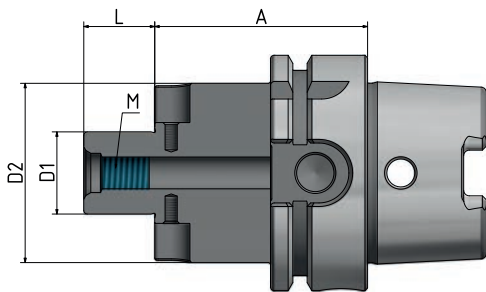

Fig. shows A = 160

Order No.	HSK	D1	A	D2	L1	M	Version
610005-01	100	16	50	38	17	M8	Short
610005-02	100	22	50	48	19	M10	Short
610005-03	100	27	50	60	21	M12	Short
610005-04	100	32	50	78	24	M16	Short
610005-05	100	40	60	89	27	M20	Short
610005-07	100	60	70	140	40	M30	Short
610005-011	100	16	100	38	17	M8	Long
610005-021	100	22	100	48	19	M10	Long
610005-031	100	27	100	60	21	M12	Long
610005-041	100	32	100	78	24	M16	Long
610005-051	100	40	100	89	27	M20	Long
610005-611	100	16	160	38	17	M8	Extra long
610005-621	100	22	160	48	19	M10	Extra long
610005-631	100	27	160	60	21	M12	Extra long
610005-641	100	32	160	78	24	M16	Extra long
610005-651	100	40	160	89	27	M20	Extra long

HSK-A 100

Shell mill holder „Cool Tool“

Application: For adapting shell mills with transverse slot, with coolant mandrel on the cutting edge.

Technical Design: With extended flange.
Runout of outer taper to $D1 \leq 0,006$ mm.

Includes: Clamping screw and drive keys.

Accessories: See page 189.

FINE BALANCED
G 2,5 at 25.000^{min}-1 or max.
residual imbalance ≤ 1 gmm

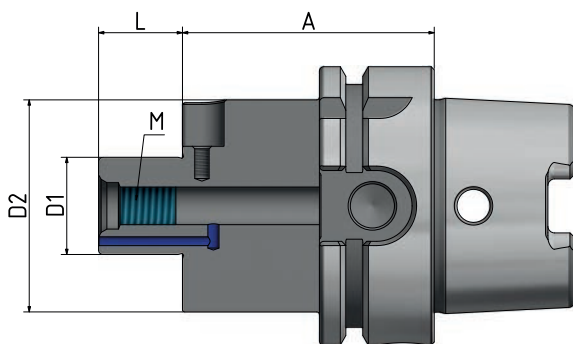

Fig. shows A = 160



Order No.	HSK	D1	A	D2	L1	M	Version
610005-21	100	16	50	38	17	M8	Short
610005-22	100	22	50	48	19	M10	Short
610005-23	100	27	50	60	21	M12	Short
610005-24	100	32	50	78	24	M16	Short
610005-25	100	40	60	89	27	M20	Short
610005-27	100	60	70	140	40	M30	Short
610005-211	100	16	100	38	17	M8	Long
610005-221	100	22	100	48	19	M10	Long
610005-231	100	27	100	60	21	M12	Long
610005-241	100	32	100	78	24	M16	Long
610005-251	100	40	100	89	27	M20	Long
610005-519	100	16	130	38	17	M8	Long
610005-529	100	22	130	48	19	M10	Long
610005-539	100	27	130	60	21	M12	Long
610005-549	100	32	130	78	24	M16	Long
610005-559	100	40	130	89	27	M20	Long
610005-619	100	16	160	38	17	M8	Extra long
610005-629	100	22	160	48	19	M10	Extra long
610005-639	100	27	160	60	21	M12	Extra long
610005-649	100	32	160	78	24	M16	Extra long
610005-659	100	40	160	89	27	M20	Extra long

Combi shell mill holder

- Application:** For adapting shell mills with transverse and longitudinal groove.
- Technical Design:** Runout of outer taper to $D1 \leq 0,006$ mm.
- Includes:** Clamping screw, drive key and adjusting spring.
- Accessories:** See page 190.

FINE BALANCED
G 2,5 at 25.000^{min}-1 or max.
residual imbalance ≤ 1 gmm

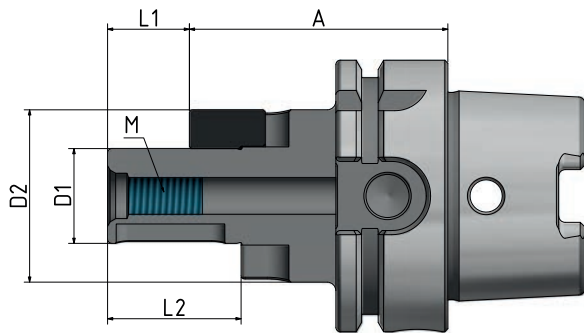

Fig. shows A = 160

Order No.	HSK	D1	A	D2	L1	L2	M	Version
610006-01	100	16	60	32	17	27	M8	Short
610006-02	100	22	60	40	19	31	M10	Short
610006-03	100	27	60	48	21	33	M12	Short
610006-04	100	32	60	58	24	38	M16	Short
610006-05	100	40	70	70	27	41	M20	Short
610006-011	100	16	100	32	17	27	M8	Long
610006-021	100	22	100	40	19	31	M10	Long
610006-031	100	27	100	48	21	33	M12	Long
610006-041	100	32	100	58	24	38	M16	Long
610006-051	100	40	100	70	27	41	M20	Long
610006-61	100	16	160	32	17	27	M8	Extra long
610006-62	100	22	160	40	19	31	M10	Extra long
610006-63	100	27	160	48	21	33	M12	Extra long
610006-64	100	32	160	58	24	38	M16	Extra long
610006-65	100	40	160	70	27	41	M20	Extra long

HSK-A 100

Morse taper adapter according to DIN 228A

Application For holding morse taper tools with tang according to DIN 228A.

Technical Design: Runout of outer taper to $D1 \leq 0,008$ mm.

 **BALANCED**
G 6,3 at 8.000^{min-1}

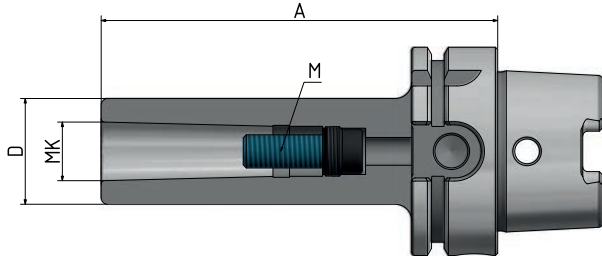

Order No.	HSK	MK	M	A	D	Version
610014-02	100	2	M10	120	32	Short
610014-03	100	3	M12	150	40	Short
610014-04	100	4	M16	170	48	Short

HSK-A 100

Morse taper adapter according to DIN 228B

Application: For holding morse taper tools with tang according to DIN 228B.

Technical Design: Runout of outer taper to $D1 \leq 0,008$ mm.

 **BALANCED**
G 6,3 at 8.000^{min-1}

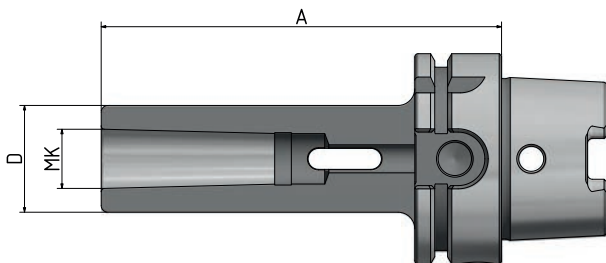

Order No.	HSK	MK	A	D	Version
610013-01	100	1	110	25	Short
610013-02	100	2	120	32	Short
610013-03	100	3	150	40	Short
610013-04	100	4	170	48	Short

Short drill chuck

Application: For clamping tools with cylindrical shank.
Also suitable for tools with internal coolant.

Includes: Wrench

 **BALANCED**
G 6,3 at 18.000^{min-1}

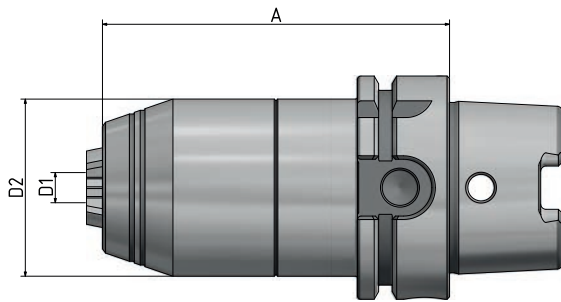

Order No.	HSK	Clamping range D1	A	D2
610095-52	100	1-16	104	50

HSK-A 40 + A 50

ER-Collet chuck

Application: For clamping tools with cylindrical shank in collets ER.

Technical Design: Runout of outer taper to inner taper $\leq 0,003$ mm.
Due to adjusted taper tolerances of the ER-Inner taper and the collet taper max. runout of $\leq 8 \mu$ at $2,5 \times D$.

Includes: Clamping nut.

Accessories: See page 183.

FINE BALANCED
G 2,5 at 25.000^{min-1} or max.
residual imbalance ≤ 1 gmm

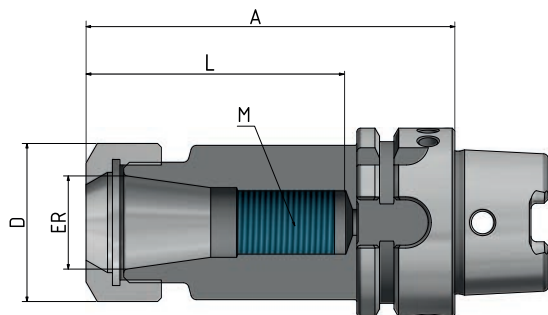

Fig. shows A = 100

Order No.	HSK	ER	D	A	Clamping range	L	M	Version
604002-001	40	16	28	60	1-10	38	-	Extra short
604002-002	40	25	42	70	1-16	47	-	Extra short
604002-003	40	32	50	70	2-20	49	-	Extra short
604002-07	40	11	19	80	1-7	48	M8x1	Short
604002-01	40	16	28	80	1-10	57	M11x1	Short
604002-02	40	25	42	80	1-16	61	M18x1,5	Short
604002-03	40	32	50	100	2-20	76	M24x1,5	Short

Order No.	HSK	ER	D	A	Clamping range	L	M	Version
605002-001	50	16	28	60	1-10	35	-	Extra short
605002-002	50	25	42	70	1-16	43	-	Extra short
605002-003	50	32	50	80	2-20	51	-	Extra short
605002-01	50	16	28	100	1-10	65	M11x1	Short
605002-02	50	25	42	100	1-16	73	M18x1,5	Short
605002-03	50	32	50	100	2-20	75	M24x1,5	Short



Sealed versions
see pages 186, 187.

Endmill holder Weldon

- Application:** For clamping tools with cylindrical shank according to DIN 1835B/6359HB.
- Technical Design:** Runout of outer taper to $D1 \leq 0,003$ mm. Tolerance of bore H4 (more accurate as DIN).
- Includes:** Clamping screw, from $\varnothing 25$ with 2 clamping screws.
- Accessories:** See page 188.

FINE BALANCED
G 2,5 at 25.000^{min}-1 or max.
residual imbalance ≤ 1 gmm

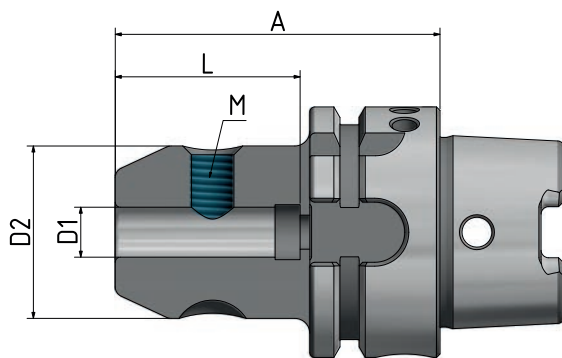

Order No.	HSK	D1	A	D2	L	M	Version
604004-01	40	6	60	25	35	M6	Short
604004-02	40	8	60	28	35	M8	Short
604004-03	40	10	60	35	41	M10	Short
604004-04	40	12	70	42	48	M12	Short
604004-05	40	14	75	44	48	M12	Short
604004-06	40	16	75	48	51	M14	Short

Order No.	HSK	D1	A	D2	L	M	Version
605004-01	50	6	65	25	35	M6	Short
605004-02	50	8	65	28	35	M8	Short
605004-03	50	10	65	35	41	M10	Short
605004-04	50	12	80	42	48	M12	Short
605004-06	50	16	80	48	51	M14	Short
605004-08	50	20	80	52	53	M16	Short

HSK-A 40 + A 50

Shrink fit holder 4,5°

Application: For clamping tools with cylindrical shank of solid carbide or HSS, tol. h6.

Technical Design: Made of special heat resistant steel. Suitable for inductive shrinking unit. With four additional threads for supplementary fine balancing. Runout of outer taper to $D1 \leq 0,003$ mm.

Includes: Set screw.

Accessories: See page 188.

FINE BALANCED
G 2,5 at 25.000^{min}-1 or max.
residual imbalance ≤ 1 gmm

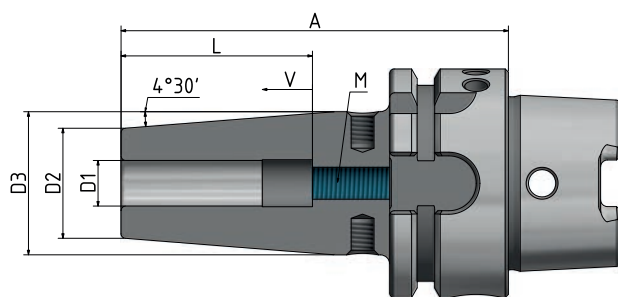

Order No.	HSK	D1	A	D2	D3	L	V	M	Version
604021-13	40	3	60	12	17	-	-	-	Short
604021-14	40	4	60	12	17	-	-	-	Short
604021-15	40	5	60	12	17	-	-	-	Short
604021-01	40	6	80	21	27	37	10	M5	Short
604021-02	40	8	80	21	27	37	10	M6	Short
604021-03	40	10	80	24	32	42	10	M8x1	Short
604021-04	40	12	90	24	32	48	10	M10x1	Short
604021-05	40	14	90	27	34	48	10	M10x1	Short
604021-06	40	16	90	27	34	51	10	M12x1	Short

Order No.	HSK	D1	A	D2	D3	L	V	M	Version
605021-13	50	3	60	12	17	-	-	-	Short
605021-14	50	4	60	12	17	-	-	-	Short
605021-15	50	5	60	12	17	-	-	-	Short
605021-01	50	6	80	21	27	37	10	M5	Short
605021-02	50	8	80	21	27	37	10	M6	Short
605021-03	50	10	85	24	32	42	10	M8x1	Short
605021-04	50	12	90	24	32	48	10	M10x1	Short
605021-05	50	14	90	27	34	48	10	M10x1	Short
605021-06	50	16	95	27	34	51	10	M12x1	Short
605021-07	50	18	95	33	42	51	10	M12x1	Short
605021-08	50	20	100	33	42	53	10	M16x1	Short

Shell mill holder

Application: For adapting shell mills with transverse slot.

Technical Design: With extended flange.
Runout of outer taper to $D1 \leq 0,006$ mm.

Includes: Clamping screw and drive keys.

Accessories: See page 189.

 **FINE BALANCED**
G 2,5 at 25.000^{min}-1 or max.
residual imbalance ≤ 1 gmm

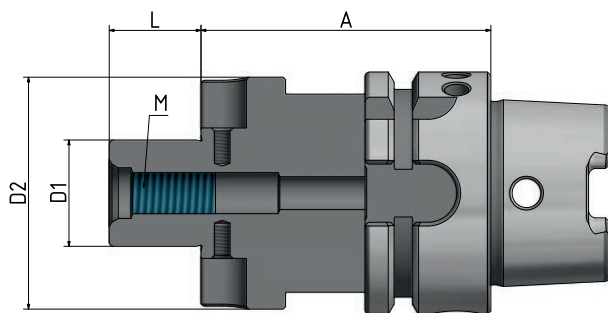

Order No.	HSK	D1	A	D2	L1	M	Version
604005-01	40	16	50	38	17	M8	Short
604005-02	40	22	60	48	19	M10	Short

Order No.	HSK	D1	A	D2	L1	M	Version
605005-01	50	16	50	38	17	M8	Short
605005-02	50	22	60	48	19	M10	Short
605005-03	50	27	60	60	21	M12	Short

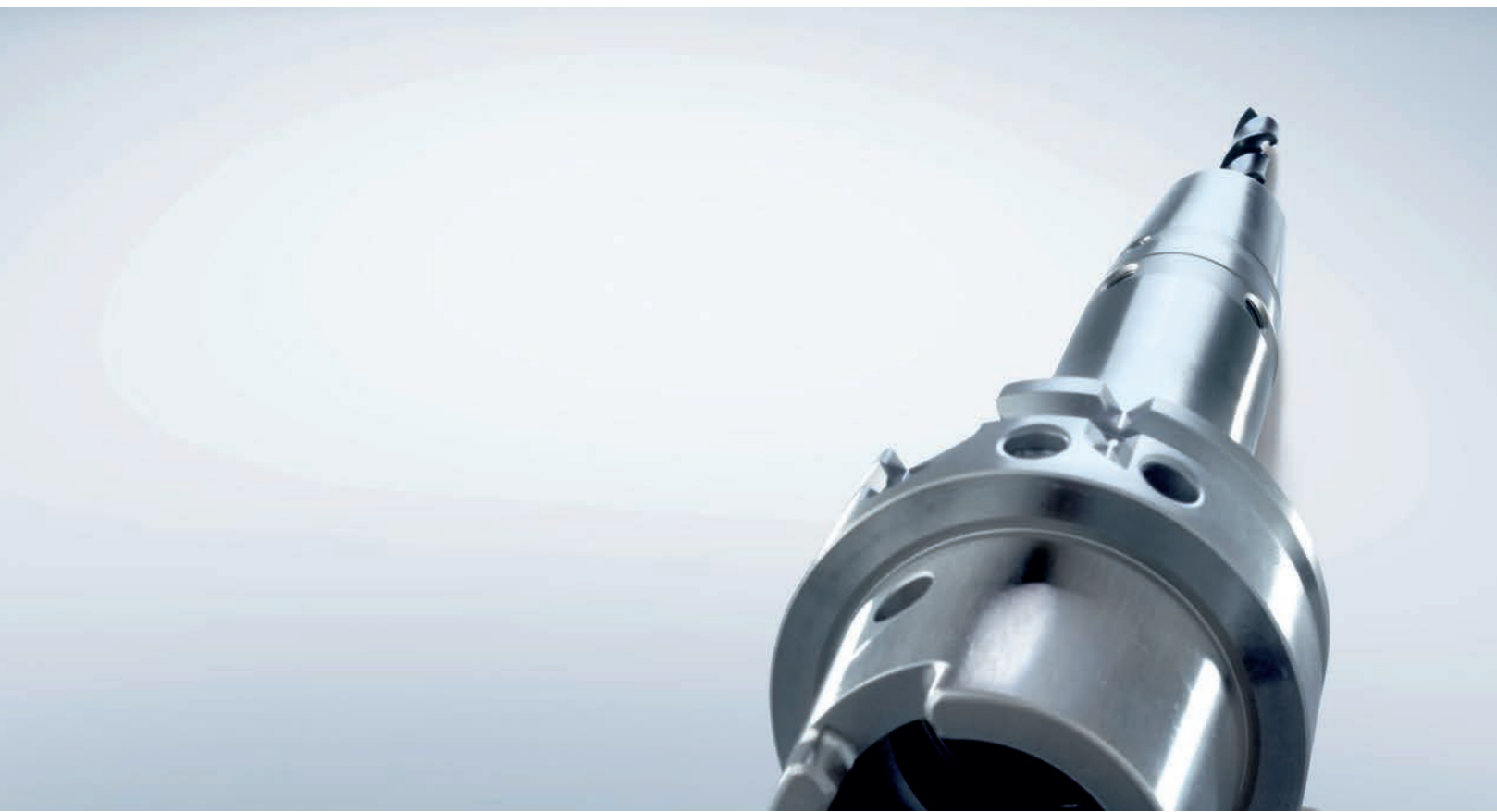

TOOL HOLDER

DIN 69893-5

HSK-FORM E 32, E 40 + E 50

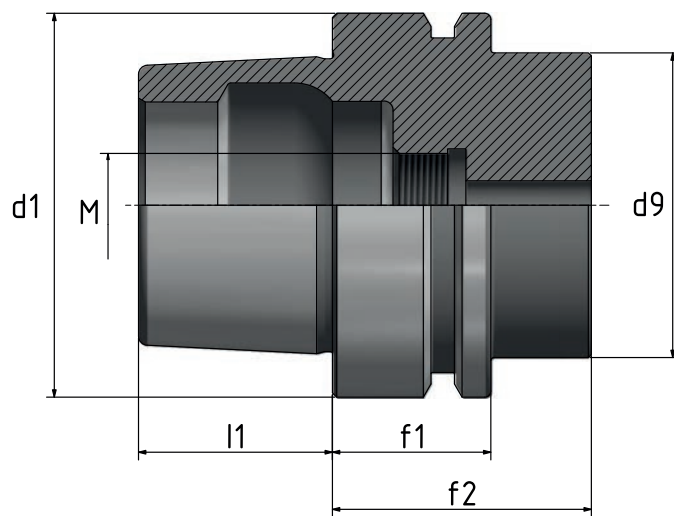

HSK	d1	d9 max.	l1	f1	f2 min.	M
32	32	26	16	20	35	M10x1
40	40	34	20	20	35	M12x1
50	50	42	25	26	42	M16x1

HSK-E 32, E 40 + E 50

HPC – Precision ER collet chuck HAWK EYE®

Application: For clamping tools with cylindrical shank in collets ER.

Technical Design: Due to high precision taper tolerances of the ER-Inner taper and the collet taper max. runout of $\leq 5 \mu$ at $2,5 \times D$, subject the usage of our HP 2μ ER collets. The deep fit of the collet inside the chuck combined with a surface treated clamping nut achieves more than double clamping force compared to standard ER collet chuck. HAWK EYE® has an enforced body for max. radial rigidity. The patented special design of HAWK EYE® chuck is only suitable to clamp nominal diameters of the collet used.

Includes: Special clamping nut.

Accessories: See page 183.

FINE BALANCED
G 2,5 at 25.000^{min-1} or max.
residual imbalance ≤ 1 gmm

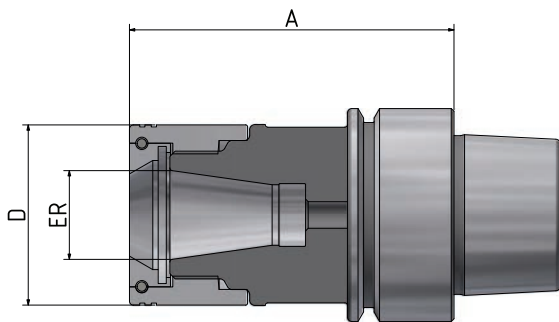

Fig. shows A = 60

Order No.	HSK	ER	D	A	Clamping range*	L	M	Version
404032-02	40	16	34	60	1–10	32	–	Short
404032-04	40	25	44	65	1–16	39	–	Short

Order No.	HSK	ER	D	A	Clamping range*	L	M	Version
405032-002	50	16	34	60	1–10	32	–	Short
405032-004	50	25	44	70	1–16	39	–	Short

HPC – Precision ER collet chuck HAWK EYE® „Mini“

Application: For clamping tools with cylindrical shank in collets ER.

Technical Design: Due to high precision taper tolerances of the ER-Inner taper and the collet taper max. runout of $\leq 5 \mu$ at $2,5 \times D$, subject the usage of our HP 2μ ER collets. The deep fit of the collet inside the chuck combined with a surface treated clamping nut achieves more than double clamping force compared to standard ER collet chuck. HAWK EYE® has an enforced body for max. radial rigidity. The patented special design of HAWK EYE® chuck is only suitable to clamp nominal diameters of the collet used.

Includes: Special clamping nut.

Accessories: See page 183.

FINE BALANCED
G 2,5 at 25.000^{min}-1 or max.
residual imbalance ≤ 1 gmm

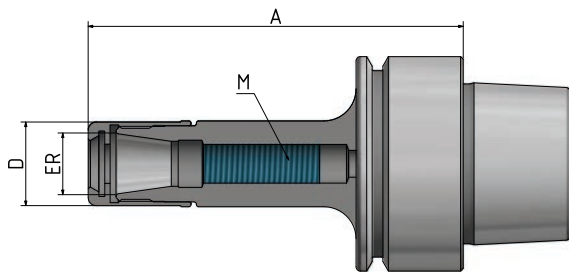

Fig. shows A = 70

Order No.	HSK	ER	D	A	Clamping range*	L	M	Version
404034-001	40	11	16	70	1–7	32	M8x1	Short
404034-002	40	16	24	70	1–10	39	M11x1	Short

Order No.	HSK	ER	D	A	Clamping range*	L	M	Version
405034-01	50	11	16	100	1–7	32	M8x1	Short
405034-02	50	16	24	100	1–10	39	M11x1	Short

HSK-E 40 + E 50

ER-Collet chuck

Application: For clamping tools with cylindrical shank in collets ER.

Technical Design: Runout of outer taper to inner taper $\leq 0,003$ mm.
Due to adjusted taper tolerances of the ER-Inner taper and the collet taper max. runout of $\leq 8 \mu$ at $2,5 \times D$.

Includes: Clamping nut.

Accessories: See page 183.

FINE BALANCED
G 2,5 at 25.000^{min-1} or max.
residual imbalance ≤ 1 gmm

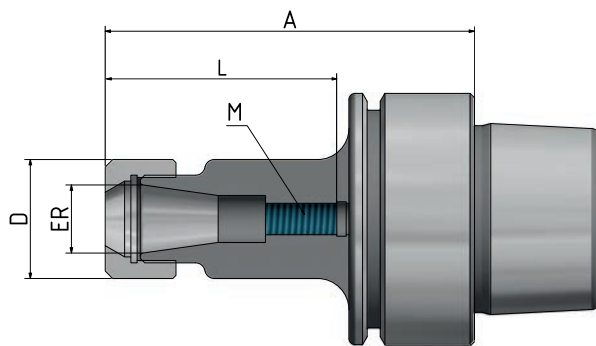

Fig. shows A = 100

Order No.	HSK	ER	Clamping range			D	L	M	Version
			A	range					
403202-02	32	16	80	1-10	28	60	M11x1	Short	
403202-04	32	25	80	1-16	42	59	M18x1,5	Short	
403202-32	32	16	100	1-10	28	60	M11x1	Long	

Order No.	HSK	ER	Clamping range			D	L	M	Version
			A	range					
404002-001	40	11	60	1-7	19	36	-	Extra short	
404002-002	40	16	60	1-10	28	38	-	Extra short	
404002-003	40	25	70	1-16	42	47	-	Extra short	
404002-01	40	16	80	1-10	28	57	M11x1	Short	
404002-02	40	25	80	1-16	42	61	M18x1,5	Short	

Order No.	HSK	ER	Clamping range			D	L	M	Version
			A	range					
405002-001	50	11	60	1-10	28	35	-	Extra short	
405002-002	50	16	70	1-16	42	43	-	Extra short	
405002-003	50	25	80	2-20	50	51	-	Extra short	
405002-007	50	32	60	1-7	19	34	-	Extra short	
405002-01	50	16	100	1-10	28	65	M11x1	Short	
405002-03	50	25	100	1-16	42	73	M18x1,5	Short	
405002-04	50	32	100	2-20	50	75	M24x1,5	Short	



Sealed versions
see pages 186, 187.

Shrink fit holder 4,5°

Application: For clamping tools with cylindrical shank of solid carbide or HSS, tol. h6.

Technical Design: Made of special heat resistant steel. Suitable for inductive shrinking unit. With four additional threads for supplementary fine balancing. Runout of outer taper to D1 \leq 0,003 mm.

Includes: Set screw.

Accessories: See page 188.

FINE BALANCED
G 2,5 at 25.000^{min}-1 or max.
residual imbalance \leq 1 gmm

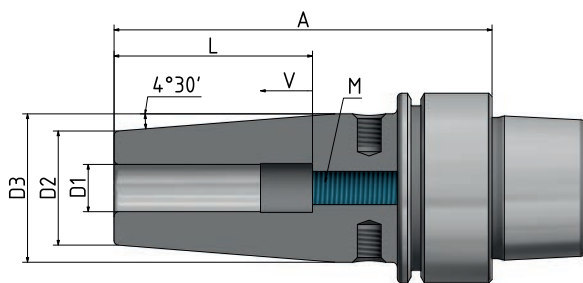

Fig. shows A = 90

Order No.	HSK	D1	A	D2	D3	L	V	M	Version
403221-13	32	3	60	12	17	-	-	-	Short
403221-14	32	4	60	12	17	-	-	-	Short
403221-15	32	5	60	12	17	-	-	-	Short
403221-01	32	6	70	21	27	37	10	M5	Short
403221-02	32	8	70	21	27	37	10	M6	Short
403221-03	32	10	80	24	32	42	10	M8x1	Short

Order No.	HSK	D1	A	D2	D3	L	V	M	Version
404021-001*	40	6	60	21	27	36	-	-	Extra short
404021-002*	40	8	60	21	27	36	-	-	Extra short
404021-003*	40	10	60	24	32	42	-	-	Extra short
404021-004**	40	12	60	24	32	47	-	-	Extra short
404021-006**	40	16	60	27	34	50	-	-	Extra short

Order No.	HSK	D1	A	D2	D3	L	V	M	Version
404021-13	40	3	60	12	17	-	-	-	Short
404021-14	40	4	60	12	17	-	-	-	Short
404021-15	40	5	60	12	17	-	-	-	Short
404021-01	40	6	80	21	27	37	10	M5	Short
404021-02	40	8	80	21	27	37	10	M6	Short
404021-03	40	10	80	24	32	42	10	M8x1	Short
404021-04	40	12	90	24	32	48	10	M10x1	Short
404021-05	40	14	90	27	34	48	10	M10x1	Short
404021-06	40	16	90	27	34	51	10	M12x1	Short

*Without balancing thread.

** Without balancing thread and without thread for coolant tube.

HSK-E 50

Shrink fit holder 4,5° (Continuation)

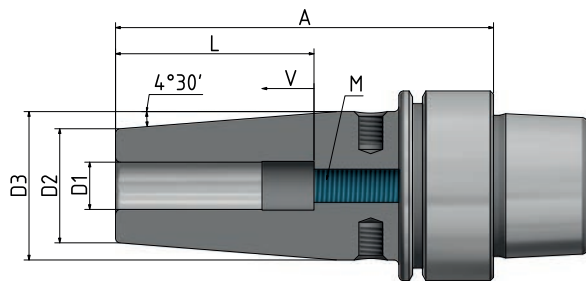

Fig. shows A = 90

Order No.	HSK	D1	A	D2	D3	L	V	M	Version
405021-13	50	3	60	12	17	-	-	-	Short
405021-14	50	4	60	12	17	-	-	-	Short
405021-15	50	5	60	12	17	-	-	-	Short
405021-01	50	6	80	21	27	37	10	M5	Short
405021-02	50	8	80	21	27	37	10	M6	Short
405021-03	50	10	85	24	32	42	10	M8x1	Short
405021-04	50	12	90	24	32	48	10	M10x1	Short
405021-05	50	14	90	27	34	48	10	M10x1	Short
405021-06	50	16	95	27	34	51	10	M12x1	Short

Shrink fit holder 3°

Application: For clamping tools with cylindrical shank of solid carbide or HSS, tol. h6.

Technical Design: Made of special heat resistant steel. Suitable for inductive shrinking unit. Runout of outer taper to $D1 \leq 0,003$ mm.

FINE BALANCED
G 2,5 at 40.000^{min}-1 or max.
residual imbalance ≤ 1 gmm

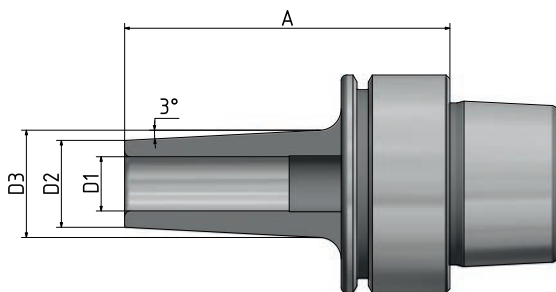

Fig. shows A = 80

Order No.	HSK	D1	A	D2	D3	Version
404051-13	40	3	60	9	14	Extra short
404051-14	40	4	60	10	15	Extra short
404051-15	40	5	60	11	16	Extra short
404051-01	40	6	60	12	17	Extra short
404051-02	40	8	60	14	19	Extra short
404051-03	40	10	60	16	21	Extra short
404051-04	40	12	60	18	23	Extra short
404051-313	40	3	70	9	15	Short
404051-314	40	4	70	10	16	Short
404051-315	40	5	70	11	17	Short
404051-31	40	6	70	12	18	Short
404051-32	40	8	70	14	20	Short
404051-33	40	10	70	16	22	Short
404051-34	40	12	70	18	24	Short
404051-513	40	3	80	9	16	Long
404051-514	40	4	80	10	17	Long
404051-515	40	5	80	11	18	Long
404051-51	40	6	80	12	19	Long
404051-52	40	8	80	14	21	Long
404051-53	40	10	80	16	23	Long
404051-54	40	12	80	18	25	Long

HSK-E 40

Shrink fit holder 3° – extra slim, short

Application: For clamping tools with cylindrical shank of solid carbide or HSS, tol. h6.

Technical Design: Made of special heat resistant steel. Suitable for inductive shrinking unit. Runout of outer taper to D1 \leq 0,003 mm.

FINE BALANCED
G 2,5 at 40.000^{min}-1 or max.
residual imbalance \leq 1 gmm

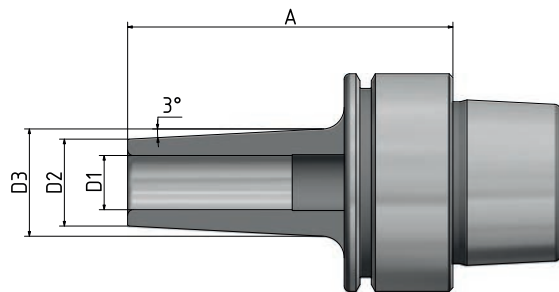

Order No.	HSK	D1	A	D2	D3	Version
404052-13	40	3	60	6	10	Extra slim, short
404052-14	40	4	60	7	11	Extra slim, short
404052-15	40	5	60	8	12	Extra slim, short
404052-01	40	6	60	9	13	Extra slim, short
404052-02	40	8	60	11	15	Extra slim, short
404052-03	40	10	60	13	17	Extra slim, short
404052-04	40	12	60	15	19	Extra slim, short

Shrink fit holder 3°

Application: For clamping tools with cylindrical shank of solid carbide or HSS, tol. h6.

Technical Design: Made of special heat resistant steel. Suitable for inductive shrinking unit. Runout of outer taper to $D1 \leq 0,003$ mm.

FINE BALANCED
G 2,5 at 40.000^{min}-1 or max.
residual imbalance ≤ 1 gmm

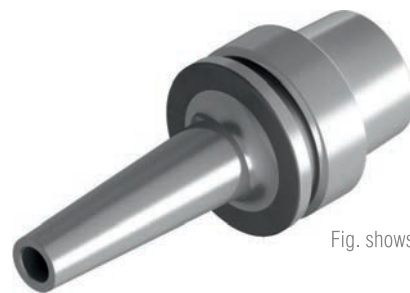
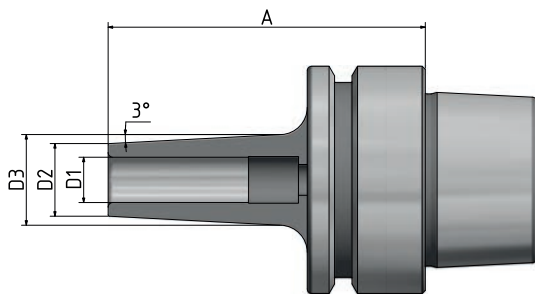
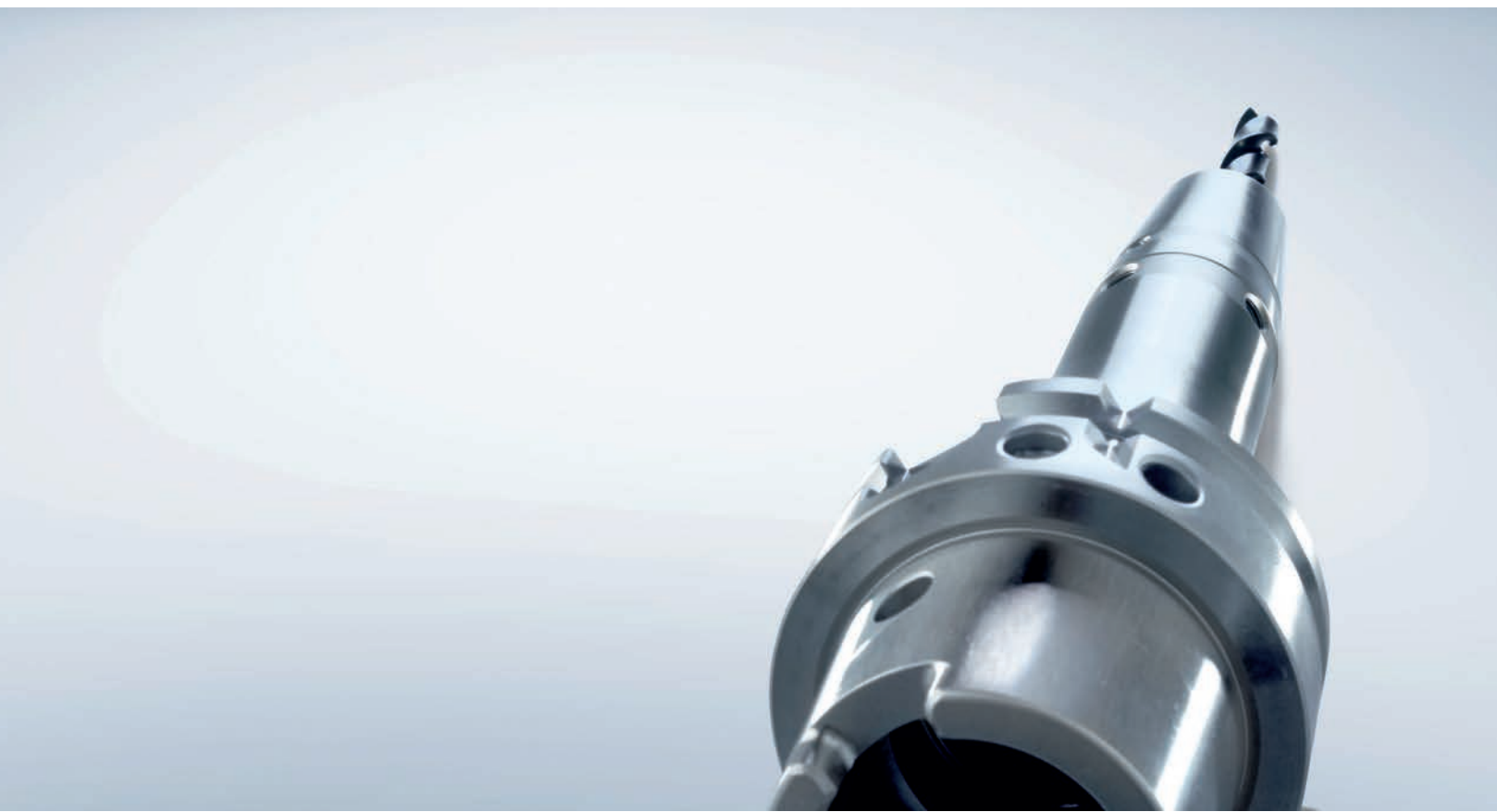

Fig. shows A = 100

Order No.	HSK	D1	A	D2	D3	Version
405051-13	50	3	70	9	14	Extra short
405051-14	50	4	70	10	15	Extra short
405051-15	50	5	70	11	16	Extra short
405051-01	50	6	70	12	17	Extra short
405051-02	50	8	70	14	19	Extra short
405051-03	50	10	70	16	21	Extra short
405051-04	50	12	70	18	23	Extra short
405051-313	50	3	80	9	15	Short
405051-314	50	4	80	10	16	Short
405051-315	50	5	80	11	17	Short
405051-31	50	6	80	12	18	Short
405051-32	50	8	80	14	20	Short
405051-33	50	10	80	16	22	Short
405051-34	50	12	80	18	24	Short
405051-513	50	3	100	9	17	Long
405051-514	50	4	100	10	18	Long
405051-515	50	5	100	11	19	Long
405051-51	50	6	100	12	20	Long
405051-52	50	8	100	14	22	Long
405051-53	50	10	100	16	24	Long
405051-54	50	12	100	18	26	Long



TOOL HOLDER

DIN 69893-6

HSK-F 63

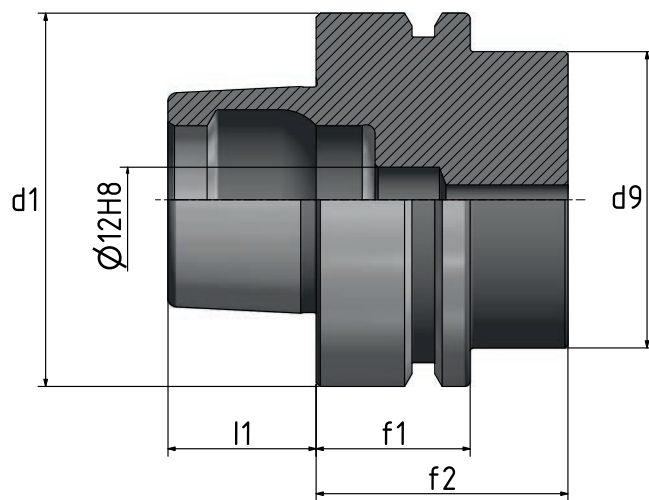

HSK	d1	d9 max.	l1	f1	f2 min.
63	63	53	25	26	42

HSK-F 63

HPC – Precision ER collet chuck HAWK EYE®

Application: For clamping tools with cylindrical shank in collets ER.

Technical Design: Due to high precision taper tolerances of the ER-Inner taper and the collet taper max. runout of $\leq 5 \mu$ at $2,5 \times D$, subject the usage of our HP 2μ ER collets. The deep fit of the collet inside the chuck combined with a surface treated clamping nut achieves more than double clamping force compared to standard ER collet chuck. HAWK EYE® has an enforced body for max. radial rigidity. The patented special design of HAWK EYE® chuck is only suitable to clamp nominal diameters of the collet used.

Includes: Special clamping nut.

Accessories: See page 183.

 **FINE BALANCED**
G 2,5 at 25.000^{min}-1 or max.
residual imbalance ≤ 1 gmm

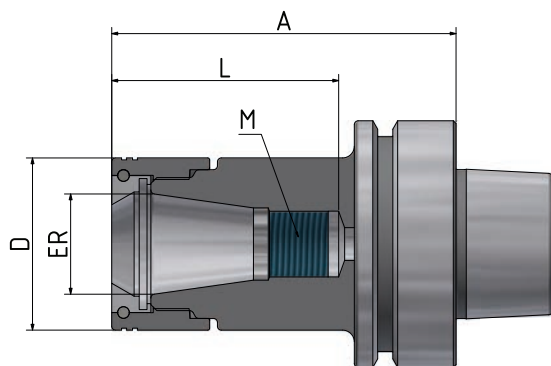

Fig. shows A = 100

Order No.	HSK	ER	D	A	Clamping range	L	M	Version
206332-002	63	16	34	75	1–10	46	–	Extra short
206332-004	63	25	44	75	1–16	48	–	Extra short
206332-02	63	16	34	100	1–10	58	M11x1	Short
206332-04	63	25	44	100	1–16	69	M18x1,5	Short
206332-05	63	32	52	100	2–20	73	M24x1,5	Short
206332-06	63	40	62	100	4–26	80	M28x1,5	Short

ER-Collet chuck

Application: For clamping tools with cylindrical shank in collets ER.

Technical Design: Runout of outer taper to inner taper $\leq 0,003$ mm.
Due to adjusted taper tolerances of the ER-Inner taper and the collet taper max. runout of $\leq 8 \mu$ at $2,5 \times D$.

Includes: Clamping nut.

Accessories: See page 183.

FINE BALANCED
G 2,5 at 25.000^{min-1} or max.
residual imbalance ≤ 1 gmm

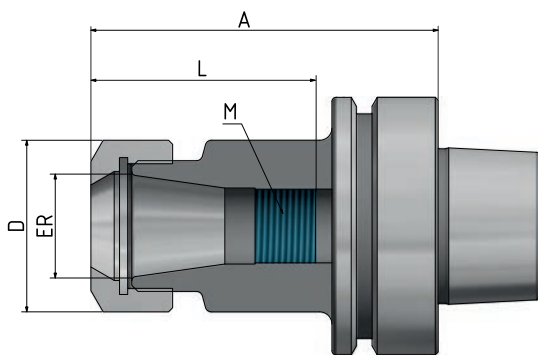

Fig. shows A = 100

Order No.	HSK	ER	D	A	Clamping range	L	M	Version
206302-001	63	11	19	75	1-7	41	-	Extra short
206302-002	63	16	28	75	1-10	45	-	Extra short
206302-003	63	20	34	75	1-13	49	-	Extra short
206302-004	63	25	42	75	1-16	47	-	Extra short
206302-005	63	32	50	75	2-20	51	-	Extra short
206302-006	63	40	63	75	4-26	54	-	Extra short
206302-01	63	11	19	100	1-7	49	M8x1	Short
206302-02	63	16	28	100	1-10	65	M11x1	Short
206302-03	63	20	34	100	1-13	71	M14x1	Short
206302-04	63	25	42	100	1-16	73	M18x1,5	Short
206302-05	63	32	50	100	2-20	78	M24x1,5	Short
206302-06	63	40	63	120	4-26	95	M28x1,5	Short



Sealed versions
see pages 186, 187.

HSK-F 63

Shrink fit holder 4,5°

Application: For clamping tools with cylindrical shank of solid carbide or HSS, tol. h6.

Technical Design: Made of special heat resistant steel. Suitable for inductive shrinking unit. With four additional threads for supplementary fine balancing. Runout of outer taper to $D1 \leq 0,003$ mm.

Includes: Set screw.

Accessories: See page 188.

 **FINE BALANCED**
G 2,5 at 25.000^{min}-1 or max.
residual imbalance ≤ 1 gmm

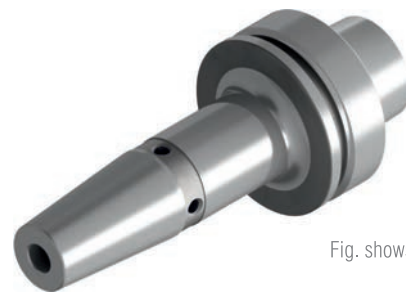
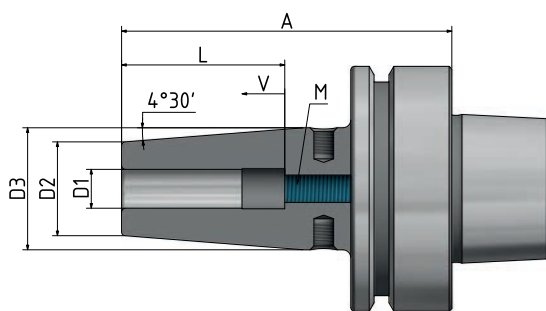

Fig. shows A = 130

Order No.	HSK	D1	A	D2	D3	V	L	M	Version
206321-13	63	3	80	12	17	—	—	—	Short
206321-14	63	4	80	12	17	—	—	—	Short
206321-15	63	5	80	12	17	—	—	—	Short
206321-01	63	6	80	21	27	10	37	M5	Short
206321-02	63	8	80	21	27	10	37	M6	Short
206321-03	63	10	85	24	32	10	42	M8x1	Short
206321-04	63	12	90	24	32	10	48	M10x1	Short
206321-06	63	16	95	27	34	10	51	M12x1	Short
206321-08	63	20	100	33	42	10	53	M16x1	Short
206321-09	63	25	115	44	53	10	59	M16x1	Short
206321-51	63	6	130	21	27	10	37	M5	Long
206321-52	63	8	130	21	27	10	37	M6	Long
206321-53	63	10	130	24	32	10	42	M8x1	Long
206321-54	63	12	130	24	32	10	48	M10x1	Long
206321-56	63	16	130	27	34	10	51	M12x1	Long
206321-58	63	20	130	33	42	10	53	M16x1	Long
206321-59	63	25	130	44	53	10	59	M16x1	Long

Shell mill holder „Cool Tool“

Application: For adapting shell mills with transverse slot, with coolant mandrel on the cutting edge.

Technical Design: With extended flange.
Runout of outer taper to $D1 \leq 0,006$ mm.

Includes: Clamping screw and drive keys.

Accessories: See page 189.

 **FINE BALANCED**
G 2,5 at 25.000^{min}-1 or max.
residual imbalance ≤ 1 gmm

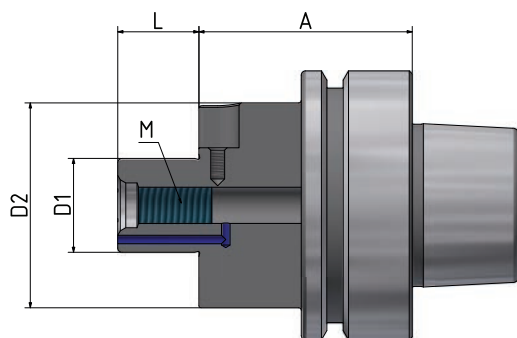

Order No.	HSK	D1	A	D2	L1	M	Version
206305-22	63	22	50	48	19	M10	Short
206305-23	63	27	60	60	21	M12	Short





TOOL HOLDER

ISO 7388-1, FORM AD/AF

FORMER DIN 69871, FORM AD/B

SK 40 AND SK 50

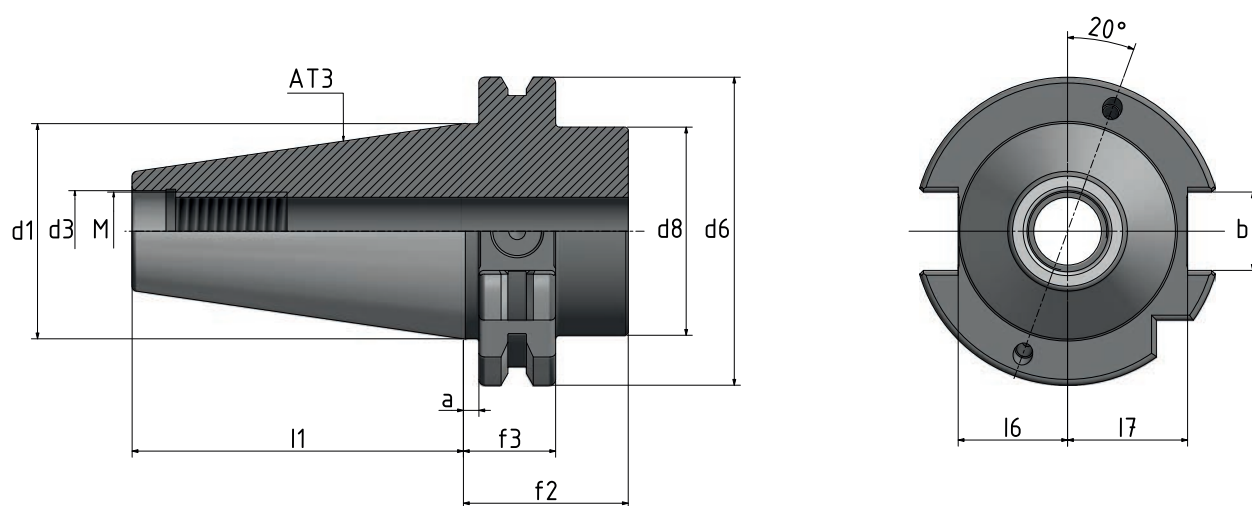

SK	l1	d1	d6	f3	f2 min.	a	M	d3	d8 max.	b	l6	l7
40	68,4	44,45	63,55	19,1	35	3,2	M16	17	50	16,1	22,8	25
50	101,75	69,85	97,5	19,1	35	3,2	M24	25	80	25,7	35,5	37,7

SK 40 ISO 7388-1 Form AD/AF

HPC – Precision ER collet chuck HAWK EYE®

Application: For clamping tools with cylindrical shank in collets ER.

Technical Design: Due to high precision taper tolerances of the ER-Inner taper and the collet taper max. runout of $\leq 5 \mu$ at $2,5 \times D$, subject the usage of our HP 2μ ER collets. The deep fit of the collet inside the chuck combined with a surface treated clamping nut achieves more than double clamping force compared to standard ER collet chuck. HAWK EYE® has an enforced body for max. radial rigidity. The patented special design of HAWK EYE® chuck is only suitable to clamp nominal diameters of the collet used.

Includes: Special clamping nut.

Accessories: See page 183.

FINE BALANCED
G 2,5 at 25.000^{min}-1 or max.
residual imbalance ≤ 1 gmm

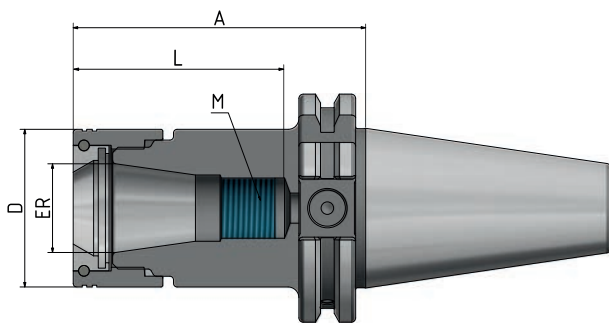

Fig. shows A = 160

Order No.	SK	ER	D	A	Clamping range	L	M	Version
714032-02	40	16	34	70	1–10	52	M11x1	Short
714032-03	40	20	38	70	1–13	57	M14x1	Short
714032-04	40	25	44	70	1–16	69	M18x1,5	Short
714032-05	40	32	52	70	2–20	78	M24x1,5	Short
714032-06	40	40	62	70	4–26	87	M28x1,5	Short
714032-32	40	16	34	100	1–10	100	M11x1	Long
714032-34	40	25	44	100	1–16	69	M18x1,5	Long
714032-35	40	32	52	100	2–20	78	M24x1,5	Long
714032-36	40	40	62	100	4–26	92	M28x1,5	Long
714032-52	40	16	34	130	1–10	130	M11x1	Long
714032-54	40	25	44	130	1–16	69	M18x1,5	Long
714032-55	40	32	52	130	2–20	78	M24x1,5	Long
714032-62	40	16	34	160	1–10	160	M11x1	Extra long
714032-64	40	25	44	160	1–16	69	M18x1,5	Extra long
714032-65	40	32	52	160	2–20	78	M24x1,5	Extra long



Sealed versions
see pages 186, 187.

HPC – Precision ER collet chuck HAWK EYE® „Mini“

Application: For clamping tools with cylindrical shank in collets ER.

Technical Design: Due to high precision taper tolerances of the ER-Inner taper and the collet taper max. runout of $\leq 5 \mu$ at $2,5 \times D$, subject the usage of our HP 2μ ER collets. The deep fit of the collet inside the chuck combined with a surface treated clamping nut achieves more than double clamping force compared to standard ER collet chuck. HAWK EYE® has an enforced body for max. radial rigidity. The patented special design of HAWK EYE® chuck is only suitable to clamp nominal diameters of the collet used.

Includes: Special clamping nut.

Accessories: See page 183.

FINE BALANCED
G 2,5 at 25.000^{min-1} or max.
residual imbalance ≤ 1 gmm

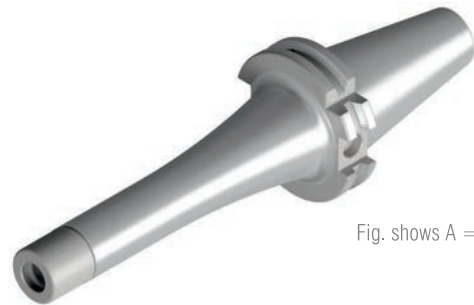
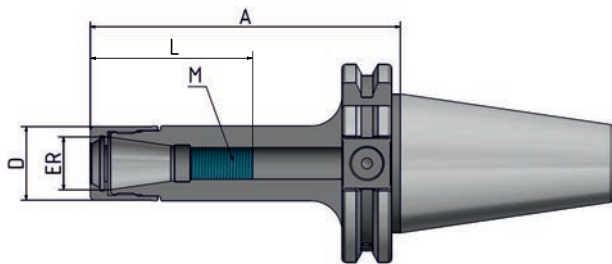

Fig. shows A = 160

Order No.	SK	ER	D	A	Clamping range	L	M	Version
714034-31	40	11	16	100	1–7	48	M8x1	Short
714034-32	40	16	24	100	1–10	80	M11x1	Short
714034-61	40	11	16	160	1–7	49	M8x1	Extra long
714034-62	40	16	24	160	1–10	140	M11x1	Extra long



Sealed versions
see pages 186, 187.

SK 40 ISO 7388-1 Form AD/AF

ER-Collet chuck

Application: For clamping tools with cylindrical shank in collets ER.

Technical Design: Runout of outer taper to inner taper $\leq 0,003$ mm.
Due to adjusted taper tolerances of the ER-Inner taper and the collet taper max. runout of $\leq 8 \mu$ at $2,5 \times D$.

Includes: Clamping nut.

Accessories: See page 183.

FINE BALANCED
G 2,5 at 25.000^{min}-1 or max.
residual imbalance ≤ 1 gmm

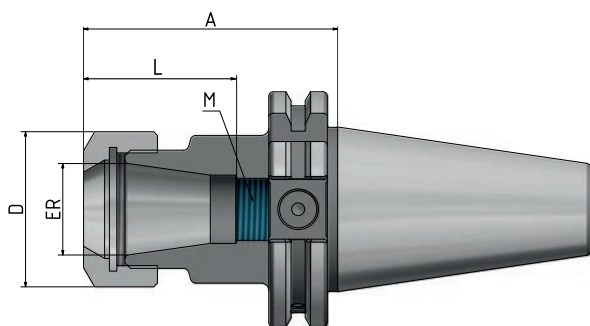

Fig. shows A = 200

Order No.	SK	ER	Clamping range		A	D	L	M	Version
			ER	Clamping range					
714002-01	40	16	1-10	70	28	55	M11x1	Short	
714002-02	40	20	1-13	70	34	55	M14x1	Short	
714002-03	40	25	1-16	70	42	75	M18x1,5	Short	
714002-04	40	32	2-20	70	50	82	M24x1,5	Short	
714002-05	40	40	4-26	70	63	86	M28x1,5	Short	
714002-31	40	16	1-10	100	28	50	M11x1	Long	
714002-32	40	20	1-13	100	34	80	M14x1	Long	
714002-33	40	25	1-16	100	42	75	M18x1,5	Long	
714002-34	40	32	2-20	100	50	82	M24x1,5	Long	
714002-35	40	40	4-26	100	63	96	M28x1,5	Long	
714002-61	40	16	1-10	160	28	140	M11x1	Extra long	
714002-63	40	25	1-16	160	42	75	M18x1,5	Extra long	
714002-64	40	32	2-20	160	50	82	M24x1,5	Extra long	
714002-65	40	40	4-26	160	63	96	M28x1,5	Extra long	
714002-81	40	16	1-10	200	28	170	M11x1	Extra long	
714002-83	40	25	1-16	200	42	75	M18x1,5	Extra long	
714002-84	40	32	2-20	200	50	82	M24x1,5	Extra long	



Sealed versions
see pages 186, 187.

ER-Collet chuck „Mini“

Application: For clamping tools with cylindrical shank in collets ER.

Technical Design: Runout of outer taper to inner taper $\leq 0,003$ mm.
Due to adjusted taper tolerances of the ER-Inner taper and the collet taper max. runout of $\leq 8 \mu$ at $2,5 \times D$.

Includes: Clamping nut.

Accessories: See page 183.

FINE BALANCED
G 2,5 at 25.000^{min}-1 or max.
residual imbalance ≤ 1 gmm

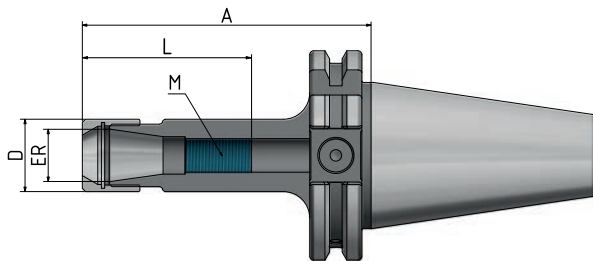

Fig. shows A = 160

Order No.	SK	ER	Clamping range	A	D	L	M	Version
714002-21	40	11	1–7	70	16	51	M8x1	Short
714002-23	40	16	1–10	70	22	70	M11x1	Short
714002-41	40	11	1–7	100	16	49	M8x1	Long
714002-43	40	16	1–10	100	22	85	M11x1	Long
714002-47	40	20	1–13	100	28	98	M14x1	Long
714002-45	40	25	1–16	100	35	75	M18x1,5	Long
714002-51	40	11	1–7	130	16	49	M8x1	Long
714002-52	40	16	1–10	130	22	130	M11x1	Long
714002-53	40	20	1–13	130	28	130	M14x1	Long
714002-54	40	25	1–16	130	35	75	M18x1,5	Long
714002-42	40	11	1–7	160	16	49	M8x1	Extra long
714002-44	40	16	1–10	160	22	150	M11x1	Extra long
714002-48	40	20	1–13	160	28	150	M14x1	Extra long
714002-46	40	25	1–16	160	35	75	M18x1,5	Extra long

SK 40 ISO 7388-1 Form AD/AF

ER-Collet chuck – Corrosion resistant

Application: For clamping tools with cylindrical shank in collets ER.

Technical Design: The entire front area of the tool holder is corrosion resistant.
Runout of outer taper to inner taper $\leq 0,003$ mm.
Due to adjusted taper tolerances of the ER-Inner taper and the collet taper max. runout of $\leq 8\mu$ at 2,5 X D.

Includes: Clamping nut.

Accessories: See page 183.

FINE BALANCED
G 2,5 at 25.000^{min}-1 or max.
residual imbalance ≤ 1 gmm

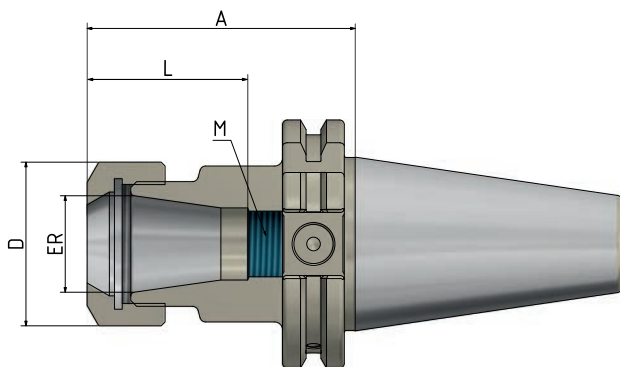

Order No.	SK	ER	D	A	Clamping range	L	M	Version
7140028-01	40	16	28	70	1-10	55	M11x1	Short
7140028-03	40	25	42	70	1-16	75	M18x1,5	Short
7140028-04	40	32	50	70	2-20	82	M24x1,5	Short
7140028-05	40	40	63	70	4-26	86	M28x1,5	Short

Endmill holder Weldon

- Application:** For clamping tools with cylindrical shank according to DIN 1835B/6359HB.
- Technical Design:** Runout of outer taper to $D1 \leq 0,003$ mm. Tolerance of bore H4 (more accurate as DIN).
- Includes:** Clamping screw, from $\varnothing 25$ with 2 clamping screws.
- Accessories:** See page 188.

FINE BALANCED
G 2,5 at 25.000^{min}-1 or max.
residual imbalance ≤ 1 gmm

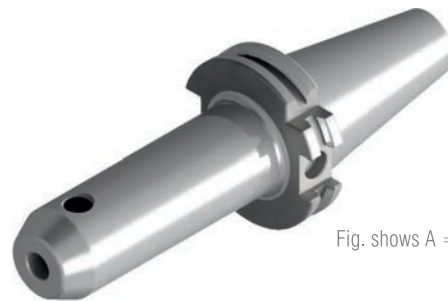
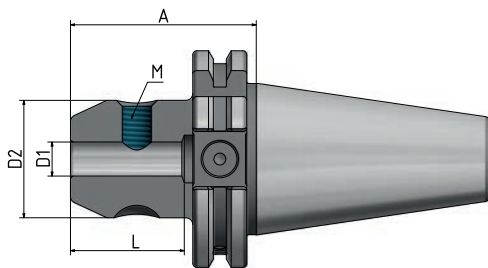

Fig. shows A = 160



Fig. shows $\varnothing 25$ with 2 clamping screws

Order No.	SK	D1	A	D2	L	M	Version
714004-01	40	6	50	25	35	M6	Short
714004-02	40	8	50	28	35	M8	Short
714004-03	40	10	50	35	41	M10	Short
714004-04	40	12	50	42	48	M12	Short
714004-05	40	14	50	44	48	M12	Short
714004-06	40	16	63	48	51	M14	Short
714004-07	40	18	63	48	51	M14	Short
714004-08	40	20	63	52	53	M16	Short
714004-09	40	25	100	65	60	M18x2	Short
714004-10	40	32	100	72	64	M20x2	Short
714004-31	40	6	100	25	35	M6	Long
714004-32	40	8	100	28	35	M8	Long
714004-33	40	10	100	35	41	M10	Long
714004-34	40	12	100	42	48	M12	Long
714004-35	40	14	100	44	48	M12	Long
714004-36	40	16	100	48	51	M14	Long
714004-38	40	20	100	52	53	M16	Long
714004-61	40	6	160	25	35	M6	Extra long
714004-62	40	8	160	28	35	M8	Extra long
714004-63	40	10	160	35	41	M10	Extra long
714004-64	40	12	160	42	48	M12	Extra long
714004-65	40	14	160	44	48	M12	Extra long
714004-66	40	16	160	48	51	M14	Extra long
714004-68	40	20	160	52	53	M16	Extra long

SK 40 ISO 7388-1 Form AD/AF

Endmill holder Weldon „Cool Tool“

- Application:** Particularly suitable for tools without internal coolant, and for machining at difficult positions with bad chip removal.
- Technical Design:** Two holes in the toolholder lead the coolant directly to the cutting edge.
Runout of outer taper to $D1 \leq 0,003$ mm.
Tolerance of bore H4 (more accurate as DIN).
- Includes:** Clamping screw (from $\varnothing 25$ with 2 clamping screws) and 2 x M3-screws to plug the coolant holes if needed.
- Accessories:** See page 188.

FINE BALANCED
G 2,5 at 25.000^{min}-1 or max.
residual imbalance ≤ 1 gmm

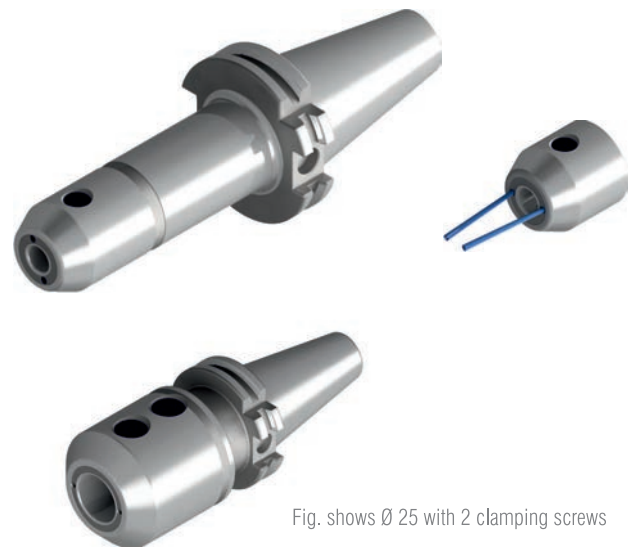
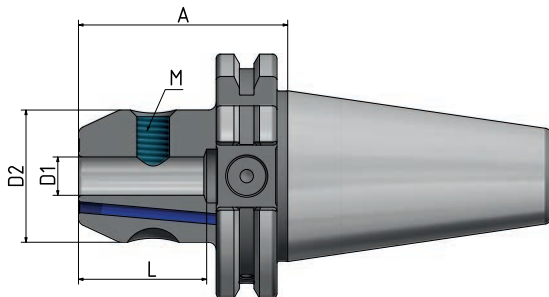

Fig. shows $\varnothing 25$ with 2 clamping screws

Order No.	SK	D1	A	D2	L	M	Version
7140041-01	40	6	50	25	35	M6	Short
7140041-02	40	8	50	28	35	M8	Short
7140041-03	40	10	50	35	41	M10	Short
7140041-04	40	12	50	42	48	M12	Short
7140041-05	40	14	50	44	48	M12	Short
7140041-06	40	16	63	48	51	M14	Short
7140041-08	40	20	63	52	53	M16	Short
7140041-09	40	25	100	65	60	M18x2	Short
7140041-10	40	32	100	72	64	M20x2	Short
7140041-31	40	6	100	25	35	M6	Long
7140041-32	40	8	100	28	35	M8	Long
7140041-33	40	10	100	35	41	M10	Long
7140041-34	40	12	100	42	48	M12	Long
7140041-36	40	16	100	48	51	M14	Long
7140041-38	40	20	100	52	53	M16	Long

Order No.	SK	D1	A	D2	L	M	Version
7140041-51	40	6	130	25	35	M6	Long
7140041-52	40	8	130	28	35	M8	Long
7140041-53	40	10	130	35	41	M10	Long
7140041-54	40	12	130	42	48	M12	Long
7140041-55	40	14	130	44	48	M12	Long
7140041-56	40	16	130	48	51	M14	Long
7140041-57	40	18	130	50	51	M14	Long
7140041-58	40	20	130	52	53	M16	Long
7140041-59	40	25	130	65	60	M18x2	Long
7140041-60	40	32	130	72	64	M20x2	Long

Endmill holder Weldon with 4 x „Cool Tool“ – Corrosion resistant

Application: Particularly suitable for tools without internal coolant, and for machining at difficult positions with bad chip removal.

Technical Design: The entire front area of the tool holder is corrosion resistant.
Runout of outer taper to inner taper $\leq 0,003$ mm.
Tolerance of bore H4 (more accurate as DIN).
Four holes in the toolholder lead the coolant directly to the cutting edge.

Includes: Clamping screw and 4 x M3-screws to plug the coolant holes if needed.

Accessories: See page 188.

FINE BALANCED
G 2,5 at 25.000^{min}-1 or max.
residual imbalance ≤ 1 gmm

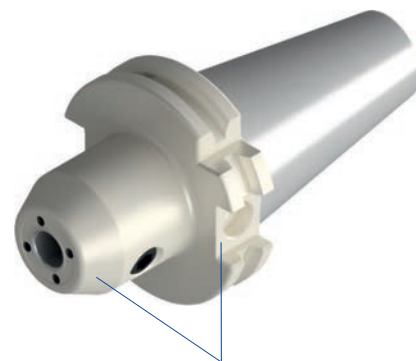
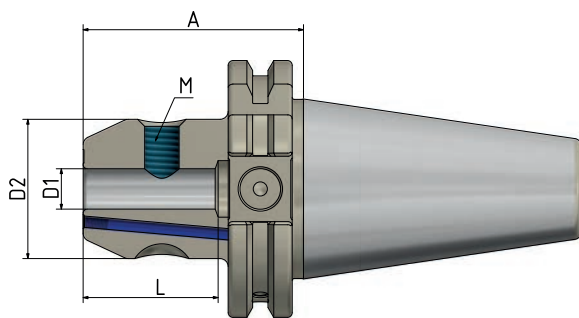

Corrosion resistant



4-fold Cool Tool

Order No.	SK	D1	A	D2	L	M	Version
7140048-018	40	6	50	25	35	M6	Short
7140048-028	40	8	50	28	35	M8	Short
7140048-038	40	10	50	35	41	M10	Short
7140048-048	40	12	50	42	48	M12	Short
7140048-068	40	16	63	48	51	M12	Short
7140048-088	40	20	63	52	53	M14	Short

SK 40 ISO 7388-1 Form AD/AF

Endmill holder Weldon – slim, long version

Application: For clamping tools with cylindrical shank according to DIN 1835B/6359HB and DIN 1835E/6359HE.

Technical Design: Runout of outer taper to inner taper $\leq 0,003$ mm.
Tolerance of bore H4 (more accurate as DIN).

Includes: Special clamping screw (with ball head) and set screw (for internal cooling).

Accessories: See page 167.

FINE BALANCED
G 6,3 at $8.000^{\text{min-1}}$

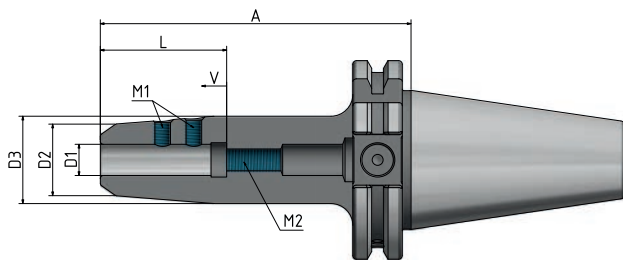

Order No.	SK	D1	A	D2	D3	L	M1	M2	Version
714027-01	40	6	100	13	24	36,5	M6	M5	Long
714027-03	40	8	100	15	26	36,5	M6	M6	Long
714027-05	40	10	100	16	28	40,5	M6	M8x1	Long
714027-07	40	12	100	17	29	45,5	M6	M10x1	Long

Shrink fit holder 4,5°

Application: For clamping tools with cylindrical shank of solid carbide or HSS, tol. h6.

Technical Design: Made of special heat resistant steel. Suitable for inductive shrinking unit. With four additional threads for supplementary fine balancing. Runout of outer taper to $D1 \leq 0,003$ mm.

Includes: Set screw.

Accessories: See page 188.

FINE BALANCED
G 2,5 at 25.000^{min}-1 or max.
residual imbalance ≤ 1 gmm

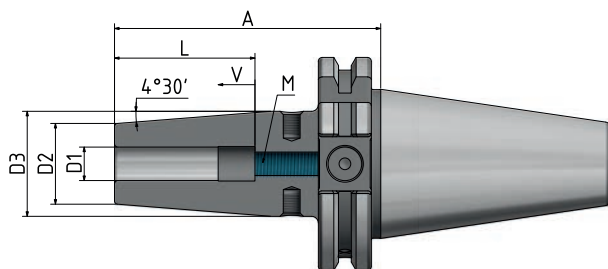

Fig. shows A = 130

Order No.	SK	D1	A	D2	D3	L	V	M	Version
714021-13	40	3	80	12	17	-	-	-	Short
714021-14	40	4	80	12	17	-	-	-	Short
714021-15	40	5	80	12	17	-	-	-	Short
714021-01	40	6	80	21	27	37	10	M5	Short
714021-02	40	8	80	21	27	37	10	M6	Short
714021-03	40	10	80	24	32	42	10	M8x1	Short
714021-04	40	12	80	24	32	48	10	M10x1	Short
714021-05	40	14	80	27	34	48	10	M10x1	Short
714021-06	40	16	80	27	34	51	10	M12x1	Short
714021-07	40	18	80	33	42	51	10	M12x1	Short
714021-08	40	20	80	33	42	53	10	M16x1	Short
714021-09	40	25	100	44	53	59	10	M16x1	Short
714021-10	40	32	100	44	53	63	10	M16x1	Short

Shrink fit holder extra short, please see p. 99, shrink fit holder „Cool Tool“.

SK 40 ISO 7388-1
Form AD/AF

Shrink fit holder 4,5° (Continuation)

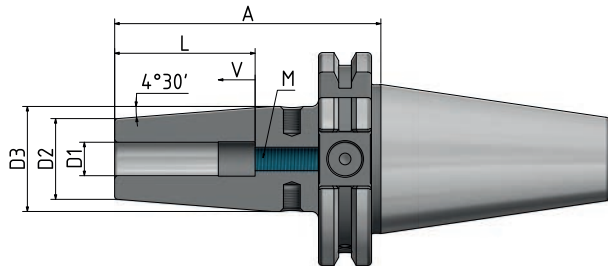

Fig. shows A = 130

Order No.	SK	D1	A	D2	D3	L	V	M	Version
714021-31	40	6	120	21	27	37	10	M5	Long
714021-32	40	8	120	21	27	37	10	M6	Long
714021-33	40	10	120	24	32	42	10	M8x1	Long
714021-34	40	12	120	24	32	48	10	M10x1	Long
714021-35	40	14	120	27	34	48	10	M10x1	Long
714021-36	40	16	120	27	34	51	10	M12x1	Long
714021-37	40	18	120	33	42	51	10	M12x1	Long
714021-38	40	20	120	33	42	53	10	M16x1	Long
714021-39	40	25	120	44	53	59	10	M16x1	Long
714021-513	40	3	130	12	17	-	-	-	Long
714021-514	40	4	130	12	17	-	-	-	Long
714021-515	40	5	130	12	17	-	-	-	Long
714021-51	40	6	130	21	27	37	10	M5	Long
714021-52	40	8	130	21	27	37	10	M6	Long
714021-53	40	10	130	24	32	42	10	M8x1	Long
714021-54	40	12	130	24	32	48	10	M10x1	Long
714021-55	40	14	130	27	34	48	10	M10x1	Long
714021-56	40	16	130	27	34	51	10	M12x1	Long
714021-57	40	18	130	33	42	51	10	M12x1	Long
714021-58	40	20	130	33	42	53	10	M16x1	Long
714021-59	40	25	130	44	53	59	10	M16x1	Long
714021-60	40	32	130	44	53	63	10	M16x1	Long

Shrink fit holder 4,5° (Continuation)

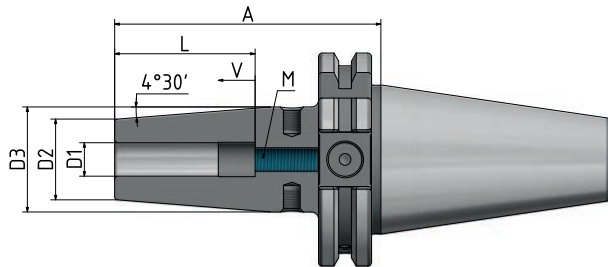

Fig. shows A = 130

Order No.	SK	D1	A	D2	D3	L	V	M	Version
714021-61	40	6	160	21	27	37	10	M5	Extra long
714021-62	40	8	160	21	27	37	10	M6	Extra long
714021-63	40	10	160	24	32	42	10	M8x1	Extra long
714021-64	40	12	160	24	32	48	10	M10x1	Extra long
714021-65	40	14	160	27	34	48	10	M10x1	Extra long
714021-66	40	16	160	27	34	51	10	M12x1	Extra long
714021-67	40	18	160	33	42	51	10	M12x1	Extra long
714021-68	40	20	160	33	42	53	10	M16x1	Extra long
714021-69	40	25	160	44	53	59	10	M16x1	Extra long
714021-81	40	6	200	21	27	37	10	M5	Extra long
714021-82	40	8	200	21	27	37	10	M6	Extra long
714021-83	40	10	200	24	32	42	10	M8x1	Extra long
714021-84	40	12	200	24	32	48	10	M10x1	Extra long
714021-85	40	14	200	27	34	48	10	M10x1	Extra long
714021-86	40	16	200	27	34	51	10	M12x1	Extra long
714021-87	40	18	200	33	42	51	10	M12x1	Extra long
714021-88	40	20	200	33	42	53	10	M16x1	Extra long
714021-89	40	25	200	44	53	59	10	M16x1	Extra long

SK 40 ISO 7388-1 Form AD/AF

Shrink fit holder 4,5° „Cool Tool“

Application: Particularly suitable for tools without internal coolant, and for machining at difficult positions with bad chip removal.

Technical Design: Made of special heat resistant steel. Suitable for inductive shrinking unit. With four additional threads for supplementary fine balancing. Runout of outer taper to $D1 \leq 0,003$ mm. With four additional threads for supplementary fine balancing. Two holes in the toolholder lead the coolant directly to the cutting edge.

Includes: Set screw and 2 x M3-screws to plug the coolant holes if needed.

Accessories: See page 188.

FINE BALANCED
G 2,5 at 25.000^{min-1} or max.
residual imbalance ≤ 1 gmm

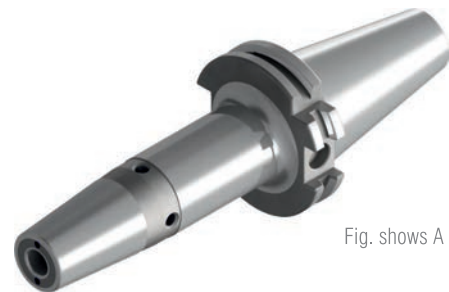
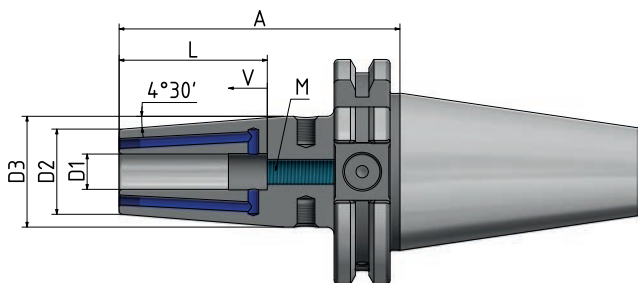

Fig. shows A = 130

Order No.	SK	D1	A	D2	D3	L	V	M	Version
7140219-03*	40	10	65	26	-	42	-	-	Extra short
7140219-04*	40	12	65	26	-	48	-	-	Extra short
7140219-06*	40	16	65	29	-	51	-	-	Extra short
7140219-08*	40	20	65	35	-	53	-	-	Extra short
7140219-09*	40	25	75	45	-	59	-	-	Extra short
714021-139**	40	3	80	12	17	42	-	-	Short
714021-149**	40	4	80	12	17	48	-	-	Short
714021-159**	40	5	80	12	17	51	-	-	Short
714021-019	40	6	80	21	27	37	10	M5	Short
714021-029	40	8	80	21	27	37	10	M6	Short
714021-039	40	10	80	24	32	42	10	M8X1	Short
714021-049	40	12	80	24	32	48	10	M10X1	Short
714021-059	40	14	80	27	34	48	10	M10X1	Short
714021-069	40	16	80	27	34	51	10	M12X1	Short
714021-079	40	18	80	33	42	51	10	M12X1	Short
714021-089	40	20	80	33	42	53	10	M16X1	Short
714021-099	40	25	100	44	53	59	10	M16X1	Short

* Without balancing thread.

** Cool Tool holes cannot be plugged.



Shrink fit holder 4,5° „Cool Tool“ (Continuation)

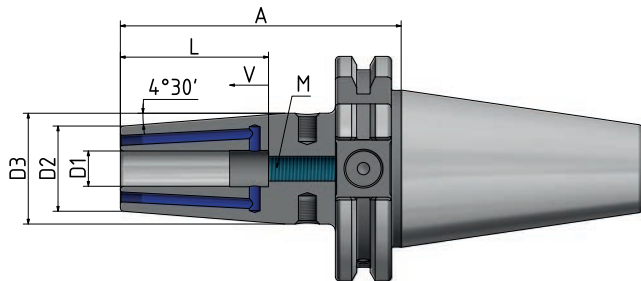

Fig. shows A = 130



Order No.	SK	D1	A	D2	D3	L	V	M	Version
714021-319	40	6	120	21	27	37	10	M5	Long
714021-329	40	8	120	21	27	37	10	M6	Long
714021-339	40	10	120	24	32	42	10	M8X1	Long
714021-349	40	12	120	24	32	48	10	M10X1	Long
714021-359	40	14	120	27	34	48	10	M10X1	Long
714021-369	40	16	120	27	34	51	10	M12X1	Long
714021-379	40	18	120	33	42	51	10	M12X1	Long
714021-389	40	20	120	33	42	53	10	M16X1	Long
714021-5139*	40	3	130	12	17	-	-	-	Long
714021-5149*	40	4	130	12	17	-	-	-	Long
714021-5159*	40	5	130	12	17	-	-	-	Long
714021-519	40	6	130	21	27	37	10	M5	Long
714021-529	40	8	130	21	27	37	10	M6	Long
714021-539	40	10	130	24	32	42	10	M8X1	Long
714021-549	40	12	130	24	32	48	10	M10X1	Long
714021-559	40	14	130	27	34	48	10	M10X1	Long
714021-569	40	16	130	27	34	51	10	M12X1	Long
714021-579	40	18	130	33	42	51	10	M12X1	Long
714021-589	40	20	130	33	42	53	10	M16X1	Long
714021-599	40	25	130	44	53	59	10	M16X1	Long
714021-609	40	32	130	44	53	63	10	M16X1	Long
714021-619	40	6	160	21	27	37	10	M5	Extra long
714021-629	40	8	160	21	27	37	10	M6	Extra long
714021-639	40	10	160	24	32	42	10	M8X1	Extra long
714021-649	40	12	160	24	32	48	10	M10X1	Extra long
714021-669	40	16	160	27	34	51	10	M10X1	Extra long
714021-689	40	20	160	33	42	53	10	M12X1	Extra long

* Cool Tool holes cannot be plugged.

SK 40 ISO 7388-1 Form AD/AF

Shrink fit holder 4,5°, slim / Version „Cool Tool“

Application: For clamping tools with cylindrical shank of solid carbide or HSS, tol. h6.

Technical Design: Made of special heat resistant steel. Suitable for inductive shrinking unit. With four additional threads for supplementary fine balancing. Runout of outer taper to $D1 \leq 0,003$ mm.

Includes: Set screw.

Accessories: See page 188.

FINE BALANCED
G 2,5 at 25.000^{min-1} or max.
residual imbalance ≤ 1 gmm

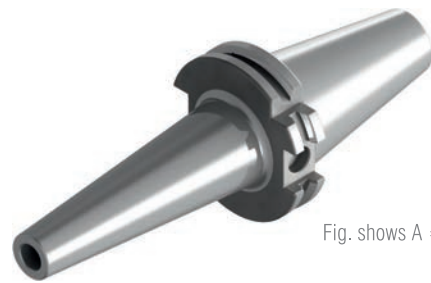
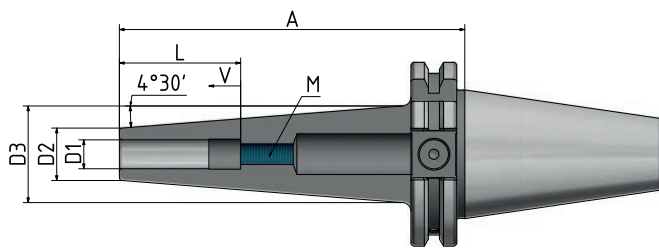

Fig. shows A = 120

Order No.	SK	D1	A	D2	D3	L	V	M	Version
714021-413*	40	3	120	9	25	-	-	-	Long
714021-414*	40	4	120	9	25	-	-	-	Long
714021-415*	40	5	120	9	25	-	-	-	Long
714021-41*	40	6	120	15	30	37	10	M5	Long
714021-42*	40	8	120	15	30	37	10	M6	Long
714021-43*	40	10	120	18	32	42	10	M8x1	Long
714021-44*	40	12	120	18	32	48	10	M10x1	Long

* Without additional balancing thread.

Version „Cool Tool“:

Order No.	SK	D1	A	D2	D3	L	V	M	Version
7140219-41**	40	6	120	15	31	37	10	M5	Long
7140219-42**	40	8	120	16	32	37	10	M6	Long
7140219-43**	40	10	120	18	34	42	10	M8x1	Long
7140219-44**	40	12	120	20	36	48	10	M10x1	Long

* Cool Tool holes cannot be plugged.

** Without additional balancing thread.



Shrink fit holder with 4 x „Cool Tool“ – Corrosion resistant

Application: Particularly suitable for tools without internal coolant, and for Machining at difficult positions with bad chip removal.

Technical Design: Made of special heat resistant steel. Suitable for inductive shrinking unit. With four additional threads for supplementary fine balancing. Runout of outer taper to D1 \leq 0,003 mm. The entire front area of the tool holder is corrosion resistant. Four holes in the toolholder lead the coolant directly to the cutting edge.

Includes: Set screw and 4 x M3-screws to plug the coolant holes if needed.

Accessories: See page 188.

FINE BALANCED
G 2,5 at 25.000^{min}-1 or max.
residual imbalance \leq 1 gmm

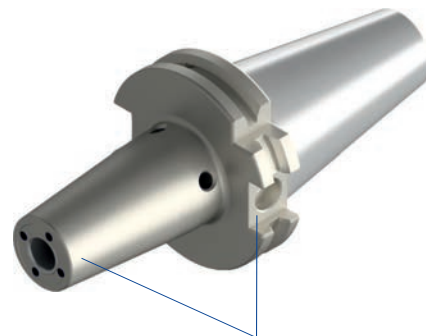
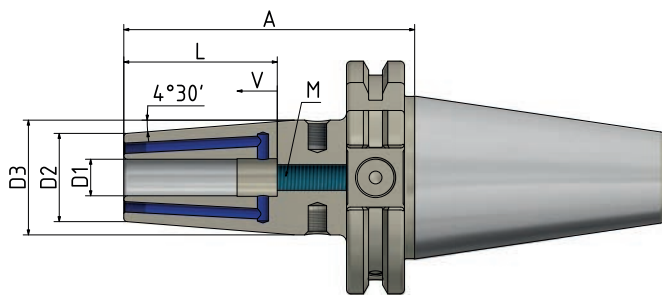

Corrosion resistant

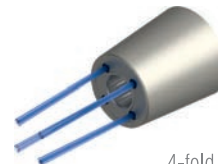

4-fold Cool Tool

Order No.	SK	D1	A	D2	D3	L	V	M	Version
714048-018	40	6	80	21	27	37	10	M5	Short
714048-028	40	8	80	21	27	37	10	M6	Short
714048-038	40	10	80	24	32	42	10	M8x1	Short
714048-048	40	12	80	24	32	48	10	M10x1	Short
714048-068	40	16	80	27	34	51	10	M12x1	Short
714048-088	40	20	80	33	42	53	10	M16x1	Short
714048-318	40	6	120	21	27	37	10	M5	Long
714048-328	40	8	120	21	27	37	10	M6	Long
714048-338	40	10	120	24	32	42	10	M8x1	Long
714048-348	40	12	120	24	32	48	10	M10x1	Long
714048-368	40	16	120	27	34	51	10	M12x1	Long
714048-388	40	20	120	33	42	53	10	M16x1	Long

SK 40 ISO 7388-1 Form AD/AF

Shrink fit holder 3 Grad

Application: For clamping tools with cylindrical shank of solid carbide or HSS, tol. h6.

Technical Design: Made of special heat resistant steel. Suitable for inductive shrinking unit. Runout of outer taper to $D1 \leq 0,003$ mm.

FINE BALANCED
G 2,5 at 25.000^{min}-1 or max.
residual imbalance ≤ 1 gmm

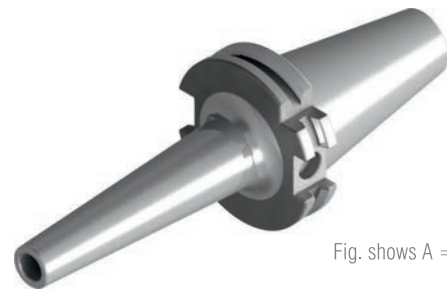
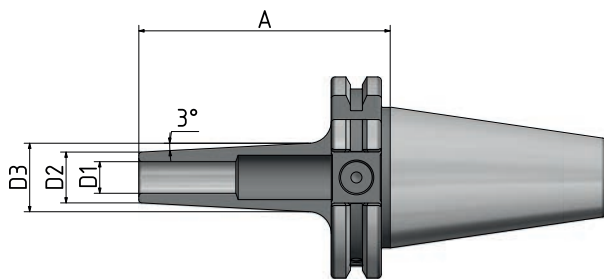

Fig. shows A = 120

Order No.	SK	D1	A	D2	D3	Version
714051-13	40	3	80	9	14	Short
714051-14	40	4	80	10	15	Short
714051-15	40	5	80	11	16	Short
714051-01	40	6	80	12	19	Short
714051-02	40	8	80	14	21	Short
714051-03	40	10	80	16	23	Short
714051-04	40	12	80	18	25	Short
714051-313	40	3	120	9	18	Long
714051-314	40	4	120	10	19	Long
714051-315	40	5	120	11	20	Long
714051-31	40	6	120	12	23	Long
714051-32	40	8	120	14	25	Long
714051-33	40	10	120	16	27	Long
714051-34	40	12	120	18	29	Long

Thread shank adapter – Conical form

Application: For clamping threaded shank end mill bodies.

Technical Design: Runout of outer taper to D1 \leq 0,005 mm.

FINE BALANCED
G 2,5 at 25.000^{min}-1 or max.
residual imbalance \leq 1 gmm

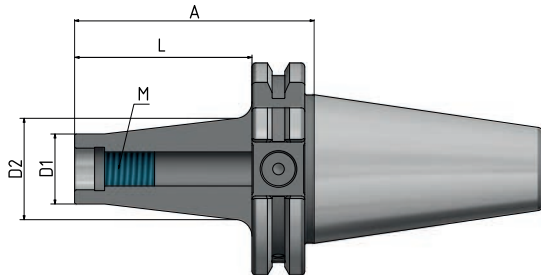

Order No.	SK	M	A	L	D1	D2	Version
714008-01	40	M8	44,1	25	13	15	Conical
714008-02	40	M8	69,1	50	13	23	Conical
714008-03	40	M8	94,1	75	13	25	Conical
714010-01	40	M10	44,1	25	18	23	Conical
714010-02	40	M10	69,1	50	18	25	Conical
714010-03	40	M10	94,1	75	18	30	Conical
714010-04	40	M10	119,1	100	18	35	Conical
714010-06	40	M10	169,1	150	18	45	Conical
714012-01	40	M12	44,1	25	21	24	Conical
714012-02	40	M12	69,1	50	21	30	Conical
714012-03	40	M12	94,1	75	21	35	Conical
714012-04	40	M12	119,1	100	21	38	Conical
714012-06	40	M12	169,1	150	21	48	Conical
714016-01	40	M16	44,1	25	29	29	Conical
714016-02	40	M16	69,1	50	29	34	Conical
714016-03	40	M16	94,1	75	29	35	Conical
714016-04	40	M16	119,1	100	29	40	Conical
714016-06	40	M16	169,1	150	29	48	Conical

SK 40 ISO 7388-1 Form AD/AF

Thread shank adapter – Cylindrical form

Application: For clamping threaded shank end mill bodies.

Technical Design: Runout of outer taper to $D1 \leq 0,005$ mm.

FINE BALANCED
G 2,5 at 25.000^{min}-1 or max.
residual imbalance ≤ 1 gmm

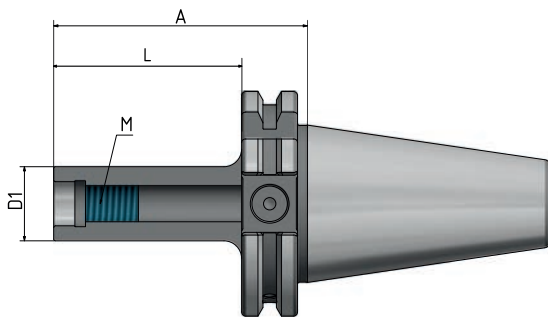

Order No.	SK	M	A	L	D1	Version
7140057-01	40	M5	44,1	25	10	Cylindrical
7140067-01	40	M6	44,1	25	10	Cylindrical
7140087-01	40	M8	44,1	25	13	Cylindrical
7140087-02	40	M8	69,1	50	13	Cylindrical
7140087-03	40	M8	94,1	75	13	Cylindrical
7140107-01	40	M10	44,1	25	18	Cylindrical
7140107-02	40	M10	69,1	50	18	Cylindrical
7140107-03	40	M10	94,1	75	18	Cylindrical
7140107-04	40	M10	119,1	100	18	Cylindrical
7140107-05	40	M10	144,1	125	18	Cylindrical
7140107-06	40	M10	169,1	150	18	Cylindrical
7140127-01	40	M12	44,1	25	21	Cylindrical
7140127-02	40	M12	69,1	50	21	Cylindrical
7140127-03	40	M12	94,1	75	21	Cylindrical
7140127-04	40	M12	119,1	100	21	Cylindrical
7140127-05	40	M12	144,1	125	21	Cylindrical
7140127-06	40	M12	169,1	150	21	Cylindrical
7140167-01	40	M16	44,1	25	29	Cylindrical
7140167-02	40	M16	69,1	50	29	Cylindrical
7140167-03	40	M16	94,1	75	29	Cylindrical
7140167-04	40	M16	119,1	100	29	Cylindrical
7140167-06	40	M16	169,1	150	29	Cylindrical

Shell mill holder „Cool Tool“

Application: For adapting shell mills with transverse slot, with coolant mandrel on the cutting edge.

Technical Design: With extended flange.
Runout of outer taper to $D1 \leq 0,006$ mm.

Includes: Clamping screw and drive keys.

Accessories: See page 189.

FINE BALANCED
G 2,5 at 25.000^{min}-1 or max.
residual imbalance ≤ 1 gmm

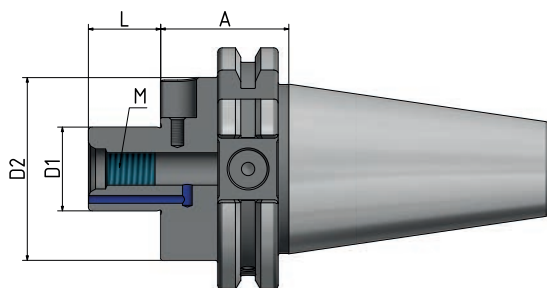

Fig. shows A = 160



Order No.	SK	D1	A	D2	L1	M	Version
7140051-01	40	16	35	38	17	M8	Short
7140051-02	40	22	35	48	19	M10	Short
7140051-03	40	27	35	50	21	M12	Short
7140051-04	40	32	50	78	24	M16	Short
7140051-05	40	40	50	89	27	M20	Short
7140051-21	40	16	60	38	17	M8	Short
7140051-22	40	22	60	48	19	M10	Short
7140051-23	40	27	60	50	21	M12	Short
7140051-24	40	32	70	78	24	M16	Short
7140051-25	40	40	70	89	27	M20	Short
7140051-31	40	16	100	38	17	M8	Long
7140051-32	40	22	100	48	19	M10	Long
7140051-33	40	27	100	50	21	M12	Long
7140051-34	40	32	100	78	24	M16	Long
7140051-62	40	22	160	48	19	M10	Extra long
7140051-63	40	27	160	50	21	M12	Extra long
7140051-64	40	32	160	78	24	M16	Extra long

SK 40 ISO 7388-1 Form AD/AF

Combi shell mill holder

- Application:** For adapting shell mills with transverse and longitudinal groove.
- Technical Design:** Runout of outer taper to $D1 \leq 0,006$ mm.
- Includes:** Clamping screw, drive key and adjusting spring.
- Accessories:** See page 190.

 **FINE BALANCED**
G 2,5 at 25.000^{min}-1 or max.
residual imbalance ≤ 1 gmm

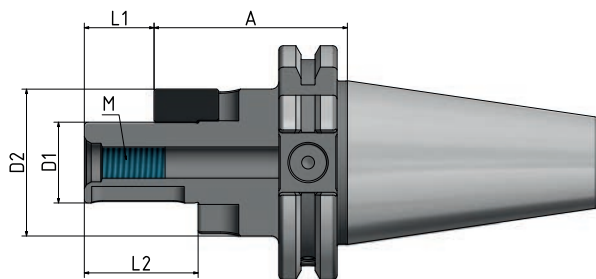

Fig. shows A = 160

Order No.	SK	D1	A	D2	L1	L2	M	Version
714006-01	40	16	55	32	17	27	M8	Short
714006-02	40	22	55	40	19	31	M10	Short
714006-03	40	27	55	48	21	33	M12	Short
714006-04	40	32	60	58	24	38	M16	Short
714006-31	40	16	100	32	17	27	M8	Long
714006-32	40	22	100	40	19	31	M10	Long
714006-33	40	27	100	48	21	33	M12	Long
714006-34	40	32	100	58	24	38	M16	Long
714006-61	40	16	160	32	17	27	M8	Extra long
714006-62	40	22	160	40	19	31	M10	Extra long
714006-63	40	27	160	48	21	33	M12	Extra long
714006-64	40	32	160	58	24	38	M16	Extra long

Short drill chuck

Application: For clamping tools with cylindrical shank.
Also suitable for tools with internal coolant.

Includes: Wrench

 **FINE BALANCED**
G 6,3 at 18.000^{min}-1

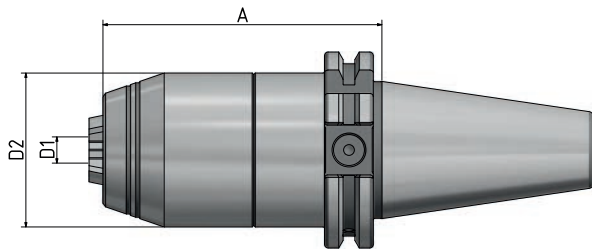

Order No.	SK	Clamping range D1	A	D2
714095-52	40	1-16	80	50

SK 50 ISO 7388-1 Form AD/AF

HPC – Precision ER collet chuck HAWK EYE®

Application: For clamping tools with cylindrical shank in collets ER.

Technical Design: Due to high precision taper tolerances of the ER-Inner taper and the collet taper max. runout of $\leq 5 \mu$ at $2,5 \times D$, subject the usage of our HP 2μ ER collets. The deep fit of the collet inside the chuck combined with a surface treated clamping nut achieves more than double clamping force compared to standard ER collet chuck. HAWK EYE® has an enforced body for max. radial rigidity. The patented special design of HAWK EYE® chuck is only suitable to clamp nominal diameters of the collet used.

Includes: Special clamping nut.

Accessories: See page 183.

FINE BALANCED
G 2,5 at 25.000^{min-1} or max.
residual imbalance ≤ 1 gmm

SK 50 ISO 7388-1

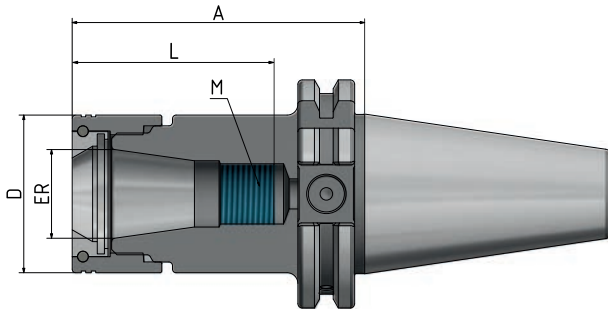
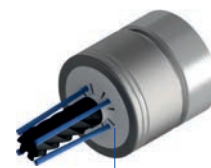

Fig. shows A = 160

Order No.	SK	ER	D	A	Clamping range	L	M	Version
715032-04	50	25	44	70	1–16	70	M18x1,5	Short
715032-05	50	32	52	70	2–20	80	M24x1,5	Short
715032-06	50	40	62	70	4–26	92	M28x1,5	Short
715032-34	50	25	44	100	1–16	100	M18x1,5	Long
715032-35	50	32	52	100	2–20	78	M24x1,5	Long
715032-36	50	40	62	100	4–26	92	M28x1,5	Long
715032-54	50	25	44	130	1–16	130	M18x1,5	Long
715032-55	50	32	52	130	2–20	78	M24x1,5	Long
715032-56	50	40	62	130	4–26	92	M28x1,5	Long
715032-64	50	25	44	160	1–16	160	M18,1,5	Extra long
715032-65	50	32	52	160	2–20	78	M24x1,5	Extra long
715032-66	50	40	62	160	4–26	92	M28x1,5	Extra long



Sealed versions
see pages 186, 187.

ER-Collet chuck

Application: For clamping tools with cylindrical shank in collets ER.

Technical Design: Runout of outer taper to inner taper $\leq 0,003$ mm.
Due to adjusted taper tolerances of the ER-Inner taper and the collet taper max. runout of $\leq 8 \mu$ at $2,5 \times D$.

Includes: Clamping nut.

Accessories: See page 183.

FINE BALANCED
G 2,5 at 25.000^{min-1} or max.
residual imbalance ≤ 1 gmm

SK 50 ISO 7388-1

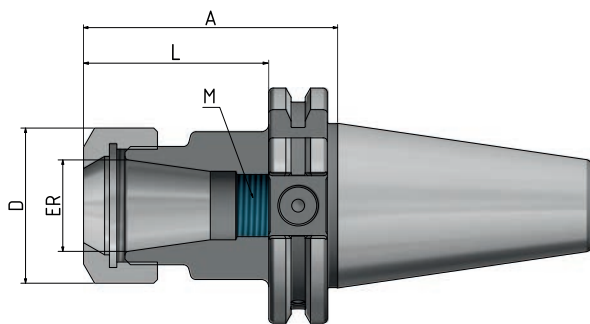

Fig. shows A = 160

Order No.	SK	ER	Clamping range		A	D	L	M	Version
			min	max					
715002-01	50	16	1-10		70	28	46	M11x1	Short
715002-02	50	25	1-16		70	42	46	M18x1,5	Short
715002-03	50	32	2-20		70	50	82	M24x1,5	Short
715002-04	50	40	4-26		70	63	96	M28x1,5	Short
715002-31	50	16	1-10		100	28	80	M11x1	Long
715002-32	50	25	1-16		100	42	69	M18x1,5	Long
715002-33	50	32	2-20		100	50	82	M24x1,5	Long
715002-34	50	40	4-26		100	63	96	M28x1,5	Long
715002-61	50	16	1-10		160	28	140	M11x1	Extra long
715002-62	50	25	1-16		160	42	140	M18x1,5	Extra long
715002-63	50	32	2-20		160	50	160	M24x1,5	Extra long
715002-64	50	40	4-26		160	63	96	M28x1,5	Extra long



Sealed versions
see pages 186, 187.

SK 50 ISO 7388-1 Form AD/AF

ER-Collet chuck „Mini“

Application: For clamping tools with cylindrical shank in collets ER.

Technical Design: Runout of outer taper to inner taper $\leq 0,003$ mm.
Due to adjusted taper tolerances of the ER-Inner taper and the collet taper max. runout of $\leq 8 \mu$ at $2,5 \times D$.

Includes: Clamping nut.

Accessories: See page 183.

FINE BALANCED
G 2,5 at 25.000^{min}-1 or max.
residual imbalance ≤ 1 gmm

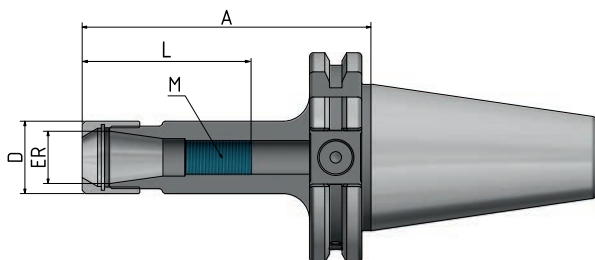

Fig. shows A = 160

Order No.	SK	ER	Clamping range				M	Version
			A	D	L			
715002-41	50	11	1-7	100	16	49	M8x1	Short
715002-43	50	16	1-10	100	22	100	M11x1	Short
715002-45	50	25	1-16	100	35	100	M18x1,5	Short
715002-42	50	11	1-7	160	16	49	M8x1	Extra long
715002-44	50	16	1-10	160	22	160	M11x1	Extra long
715002-46	50	25	1-16	160	35	160	M18x1,5	Extra long

Endmill holder Weldon

- Application:** For clamping tools with cylindrical shank according to DIN 1835B/6359HB.
- Technical Design:** Runout of outer taper to $D1 \leq 0,003$ mm.
Tolerance of bore H4 (more accurate as DIN).
- Includes:** Clamping screw, from $\varnothing 25$ with 2 clamping screws.
- Accessories:** See page 188.

FINE BALANCED
G 2,5 at 25.000^{min}-1 or max.
residual imbalance ≤ 1 gmm

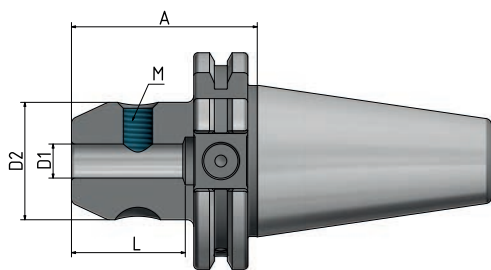

Fig. shows A = 160



Fig. shows $\varnothing 25$ with 2 clamping screws

Order No.	SK	D1	A	D2	L1	M1	Version
715004-01	50	6	63	25	35	M6	Short
715004-02	50	8	63	28	35	M8	Short
715004-03	50	10	63	35	41	M10	Short
715004-04	50	12	63	42	48	M12	Short
715004-05	50	14	63	44	48	M12	Short
715004-06	50	16	63	48	51	M14	Short
715004-08	50	20	63	52	53	M16	Short
715004-09	50	25	80	65	60	M18x2	Short
715004-10	50	32	100	72	64	M20x2	Short
715004-31	50	6	100	25	35	M6	Long
715004-32	50	8	100	28	35	M8	Long
715004-33	50	10	100	35	41	M10	Long
715004-34	50	12	100	42	48	M12	Long
715004-35	50	14	100	44	48	M12	Long
715004-36	50	16	100	48	51	M14	Long
715004-38	50	20	100	52	53	M16	Long
715004-39	50	25	100	65	60	M18x2	Long

Order No.	SK	D1	A	D2	L1	M1	Version
715004-61	50	6	160	25	35	M6	Extra long
715004-62	50	8	160	28	35	M8	Extra long
715004-63	50	10	160	35	41	M10	Extra long
715004-64	50	12	160	42	48	M12	Extra long
715004-65	50	14	160	44	48	M12	Extra long
715004-66	50	16	160	48	51	M14	Extra long
715004-68	50	20	160	52	53	M16	Extra long
715004-69	50	25	160	65	60	M18x2	Extra long
715004-70	50	32	160	72	64	M20x2	Extra long

SK 50 ISO 7388-1 Form AD/AF

Endmill holder Weldon „Cool Tool“

- Application:** Particularly suitable for tools without internal coolant, and for machining at difficult positions with bad chip removal.
- Technical Design:** Two holes in the toolholder lead the coolant directly to the cutting edge. Runout of outer taper to $D1 \leq 0,003$ mm. Tolerance of bore H4 (more accurate as DIN).
- Includes:** Clamping screw (from $\varnothing 25$ with 2 clamping screws) and 2 x M3-screws to plug the coolant holes if needed.
- Accessories:** See page 188.

FINE BALANCED
G 2,5 at 25.000^{min}-1 or max.
residual imbalance ≤ 1 gmm

SK 50 ISO 7388-1

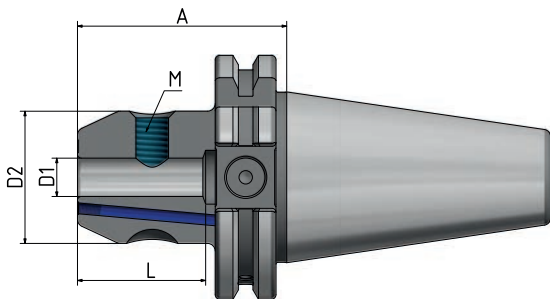

Fig. shows A = 63

Order No.	SK	D1	A	D2	L	M	Version
7150041-01	50	6	63	25	35	M6	Short
7150041-02	50	8	63	28	35	M8	Short
7150041-03	50	10	63	35	41	M10	Short
7150041-04	50	12	63	42	48	M12	Short
7150041-05	50	14	63	44	48	M12	Short
7150041-06	50	16	63	48	51	M14	Short
7150041-07	50	18	63	48	51	M14	Short
7150041-08	50	20	63	52	53	M16	Short
7150041-09	50	25	80	65	60	M18X2	Short
7150041-10	50	32	100	72	64	M20X2	Short



Fig. shows $\varnothing 25$ with 2 clamping screws

Shrink fit holder 4,5°

Application: For clamping tools with cylindrical shank of solid carbide or HSS, tol. h6.

Technical Design: Made of special heat resistant steel. Suitable for inductive shrinking unit. With four additional threads for supplementary fine balancing. Runout of outer taper to $D1 \leq 0,003$ mm.

Includes: Set screw.

Accessories: See page 188.

FINE BALANCED
G 2,5 at 25.000^{min-1} or max.
residual imbalance ≤ 1 gmm

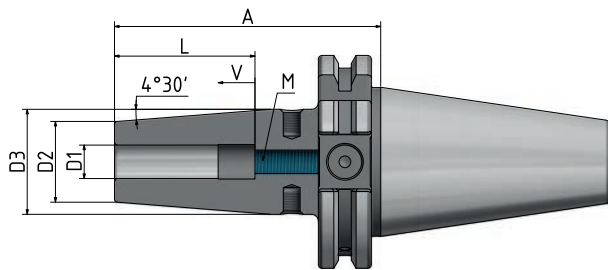

Fig. shows A = 130

Order No.	SK	D1	A	D2	D3	L	V	M	Version
715021-01	50	6	80	21	27	37	10	M5	Short
715021-02	50	8	80	21	27	37	10	M6	Short
715021-03	50	10	80	24	32	42	10	M8x1	Short
715021-04	50	12	80	24	32	48	10	M10x1	Short
715021-05	50	14	80	27	34	48	10	M10x1	Short
715021-06	50	16	80	27	34	51	10	M12x1	Short
715021-07	50	18	80	33	42	51	10	M12x1	Short
715021-08	50	20	80	33	42	53	10	M16x1	Short
715021-09	50	25	100	44	53	59	10	M16x1	Short
715021-10	50	32	100	44	53	63	10	M16x1	Short

SK 50 ISO 7388-1 Form AD/AF

Shrink fit holder 4,5° (Continuation)

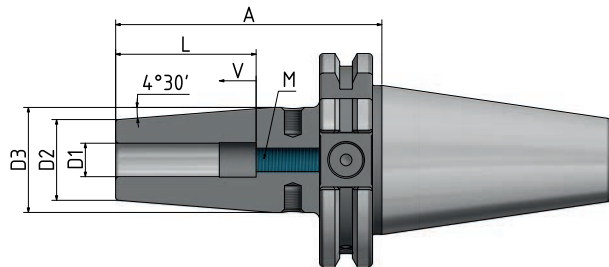

Fig. shows A = 130

Order No.	SK	D1	A	D2	D3	L	V	M	Version
715021-31	50	6	120	21	27	37	10	M5	Long
715021-32	50	8	120	21	27	37	10	M6	Long
715021-33	50	10	120	24	32	42	10	M8x1	Long
715021-34	50	12	120	24	32	48	10	M10x1	Long
715021-35	50	14	120	27	34	48	10	M10x1	Long
715021-36	50	16	120	27	34	51	10	M12x1	Long
715021-37	50	18	120	33	42	51	10	M12x1	Long
715021-38	50	20	120	33	42	53	10	M16x1	Long
715021-39	50	25	120	44	53	59	10	M16x1	Long
715021-40	50	32	120	44	53	63	10	M16x1	Long
715021-51	50	6	130	21	27	37	10	M5	Long
715021-52	50	8	130	21	27	37	10	M6	Long
715021-53	50	10	130	24	32	42	10	M8x1	Long
715021-54	50	12	130	24	32	48	10	M10x1	Long
715021-55	50	14	130	27	34	48	10	M10x1	Long
715021-56	50	16	130	27	34	51	10	M12x1	Long
715021-57	50	18	130	33	42	51	10	M12x1	Long
715021-58	50	20	130	33	42	53	10	M16x1	Long
715021-59	50	25	130	44	53	59	10	M16x1	Long
715021-60	50	32	130	44	53	63	10	M16x1	Long
715021-61	50	6	160	21	27	37	10	M5	Extra long
715021-62	50	8	160	21	27	37	10	M6	Extra long
715021-63	50	10	160	24	32	42	10	M8x1	Extra long
715021-64	50	12	160	24	32	48	10	M10x1	Extra long
715021-65	50	14	160	27	34	48	10	M10x1	Extra long
715021-66	50	16	160	27	34	51	10	M12x1	Extra long
715021-67	50	18	160	33	42	51	10	M12x1	Extra long
715021-68	50	20	160	33	42	53	10	M16x1	Extra long
715021-69	50	25	160	44	53	59	10	M16x1	Extra long
715021-70	50	32	160	44	53	63	10	M16x1	Extra long

SK 50 ISO 7388-1

Shrink fit holder 4,5° (Continuation)

SK 50 ISO 7388-1

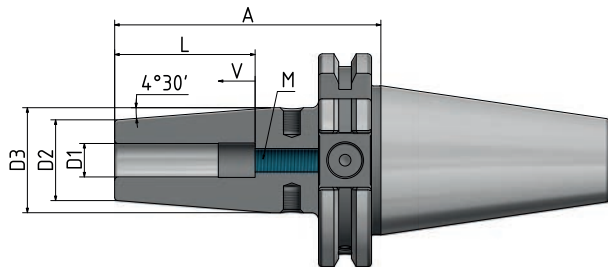

Fig. shows A = 130

Order No.	SK	D1	A	D2	D3	L	V	M	Version
715021-81	50	6	200	21	27	37	10	M5	Extra long
715021-82	50	8	200	21	27	37	10	M6	Extra long
715021-83	50	10	200	24	32	42	10	M8x1	Extra long
715021-84	50	12	200	24	32	48	10	M10x1	Extra long
715021-85	50	14	200	27	34	48	10	M10x1	Extra long
715021-86	50	16	200	27	34	51	10	M12x1	Extra long
715021-87	50	18	200	33	42	51	10	M12x1	Extra long
715021-88	50	20	200	33	42	53	10	M16x1	Extra long
715021-89	50	25	200	44	53	59	10	M16x1	Extra long
715021-90	50	32	200	44	53	63	10	M16x1	Extra long

SK 50 ISO 7388-1 Form AD/AF

Shrink fit holder 4,5° „Cool Tool“

Application: Particularly suitable for tools without internal coolant, and for machining at difficult positions with bad chip removal.

Technical Design: Made of special heat resistant steel. Suitable for inductive shrinking unit. With four additional threads for supplementary fine balancing. Runout of outer taper to $D1 \leq 0,003$ mm. With four additional threads for supplementary fine balancing. Two holes in the toolholder lead the coolant directly to the cutting edge.

Includes: Set screw and 2 x M3-screws to plug the coolant holes if needed.

Accessories: See page 188.

FINE BALANCED
G 2,5 at 25.000^{min}-1 or max.
residual imbalance ≤ 1 gmm

SK 50 ISO 7388-1

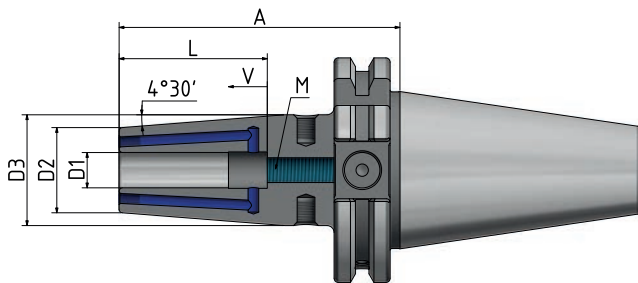

Fig. shows A = 120



Order No.	SK	D1	A	D2	D3	L	V	M	Version
715021-019	50	6	80	21	27	37	10	M5	Short
715021-029	50	8	80	21	27	37	10	M6	Short
715021-039	50	10	80	24	32	42	10	M8x1	Short
715021-049	50	12	80	24	32	48	10	M10x1	Short
715021-059	50	14	80	27	34	48	10	M10x1	Short
715021-069	50	16	80	27	34	51	10	M12x1	Short
715021-079	50	18	80	33	42	51	10	M12x1	Short
715021-089	50	20	80	33	42	53	10	M16x1	Short
715021-099	50	25	100	44	53	59	10	M16x1	Short
715021-109	50	32	100	44	53	63	10	M16x1	Short
715021-319	50	6	120	21	27	37	10	M5	Long
715021-329	50	8	120	21	27	37	10	M6	Long
715021-339	50	10	120	24	32	42	10	M8x1	Long
715021-349	50	12	120	24	32	48	10	M10x1	Long
715021-359	50	14	120	27	34	48	10	M10x1	Long
715021-369	50	16	120	27	34	51	10	M12x1	Long
715021-379	50	18	120	33	42	51	10	M12x1	Long
715021-389	50	20	120	33	42	53	10	M16x1	Long

Shrink fit holder 4,5° „Cool Tool“ (Continuation)

SK 50 ISO 7388-1

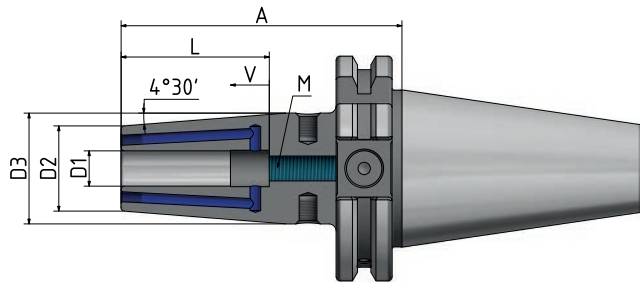

Fig. shows A = 120



Order No.	SK	D1	A	D2	D3	L	V	M	Version
715021-619	50	6	160	21	27	37	10	M5	Extra long
715021-629	50	8	160	21	27	37	10	M6	Extra long
715021-639	50	10	160	24	32	42	10	M8x1	Extra long
715021-649	50	12	160	24	32	48	10	M10x1	Extra long
715021-659	50	14	160	27	34	48	10	M10x1	Extra long
715021-669	50	16	160	27	34	51	10	M12x1	Extra long
715021-679	50	18	160	33	42	51	10	M12x1	Extra long
715021-689	50	20	160	33	42	53	10	M16x1	Extra long

SK 50 ISO 7388-1 Form AD/AF

Shrink fit holder with 4 x „Cool Tool“ – Corrosion resistant

Application: Particularly suitable for tools without internal coolant, and for Machining at difficult positions with bad chip removal.

Technical Design: Made of special heat resistant steel. Suitable for inductive shrinking unit. With four additional threads for supplementary fine balancing. Runout of outer taper to $D1 \leq 0,003$ mm. The entire front area of the tool holder is corrosion resistant. Four holes in the toolholder lead the coolant directly to the cutting edge.

Includes: Set screw and 4 x M3-screws to plug the coolant holes if needed.

Accessories: See page 188.

FINE BALANCED
G 2,5 at 25.000^{min}-1 or max.
residual imbalance ≤ 1 gmm

SK 50 ISO 7388-1

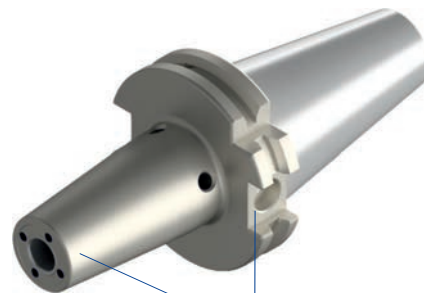
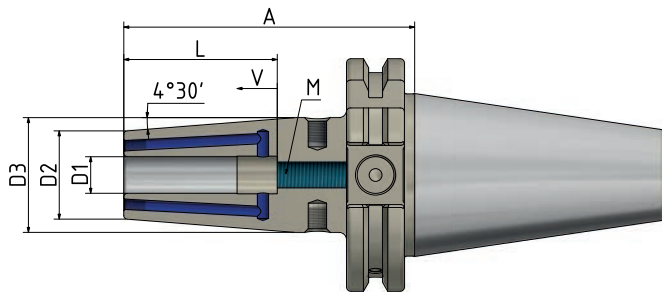

Corrosion resistant



4-fold Cool Tool

Order No.	SK	D1	A	D2	D3	V	L	M	Version
715048-018	50	6	80	21	27	10	37	M5	Short
715048-028	50	8	80	21	27	10	37	M6	Short
715048-038	50	10	80	24	32	10	42	M8x1	Short
715048-048	50	12	80	24	32	10	48	M10x1	Short
715048-068	50	16	80	27	34	10	51	M12x1	Short
715048-088	50	20	80	33	42	10	53	M16x1	Short

Shell mill holder „Cool Tool“

Application: For adapting shell mills with transverse slot, with coolant mandrel on the cutting edge.

Technical Design: With extended flange.
Runout of outer taper to $D1 \leq 0,006$ mm.

Includes: Clamping screw and drive keys.

Accessories: See page 189.

FINE BALANCED
G 2,5 at 25.000^{min}-1 or max.
residual imbalance ≤ 1 gmm

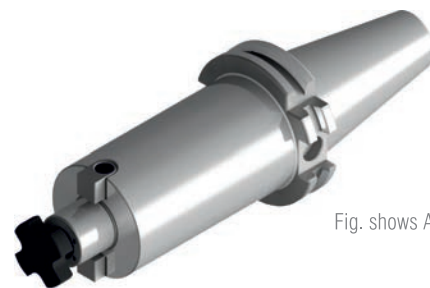
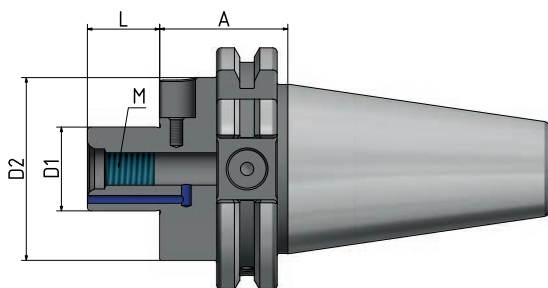

Fig. shows A = 160



Order No.	SK	D1	A	D2	L1	M	Version
7150051-02	50	22	35	48	19	M10	Short
7150051-03	50	27	35	60	21	M12	Short
7150051-04	50	32	35	78	24	M16	Short
7150051-05	50	40	50	89	27	M20	Short
7150051-32	50	22	100	48	19	M10	Long
7150051-33	50	27	100	60	21	M12	Long
7150051-34	50	32	100	78	24	M16	Long
7150051-35	50	40	100	89	27	M20	Long
7150051-621	50	22	160	48	19	M10	Extra long
7150051-631	50	27	160	60	21	M12	Extra long
7150051-641	50	32	160	78	24	M16	Extra long
7150051-651	50	40	160	89	27	M20	Extra long

SK 50 ISO 7388-1 Form AD/AF

Combi shell mill holder

- Application:** For adapting shell mills with transverse and longitudinal groove.
- Technical Design:** Runout of outer taper to $D1 \leq 0,006$ mm.
- Includes:** Clamping screw, drive key and adjusting spring.
- Accessories:** See page 190.

FINE BALANCED
G 2,5 at 25.000^{min}-1 or max.
residual imbalance ≤ 1 gmm

SK 50 ISO 7388-1

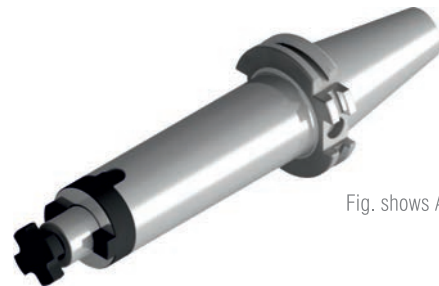
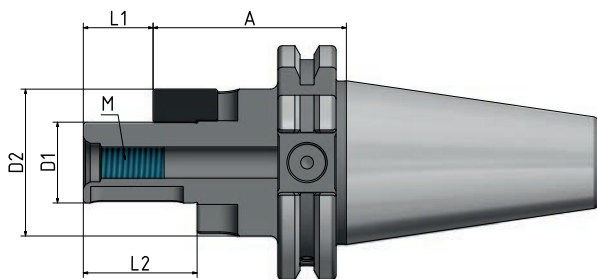

Fig. shows A = 160

Order No.	SK	D1	A	D2	L1	L2	M	Version
715006-02	50	22	55	40	19	31	M10	Short
715006-03	50	27	55	48	21	33	M12	Short
715006-04	50	32	55	58	24	38	M16	Short
715006-05	50	40	55	70	27	41	M20	Short
715006-32	50	22	100	40	19	31	M10	Long
715006-33	50	27	100	48	21	33	M12	Long
715006-34	50	32	100	58	24	38	M16	Long
715006-35	50	40	100	70	27	41	M20	Long
715006-62	50	22	160	40	19	31	M10	Extra long
715006-63	50	27	160	48	21	33	M12	Extra long
715006-64	50	32	160	58	24	38	M16	Extra long
715006-65	50	40	160	70	27	41	M20	Extra long

Short drill chuck

Application: For clamping tools with cylindrical shank.
Also suitable for tools with internal coolant.

Includes: Wrench

 **FINE BALANCED**
G 6,3 at 18.000^{min}-1

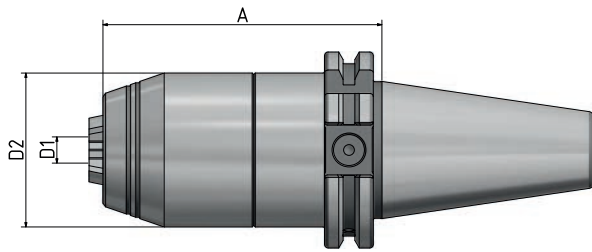

Order No.	SK	Clamping range D1	A	D2
715095-52	50	1-16	80	50

TOOL HOLDER

ISO 7388-2, FORM JD/JF

FORMER MAS-BT, FORM AD/B

BT 30, BT 40 AND BT 50

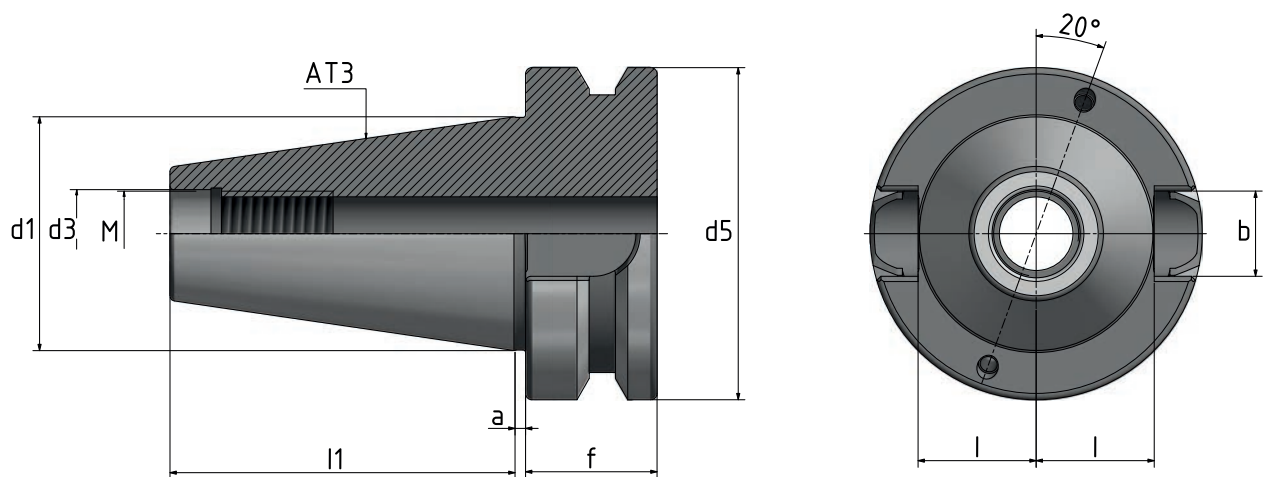

BT	l1	d1	d5	f	a	M	d3	b	l6
30*	48,4	31,75	46	20	2	M12	12,5	16,1	16,3
40	65,4	44,45	63	25	2	M16	17	16,1	22,6
50	101,8	69,85	100	35	3	M24	25	25,7	35,4

*Version JD

HPC – Precision ER collet chuck HAWK EYE® / „Mini“

Application: For clamping tools with cylindrical shank in collets ER.

Technical Design: Due to high precision taper tolerances of the ER-Inner taper and the collet taper max. runout of $\leq 5 \mu$ at $2,5 \times D$, subject the usage of our HP 2μ ER collets. The deep fit of the collet inside the chuck combined with a surface treated clamping nut achieves more than double clamping force compared to standard ER collet chuck. HAWK EYE® has an enforced body for max. radial rigidity. The patented special design of HAWK EYE® chuck is only suitable to clamp nominal diameters of the collet used.

Includes: Special clamping nut.

Accessories: See page 183.

FINE BALANCED
G 2,5 at 25.000^{min-1} or max.
residual imbalance ≤ 1 gmm

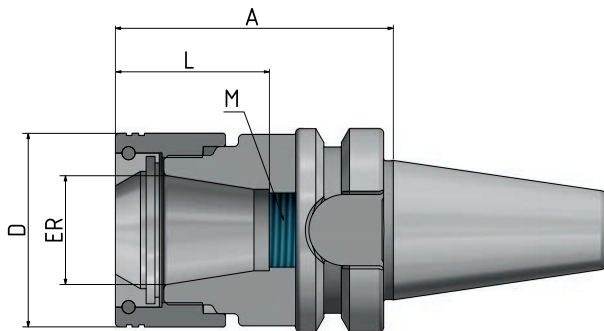

Order No.	BT	ER	D	A	Clamping range	L	M	Version
753032-02	30	16	34	60	1–10	60	M11x1	Extra short
753032-04	30	25	44	60	1–16	69	M18x1,5	Extra short

ER „Mini“

Order No.	BT	ER	D	A	Clamping range	L	M	Version
753034-01	30	11	16	70	1–7	70	M8x1	Short
753034-02	30	16	24	70	1–10	70	M11x1	Short



Sealed versions
see pages 186, 187.

BT 30 ISO 7388-2 Form JD

ER-Collet chuck

Application: For clamping tools with cylindrical shank in collets ER.

Technical Design: Runout of outer taper to inner taper $\leq 0,003$ mm.
Due to adjusted taper tolerances of the ER-Inner taper and the collet taper max. runout of $\leq 8 \mu$ at $2,5 \times D$.

Includes: Clamping nut.

Accessories: See page 183.

FINE BALANCED
G 2,5 at 25.000^{min}-1 or max.
residual imbalance ≤ 1 gmm

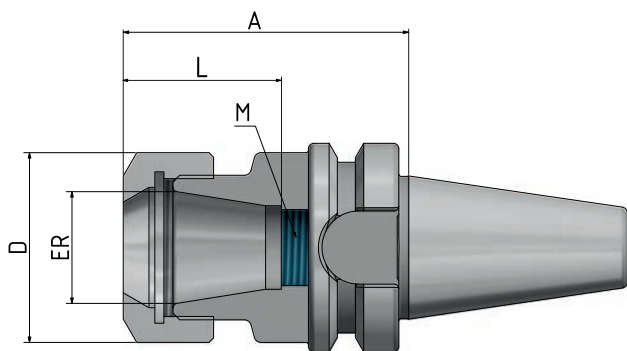

Fig. shows A = 100

Order No.	BT	ER	Clamping range	A	D	L	M	Version
753002-01	30	11	1–7	60	19	60	M8x1	Extra short
753002-02	30	16	1–10	60	28	58	M11x1	Extra short
753002-03	30	20	1–13	60	34	69	M14x1	Extra short
753002-04	30	25	1–16	60	42	75	M18x1,5	Extra short
753002-05	30	32	4–26	60	63	75	M28x1,5	Extra short
753002-22	30	16	1–10	80	28	80	M11x1	Short
753002-23	30	20	1–13	80	34	69	M14x1	Short
753002-24	30	25	1–16	80	42	75	M18x1,5	Short
753002-31	30	11	1–7	100	19	100	M8x1	Long
753002-32	30	16	1–10	100	28	100	M11x1	Long
753002-33	30	20	1–13	100	34	69	M14x1	Long
753002-34	30	25	1–16	100	42	75	M18x1,5	Long



Sealed versions
see pages 186, 187.

Shrink fit holder 4.5°

Application: For clamping tools with cylindrical shank of solid carbide or HSS, tol. h6.

Technical Design: Made of special heat resistant steel. Suitable for inductive shrinking unit. With four additional threads for supplementary fine balancing. Runout of outer taper to $D1 \leq 0,003$ mm.

Includes: Set screw.

Accessories: See page 188.

 **FINE BALANCED**
G 2,5 at 25.000^{min}-1 or max.
residual imbalance ≤ 1 gmm

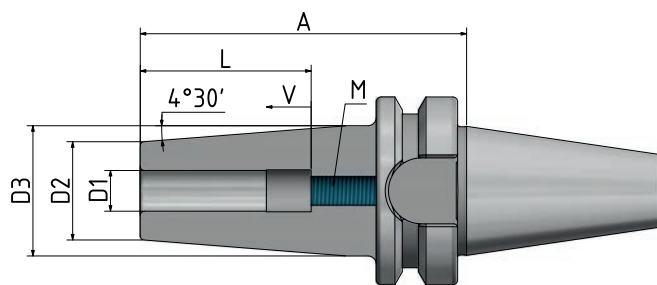

Order No.	BT	D1	A	D2	D3	L	V	M	Version
753021-13	30	3	80	12	17	-	-	-	Short
753021-14	30	4	80	12	17	-	-	-	Short
753021-15	30	5	80	12	17	-	-	-	Short
753021-01	30	6	80	21	27	37	10	M5	Short
753021-02	30	8	80	21	27	37	10	M6	Short
753021-03	30	10	80	24	32	42	10	M8x1	Short
753021-04	30	12	80	24	32	48	10	M10x1	Short
753021-05	30	14	80	27	34	48	10	M10x1	Short
753021-06	30	16	80	27	34	51	10	M12x1	Short
753021-07	30	18	90	33	42	51	10	M12x1	Short
753021-08	30	20	90	33	42	53	10	M16x1	Short

BT 30 ISO 7388-2 Form JD

Shrink fit holder 4,5 Grad „Cool Tool“

Application: Particularly suitable for tools without internal coolant, and for machining at difficult positions with bad chip removal.

Technical Design: Made of special heat resistant steel. Suitable for inductive shrinking unit. With four additional threads for supplementary fine balancing. Runout of outer taper to $D1 \leq 0,003$ mm. With four additional threads for supplementary fine balancing. Two holes in the toolholder lead the coolant directly to the cutting edge.

Includes: Set screw and 2 x M3-screws to plug the coolant holes if needed.

Accessories: See page 188.

FINE BALANCED
G 2,5 at 25.000^{min-1} or max.
residual imbalance ≤ 1 gmm

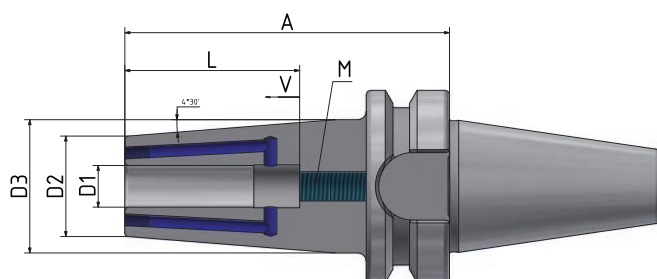

Order No.	BT	D1	A	D2	D3	L	V	M	Version
753021-019	30	6	80	21	27	37	10	M5	Short
753021-029	30	8	80	21	27	37	10	M6	Short
753021-039	30	10	80	24	32	42	10	M8x1	Short
753021-049	30	12	80	24	32	48	10	M10x1	Short
753021-069	30	16	80	34	34	51	10	M12x1	Short
753021-089	30	20	90	42	42	53	10	M16x1	Short



Shell mill holder „Cool Tool“

Application: For adapting shell mills with transverse slot, with coolant mandrel on the cutting edge.

Technical Design: With extended flange.
Runout of outer taper to $D1 \leq 0,006$ mm.

Includes: Clamping screw and drive keys.

Accessories: See page 189.

FINE BALANCED
G 2,5 at 25.000^{min}-1 or max.
residual imbalance ≤ 1 gmm

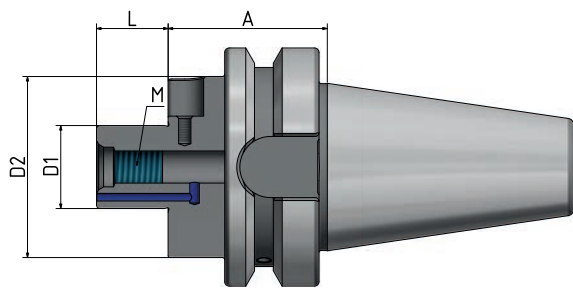

Fig. shows A = 35

Order No.	BT	D1	A	D2	L	M	Version
7530051-01	30	16	35	38	17	M8	Short
7530051-02	30	22	35	48	19	M10	Short
7530051-03	30	27	35	60	21	M12	Short



HPC – Precision ER collet chuck HAWK EYE®

Application: For clamping tools with cylindrical shank in collets ER.

Technical Design: Due to high precision taper tolerances of the ER-Inner taper and the collet taper max. runout of $\leq 5 \mu$ at $2,5 \times D$, subject the usage of our HP 2μ ER collets. The deep fit of the collet inside the chuck combined with a surface treated clamping nut achieves more than double clamping force compared to standard ER collet chuck. HAWK EYE® has an enforced body for max. radial rigidity. The patented special design of HAWK EYE® chuck is only suitable to clamp nominal diameters of the collet used.

Includes: Special clamping nut.

Accessories: See page 183.

FINE BALANCED
G 2,5 at 25.000^{min-1} or max.
residual imbalance ≤ 1 gmm

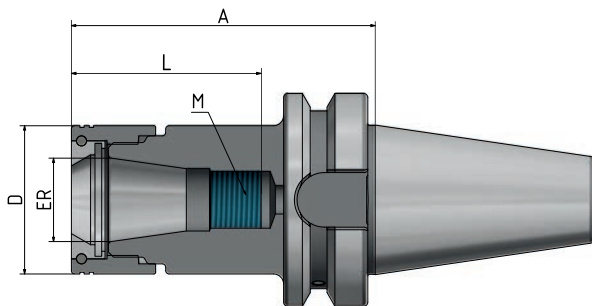

Fig. shows A = 160

Order No.	BT	ER	D	A	Clamping range	L	M	Version
754032-02	40	16	34	70	1–10	52	M11x1	Short
754032-03	40	20	38	70	1–13	57	M18x1	Short
754032-04	40	25	44	70	1–16	69	M18x1,5	Short
754032-05	40	32	52	70	2–20	78	M24x1,5	Short
754032-06	40	40	62	70	4–26	87	M28x1,5	Short
754032-32	40	16	34	100	1–10	100	M11x1	Long
754032-34	40	25	44	100	1–16	69	M18x1,5	Long
754032-35	40	32	52	100	2–20	78	M24x1,5	Long
754032-36	40	40	62	100	4–26	87	M28x1,5	Long
754032-52	40	16	34	130	1–10	130	M11x1	Long
754032-54	40	25	44	130	1–16	69	M18x1,5	Long
754032-55	40	32	52	130	2–20	78	M24x1,5	Long
754032-62	40	16	34	160	1–10	160	M11x1	Extra long
754032-64	40	25	44	160	1–16	69	M18x1,5	Extra long
754032-65	40	32	52	160	2–20	78	M24x1,5	Extra long



Sealed versions
see pages 186, 187.

HPC – Precision ER collet chuck HAWK EYE® „Mini“

Application: For clamping tools with cylindrical shank in collets ER.

Technical Design: Due to high precision taper tolerances of the ER-Inner taper and the collet taper max. runout of $\leq 5 \mu$ at $2,5 \times D$, subject the usage of our HP 2μ ER collets. The deep fit of the collet inside the chuck combined with a surface treated clamping nut achieves more than double clamping force compared to standard ER collet chuck. HAWK EYE® has an enforced body for max. radial rigidity. The patented special design of HAWK EYE® chuck is only suitable to clamp nominal diameters of the collet used.

Includes: Special clamping nut.

Accessories: See page 183.

FINE BALANCED
G 2,5 at 25.000^{min-1} or max.
residual imbalance ≤ 1 gmm

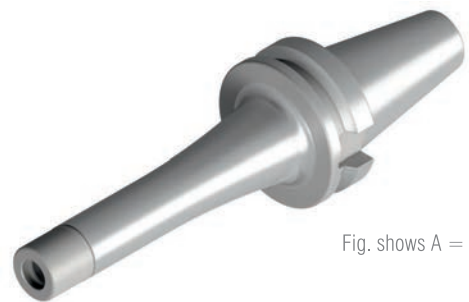
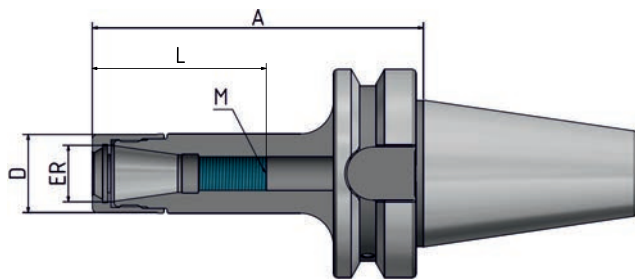
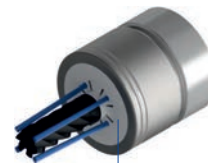

Fig. shows A = 160

Order No.	BT	ER	D	Clamping			M	Version
				range	L	A		
754034-31	40	11	16	1-7	48	100	M8x1	Short
754034-32	40	16	24	1-10	100	100	M11x1	Short
754034-61	40	11	16	1-7	48	160	M8x1	Extra long
754034-62	40	16	24	1-10	160	160	M11x1	Extra long



Sealed versions
see pages 186, 187.

BT 40 ISO 7388-2 Form JD/JF

ER-Collet chuck

Application: For clamping tools with cylindrical shank in collets ER.

Technical Design: Runout of outer taper to inner taper $\leq 0,003$ mm.
Due to adjusted taper tolerances of the ER-Inner taper and the collet taper max. runout of $\leq 8 \mu$ at $2,5 \times D$.

Includes: Clamping nut.

Accessories: See page 183.

FINE BALANCED
G 2,5 at 25.000^{min-1} or max.
residual imbalance ≤ 1 gmm

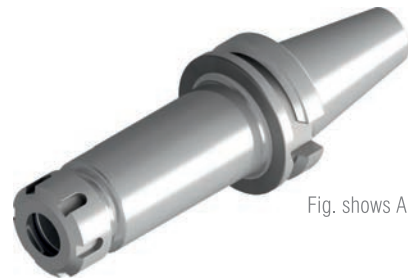
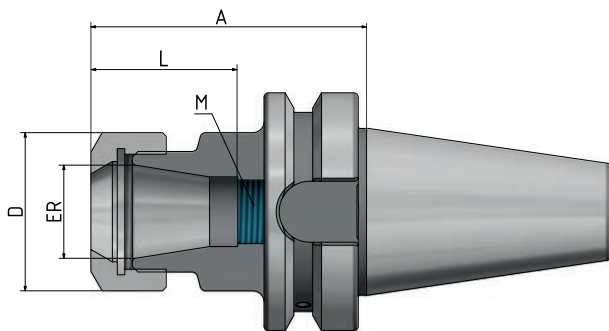

Fig. shows A = 160

Order No.	BT	ER	Clamping		A	D	L	M	Version
			range						
754002-01	40	16	1-10		70	28	70	M11x1	Short
754002-02	40	20	1-13		70	34	70	M14x1	Short
754002-03	40	25	1-16		70	42	75	M18x1,5	Short
754002-04	40	32	2-20		70	50	82	M24x1,5	Short
754002-05	40	40	4-26		70	63	86	M28x1,5	short
754002-31	40	16	1-10		100	28	100	M11x1	Long
754002-32	40	20	1-13		100	34	100	M14x1	Long
754002-33	40	25	1-16		100	42	75	M18x1,5	Long
754002-34	40	32	2-20		100	50	87	M24x1,5	Long
754002-35	40	40	4-26		100	63	96	M25x1,5	Long
754002-61	40	16	1-10		160	28	160	M11x1	Extra long
754002-62	40	20	1-13		160	34	160	M14x1	Extra long
754002-63	40	25	1-16		160	42	75	M18x1,5	Extra long
754002-64	40	32	2-20		160	50	82	M24x1,5	Extra long
754002-65	40	40	4-26		160	63	96	M28x1,5	Extra long



Sealed versions
see pages 186, 187.

ER-Collet chuck „Mini“

Application: For clamping tools with cylindrical shank in collets ER.

Technical Design: Runout of outer taper to inner taper $\leq 0,003$ mm.
Due to adjusted taper tolerances of the ER-Inner taper and the collet taper max. runout of $\leq 8 \mu$ at $2,5 \times D$.

Includes: Clamping nut.

Accessories: See page 183.

FINE BALANCED
G 2,5 at 25.000^{min-1} or max.
residual imbalance ≤ 1 gmm

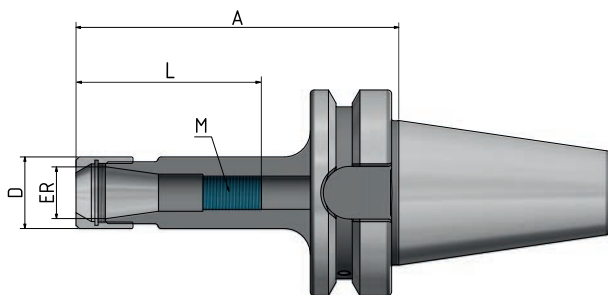

Fig. shows A = 160

Order No.	BT	ER	Clamping range	A	D	L	M	Version
754002-41	40	11	1-7	100	16	49	M8x1	Long
754002-43	40	16	1-10	100	22	100	M11x1	Long
754002-45	40	25	1-16	100	35	75	M18x1,5	Long
754002-42	40	11	1-7	160	16	49	M8x1	Extra long
754002-44	40	16	1-10	160	22	160	M11x1	Extra long
754002-46	40	25	1-16	160	35	75	M18x1,5	Extra long

BT 40 ISO 7388-2 Form JD/JF

Endmill holder Weldon

- Application:** For clamping tools with cylindrical shank according to DIN 1835B/6359HB.
- Technical Design:** Runout of outer taper to $D1 \leq 0,003$ mm.
Tolerance of bore H4 (more accurate as DIN).
- Includes:** Clamping screw, from $\varnothing 25$ with 2 clamping screws.
- Accessories:** See page 188.

FINE BALANCED
G 2,5 at 25.000^{min}-1 or max.
residual imbalance ≤ 1 gmm

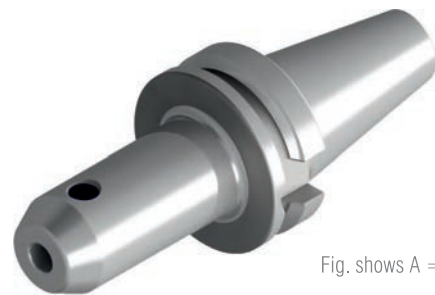
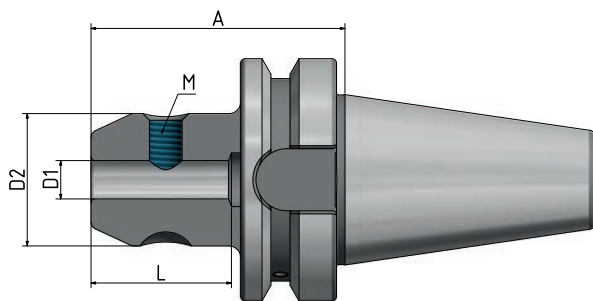

Fig. shows A = 100



Fig. shows $\varnothing 25$ with 2 clamping screws

Order No.	BT	D1	A	D2	L	M	Version
754004-01	40	6	50	25	35	M6	Short
754004-02	40	8	50	28	35	M8	Short
754004-03	40	10	63	35	41	M10	Short
754004-04	40	12	63	42	48	M12	Short
754004-05	40	14	63	44	48	M12	Short
754004-06	40	16	63	48	51	M14	Short
754004-07	40	18	63	48	51	M14	Short
754004-08	40	20	63	52	53	M16	Short
754004-09	40	25	90	65	60	M18x2	Short
754004-10	40	32	100	72	64	M20x2	Short
754004-31	40	6	100	25	35	M6	Long
754004-32	40	8	100	28	35	M8	Long
754004-33	40	10	100	35	41	M10	Long
754004-34	40	12	100	42	48	M12	Long
754004-36	40	16	100	48	51	M14	Long
754004-38	40	20	100	52	53	M16	Long

Shrink fit holder 4,5°

Application: For clamping tools with cylindrical shank of solid carbide or HSS, tol. h6.

Technical Design: Made of special heat resistant steel. Suitable for inductive shrinking unit. With four additional threads for supplementary fine balancing. Runout of outer taper to $D1 \leq 0,003$ mm.

Includes: Set screw.

Accessories: See page 188.

FINE BALANCED
G 2,5 at 25.000^{min}-1 or max.
residual imbalance ≤ 1 gmm

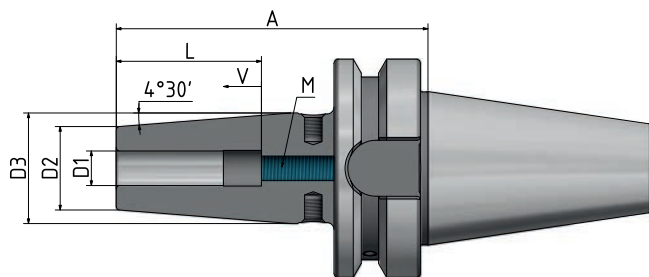

Fig. shows A = 130

Order No.	BT	D1	A	D2	D3	L	V	M	Version
754021-13	40	3	90	12	17	-	-	-	Short
754021-14	40	4	90	12	17	-	-	-	Short
754021-15	40	5	90	12	17	-	-	-	Short
754021-01	40	6	90	21	27	37	10	M5	Short
754021-02	40	8	90	21	27	37	10	M6	Short
754021-03	40	10	90	24	32	42	10	M8x1	Short
754021-04	40	12	90	24	32	48	10	M10x1	Short
754021-05	40	14	90	27	34	48	10	M10x1	Short
754021-06	40	16	90	27	34	51	10	M12x1	Short
754021-07	40	18	90	33	42	51	10	M12x1	Short
754021-08	40	20	90	33	42	53	10	M16x1	Short
754021-09	40	25	100	44	53	59	10	M16x1	Short
754021-31	40	6	120	21	27	37	10	M5	Long
754021-32	40	8	120	21	27	37	10	M6	Long
754021-33	40	10	120	24	32	42	10	M8x1	Long
754021-34	40	12	120	24	32	48	10	M10x1	Long
754021-35	40	14	120	27	34	48	10	M10x1	Long
754021-36	40	16	120	27	34	51	10	M12x1	Long
754021-37	40	18	120	33	42	51	10	M12x1	Long
754021-38	40	20	120	33	42	53	10	M16x1	Long
754021-39	40	25	120	44	53	59	10	M16x1	Long

Shrink fit holder 4,5° (Continuation)

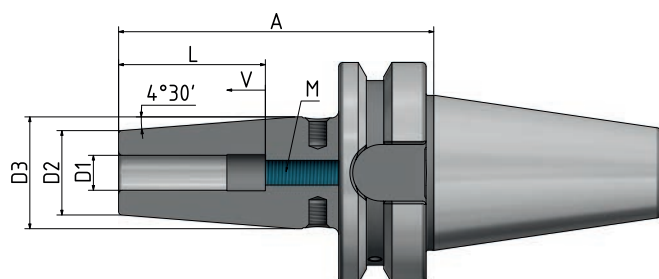

Fig. shows A = 130

Order No.	BT	D1	A	D2	D3	L	V	M	Version
754021-513	40	3	130	12	17	-	-	-	Long
754021-514	40	4	130	12	17	-	-	-	Long
754021-515	40	5	130	12	17	-	-	-	Long
754021-51	40	6	130	21	27	37	10	M5	Long
754021-52	40	8	130	21	27	37	10	M6	Long
754021-53	40	10	130	24	32	42	10	M8x1	Long
754021-54	40	12	130	24	32	48	10	M10x1	Long
754021-55	40	14	130	27	34	48	10	M10x1	Long
754021-56	40	16	130	27	34	51	10	M12x1	Long
754021-57	40	18	130	33	42	51	10	M12x1	Long
754021-58	40	20	130	33	42	53	10	M16x1	Long
754021-59	40	25	130	44	53	59	10	M16x1	Long
754021-61	40	6	160	21	27	37	10	M5	Extra long
754021-62	40	8	160	21	27	37	10	M6	Extra long
754021-63	40	10	160	24	32	42	10	M8x1	Extra long
754021-64	40	12	160	24	32	48	10	M10x1	Extra long
754021-65	40	14	160	27	34	48	10	M10x1	Extra long
754021-66	40	16	160	27	34	51	10	M12x1	Extra long
754021-67	40	18	160	33	42	51	10	M12x1	Extra long
754021-68	40	20	160	33	42	53	10	M16x1	Extra long
754021-69	40	25	160	44	53	59	10	M16x1	Extra long
754021-81	40	6	200	21	27	37	10	M5	Extra long
754021-82	40	8	200	21	27	37	10	M6	Extra long
754021-83	40	10	200	24	32	42	10	M8x1	Extra long
754021-84	40	12	200	24	32	48	10	M10x1	Extra long
754021-85	40	14	200	27	34	48	10	M10x1	Extra long
754021-86	40	16	200	27	34	51	10	M12x1	Extra long
754021-87	40	18	200	33	42	51	10	M12x1	Extra long
754021-88	40	20	200	33	42	53	10	M16x1	Extra long
754021-89	40	25	200	44	53	59	10	M16x1	Extra long

Shrink fit holder 4,5° „Cool Tool“

Application: Particularly suitable for tools without internal coolant, and for machining at difficult positions with bad chip removal.

Technical Design: Made of special heat resistant steel. Suitable for inductive shrinking unit. With four additional threads for supplementary fine balancing. Runout of outer taper to $D1 \leq 0,003$ mm. With four additional threads for supplementary fine balancing. Two holes in the toolholder lead the coolant directly to the cutting edge.

Includes: Set screw and 2 x M3-screws to plug the coolant holes if needed.

Accessories: See page 188.

FINE BALANCED
G 2,5 at 25.000^{min}-1 or max.
residual imbalance ≤ 1 gmm

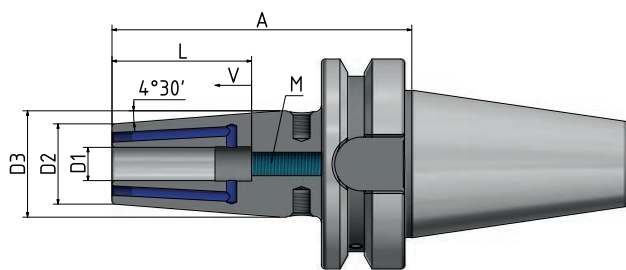

Fig. shows A = 130



Order No.	BT	D1	A	D2	D3	L	V	M	Version
754021-019	40	6	90	21	27	37	10	M5	Short
754021-029	40	8	90	21	27	37	10	M6	Short
754021-039	40	10	90	24	32	42	10	M8x1	Short
754021-049	40	12	90	24	32	48	10	M10x1	Short
754021-059	40	14	90	27	34	48	10	M10x1	Short
754021-069	40	16	90	27	34	51	10	M12x1	Short
754021-079	40	18	90	33	42	51	10	M12x1	Short
754021-089	40	20	90	33	42	53	10	M16x1	Short
754021-099	40	25	100	44	53	59	10	M16x1	Short
754021-519	40	6	130	21	27	37	10	M5	Long
754021-529	40	8	130	21	27	37	10	M6	Long
754021-539	40	10	130	24	32	42	10	M8x1	Long
754021-549	40	12	130	24	32	48	10	M10x1	Long
754021-559	40	14	130	27	34	48	10	M10x1	Long
754021-569	40	16	130	27	34	51	10	M12x1	Long
754021-579	40	18	130	33	42	51	10	M12x1	Long
754021-589	40	20	130	33	42	53	10	M16x1	Long
754021-599	40	25	130	44	53	59	10	M16x1	Long

BT 40 ISO 7388-2 Form JD/JF

Shrink fit holder 3°

Application: For clamping tools with cylindrical shank of solid carbide or HSS, tol. h6.

Technical Design: Made of special heat resistant steel. Suitable for inductive shrinking unit. Runout of outer taper to D1 ≤ 0,003 mm.

FINE BALANCED
G 2,5 at 25.000^{min}-1 or max.
residual imbalance ≤ 1 gmm

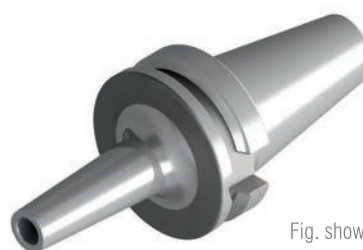
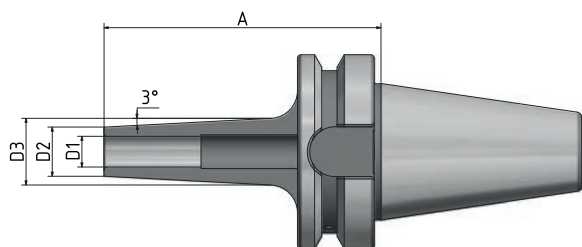

Fig. shows A = 90

Order No.	BT	D1	A	D2	D3	Version
754051-13	40	3	90	9	14	Short
754051-14	40	4	90	10	15	Short
754051-15	40	5	90	11	16	Short
754051-01	40	6	90	12	19	Short
754051-02	40	8	90	14	21	Short
754051-03	40	10	90	16	23	Short
754051-04	40	12	90	18	25	Short
754051-513	40	3	130	9	18	Long
754051-514	40	4	130	10	19	Long
754051-515	40	5	130	11	20	Long
754051-51	40	6	130	12	23	Long
754051-52	40	8	130	14	25	Long
754051-53	40	10	130	16	27	Long
754051-54	40	12	130	18	29	Long

Shell mill holder „Cool Tool“

Application: For adapting shell mills with transverse slot, with coolant mandrel on the cutting edge.

Technical Design: With extended flange.
Runout of outer taper to $D1 \leq 0,006$ mm.

Includes: Clamping screw and drive keys.

Accessories: See page 189.

FINE BALANCED
G 2,5 at 25.000^{min}-1 or max.
residual imbalance ≤ 1 gmm

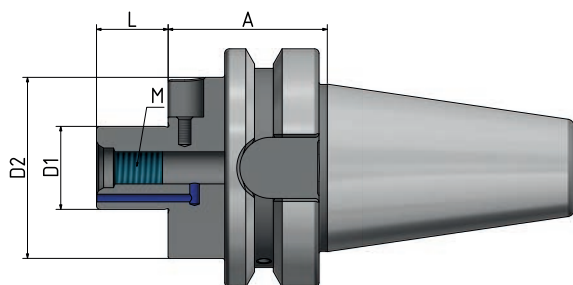

Fig. shows A = 100

Order No.	BT	D1	A	D2	L	M	Version
7540051-01	40	16	35	38	17	M8	Extra short
7540051-02	40	22	35	48	19	M10	Extra short
7540051-03	40	27	35	60	21	M12	Extra short
7540051-04	40	32	50	78	24	M16	Extra short
7540051-05	40	40	50	89	27	M20	Extra short
7540051-31	40	16	100	38	17	M8	Long
7540051-32	40	22	100	48	19	M10	Long
7540051-33	40	27	100	60	21	M12	Long
7540051-34	40	32	100	78	24	M16	Long



BT 40 ISO 7388-2 Form JD/JF

Combi shell mill holder

Application: For adapting shell mills with transverse and longitudinal groove.

Technical Design: Runout of outer taper to $D1 \leq 0,006$ mm.

Includes: Clamping screw, drive key and adjusting spring.

Accessories: See page 190.

 **FINE BALANCED**
G 2,5 at 25.000^{min}-1 or max.
residual imbalance ≤ 1 gmm

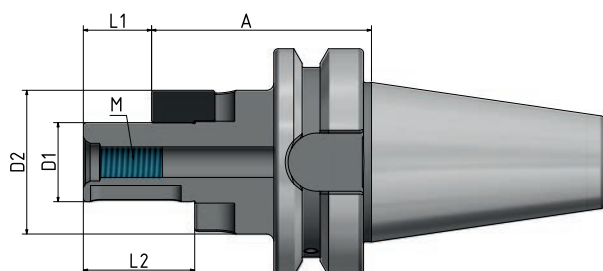

Order No.	BT	D1	A	D2	L1	L2	M	Version
754006-01	40	16	55	32	17	27	M8	Short
754006-02	40	22	55	40	19	31	M10	Short
754006-03	40	27	55	48	21	33	M12	Short
754006-04	40	32	60	58	24	38	M16	Short

Short drill chuck

Application: For clamping tools with cylindrical shank.
Also suitable for tools with internal coolant.

Includes: Wrench

 **FINE BALANCED**
G 6,3 at 18.000^{min}n⁻¹

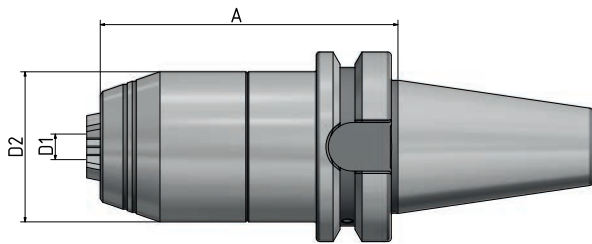

Order No.	BT	Clamping range D1	A	D2
754095-52	40	1-16	88	50

HPC – Precision ER collet chuck HAWK EYE®

Application: For clamping tools with cylindrical shank in collets ER.

Technical Design: Due to high precision taper tolerances of the ER-Inner taper and the collet taper max. runout of $\leq 5 \mu$ at $2,5 \times D$, subject the usage of our HP 2μ ER collets. The deep fit of the collet inside the chuck combined with a surface treated clamping nut achieves more than double clamping force compared to standard ER collet chuck. HAWK EYE® has an enforced body for max. radial rigidity. The patented special design of HAWK EYE® chuck is only suitable to clamp nominal diameters of the collet used.

Includes: Special clamping nut.

Accessories: See page 183.

FINE BALANCED
G 2,5 at 25.000^{min-1} or max.
residual imbalance ≤ 1 gmm

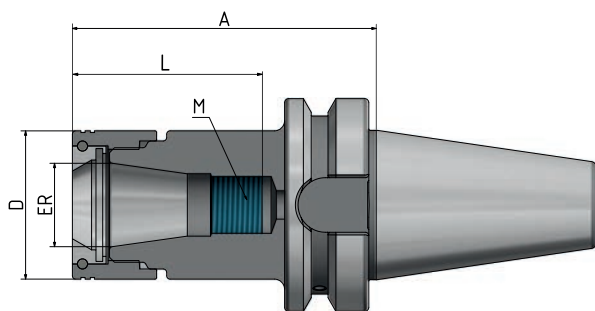

Fig. shows A = 160

Order No.	BT	ER	D	Clamping range			M	Version
				A	L	M		
755032-04	50	25	44	70	1-16	70	M18x1,5	Short
755032-05	50	32	52	70	2-20	78	M24x1,5	Short
755032-06	50	40	62	80	4-26	92	M28x1,5	Short
755032-34	50	25	44	100	1-16	100	M18x1,5	Long
755032-35	50	32	52	100	2-20	92	M24x1,5	Long
755032-36	50	40	62	100	4-26	92	M28x1,5	Long
755032-54	50	25	44	130	1-16	130	M18x1,5	Long
755032-55	50	32	52	130	2-20	78	M24x1,5	Long
755032-56	50	40	62	130	4-26	92	M28x1,5	Long
755032-64	50	25	44	160	1-16	160	M18x1,5	Extra long
755032-65	50	32	52	160	2-20	78	M24x1,5	Extra long
755032-66	50	40	62	160	4-26	92	M28x1,5	Extra long



Sealed versions
see pages 186, 187.

ER-Collet chuck

Application: For clamping tools with cylindrical shank in collets ER.

Technical Design: Runout of outer taper to inner taper $\leq 0,003$ mm.
Due to adjusted taper tolerances of the ER-Inner taper and the collet taper max. runout of $\leq 8 \mu$ at $2,5 \times D$.

Includes: Clamping nut.

Accessories: See page 183.

FINE BALANCED
G 2,5 at 25.000^{min-1} or max.
residual imbalance ≤ 1 gmm

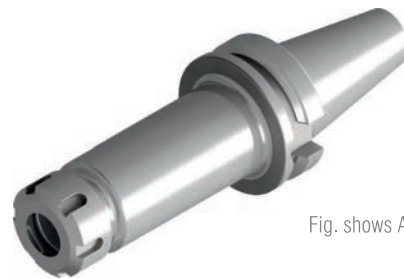
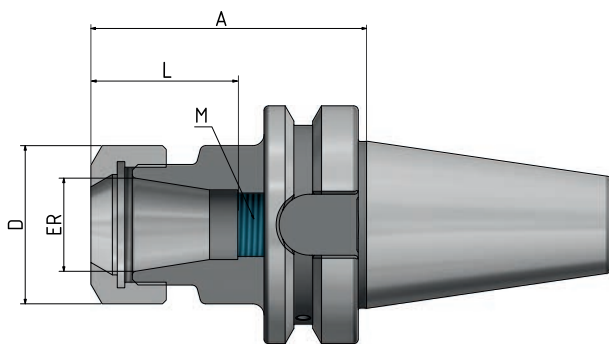

Fig. shows A = 160

Order No.	BT	ER	A	D	Clamping			Version
					range	L	M	
755002-01	50	16	70	28	1-10	58	M11x1	Short
755002-02	50	25	70	42	1-16	69	M18x1,5	Short
755002-03	50	32	70	50	2-20	82	M24x1,5	Short
755002-04	50	40	80	63	4-26	96	M28x1,5	Short
755002-31	50	16	100	28	1-10	100	M11x1	Long
755002-32	50	25	100	42	1-16	100	M18x1,5	Long
755002-33	50	32	100	50	2-20	82	M24x1,5	Long
755002-34	50	40	100	63	4-26	96	M28x1,5	Long
755002-61	50	16	160	28	1-10	160	M11x1	Extra long
755002-62	50	25	160	42	1-16	160	M18x1,5	Extra long
755002-63	50	32	160	50	2-20	82	M24x1,5	Extra long
755002-64	50	40	160	63	4-26	96	M28x1,5	Extra long



Sealed versions
see pages 186, 187.

BT 50 ISO 7388-2 Form JD/JF

Endmill holder Weldon

- Application:** For clamping tools with cylindrical shank according to DIN 1835B/6359HB.
- Technical Design:** Runout of outer taper to $D1 \leq 0,003$ mm.
Tolerance of bore H4 (more accurate as DIN).
- Includes:** Clamping screw, from $\varnothing 25$ with 2 clamping screws.
- Accessories:** See page 188.

FINE BALANCED
G 2,5 at 25.000^{min}-1 or max.
residual imbalance ≤ 1 gmm

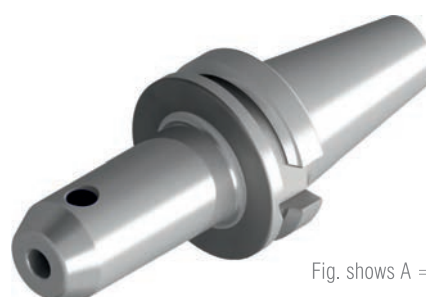
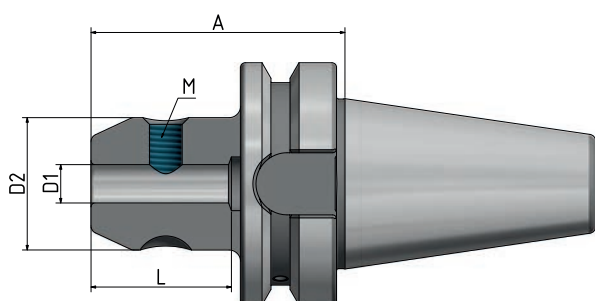

Fig. shows A = 80

Order No.	BT	D1	A	D2	L	M	Version
755004-01	50	6	63	25	35	M6	Short
755004-02	50	8	63	28	35	M8	Short
755004-03	50	10	70	35	41	M10	Short
755004-04	50	12	80	42	48	M12	Short
755004-06	50	16	80	48	51	M14	Short
755004-08	50	20	80	52	53	M16	Short
755004-09	50	25	100	65	60	M18x2	Short
755004-10	50	32	105	72	64	M20x2	Short



Fig. shows $\varnothing 25$ with 2 clamping screws

Shrink fit holder 4,5° with and without „Cool Tool“

Application: For clamping tools with cylindrical shank of solid carbide or HSS, tol. h6.

Technical Design: Made of special heat resistant steel. Suitable for inductive shrinking unit. With four additional threads for supplementary fine balancing. Runout of outer taper to $D1 \leq 0,003$ mm.

Includes: Set screw.

Accessories: See page 188.

FINE BALANCED
G 2,5 at 25.000^{min}-1 or max.
residual imbalance ≤ 1 gmm

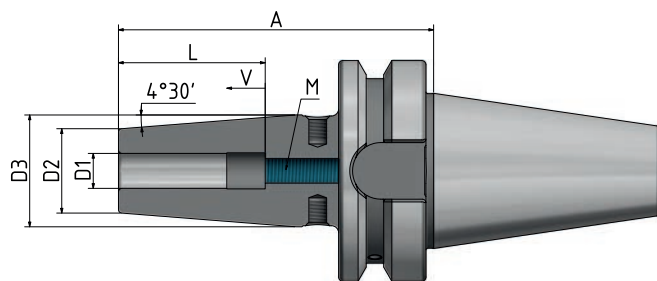

Fig. shows A = 130

Versions without „Cool Tool“:

Order No.	BT	D1	A	D2	D3	L	V	M	Version
755021-01	50	6	100	21	27	37	10	M5	Short
755021-02	50	8	100	21	27	37	10	M6	Short
755021-03	50	10	100	24	32	42	10	M8x1	Short
755021-04	50	12	100	24	32	48	10	M10x1	Short
755021-05	50	14	100	27	34	48	10	M10x1	Short
755021-06	50	16	100	27	34	51	10	M12x1	Short
755021-07	50	18	100	33	42	51	10	M12x1	Short
755021-08	50	20	100	33	42	53	10	M16x1	Short
755021-09	50	25	100	44	53	59	10	M16x1	Short
755021-10	50	32	100	44	53	63	10	M16x1	Short

Version „Cool Tool“:

Order No.	BT	D1	A	D2	D3	L	V	M	Version
755021-019	50	6	100	21	27	37	10	M5	Short
755021-029	50	8	100	21	27	37	10	M6	Short
755021-039	50	10	100	24	32	42	10	M8x1	Short
755021-049	50	12	100	24	32	48	10	M10x1	Short
755021-059	50	14	100	27	34	48	10	M10x1	Short
755021-069	50	16	100	27	34	51	10	M12x1	Short
755021-089	50	18	100	33	42	53	10	M12x1	Short
755021-099	50	20	100	44	53	59	10	M16x1	Short



BT 50 ISO 7388-2
Form JD/JF

Shrink fit holder 4,5° (Continuation)

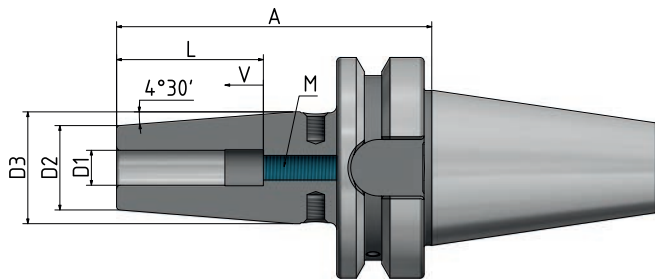

Fig. shows A = 130

Order No.	BT	D1	A	D2	D3	L	V	M	Version
755021-51	50	6	130	21	27	37	10	M5	Long
755021-52	50	8	130	21	27	37	10	M6	Long
755021-53	50	10	130	24	32	42	10	M8x1	Long
755021-54	50	12	130	24	32	48	10	M10x1	Long
755021-55	50	14	130	27	34	48	10	M10x1	Long
755021-56	50	16	130	27	34	51	10	M12x1	Long
755021-57	50	18	130	33	42	51	10	M12x1	Long
755021-58	50	20	130	33	42	53	10	M16x1	Long
755021-59	50	25	130	44	53	59	10	M16x1	Long
755021-60	50	32	130	44	53	63	10	M16x1	Long
755021-61	50	6	160	21	27	37	10	M5	Extra long
755021-62	50	8	160	21	27	37	10	M6	Extra long
755021-63	50	10	160	24	32	42	10	M8x1	Extra long
755021-64	50	12	160	24	32	48	10	M10x1	Extra long
755021-65	50	14	160	27	34	48	10	M10x1	Extra long
755021-66	50	16	160	27	34	51	10	M12x1	Extra long
755021-67	50	18	160	33	42	51	10	M12x1	Extra long
755021-68	50	20	160	33	42	53	10	M16x1	Extra long
755021-69	50	25	160	44	53	59	10	M16x1	Extra long
755021-70	50	32	160	44	53	63	10	M16x1	Extra long
755021-81	50	6	200	21	27	37	10	M5	Extra long
755021-82	50	8	200	21	27	37	10	M6	Extra long
755021-83	50	10	200	24	32	42	10	M8x1	Extra long
755021-84	50	12	200	24	32	48	10	M10x1	Extra long
755021-85	50	14	200	27	34	48	10	M10x1	Extra long
755021-86	50	16	200	27	34	51	10	M12x1	Extra long
755021-87	50	18	200	33	42	51	10	M12x1	Extra long
755021-88	50	20	200	33	42	53	10	M16x1	Extra long
755021-89	50	25	200	44	53	59	10	M16x1	Extra long
755021-90	50	32	200	44	53	63	10	M16x1	Extra long

Shell mill holder „Cool Tool“

Application: For adapting shell mills with transverse slot, with coolant mandrel on the cutting edge.

Technical Design: With extended flange.
Runout of outer taper to $D1 \leq 0,006$ mm.

Includes: Clamping screw and drive keys.

Accessories: See page 189.

FINE BALANCED
G 2,5 at 25.000^{min}-1 or max.
residual imbalance ≤ 1 gmm

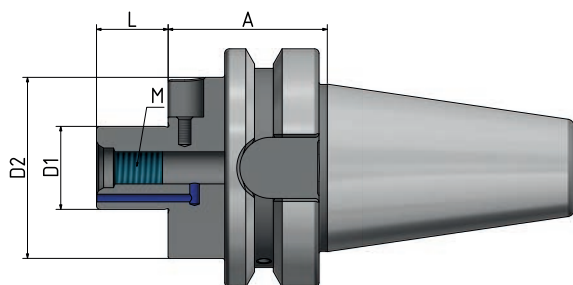

Fig. shows A = 100



Order No.	BT	D1	A	D2	L1	M	Version
7550051-02	50	22	55	48	19	M8	Short
7550051-03	50	27	55	60	21	M10	Short
7550051-04	50	32	55	78	24	M12	Short
7550051-05	50	40	55	89	27	M16	Short
7550051-32	50	22	100	48	19	M8	Long
7550051-33	50	27	100	60	21	M10	Long
7550051-34	50	32	100	78	24	M12	Long

BT 50 ISO 7388-2
Form JD/JF

Combi shell mill holder

- Application:** For adapting shell mills with transverse and longitudinal groove.
- Technical Design:** Runout of outer taper to $D1 \leq 0,006$ mm.
- Includes:** Clamping screw, drive key and adjusting spring.
- Accessories:** See page 190.

FINE BALANCED
G 2,5 at 25.000^{min}-1 or max.
residual imbalance ≤ 1 gmm

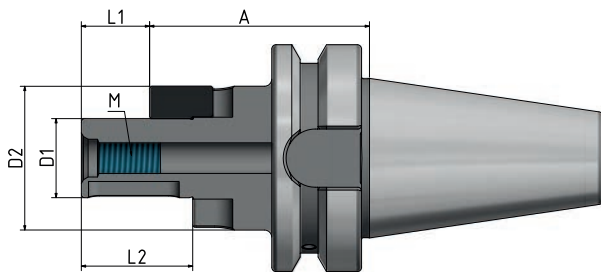

Order No.	BT	D1	A	D2	L1	L2	M	Version
755006-02	50	22	70	40	19	31	M8	Short
755006-03	50	27	70	48	21	33	M10	Short
755006-04	50	32	70	58	24	38	M12	Short
755006-05	50	40	70	70	27	41	M16	Short

Short drill chuck

Application: For clamping tools with cylindrical shank.
Also suitable for tools with internal coolant.

Includes: Wrench

 **FINE BALANCED**
G 6,3 at 18.000^{min}-1

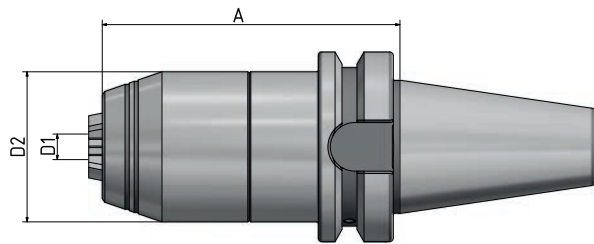

Order No.	BT	Clamping range D1	A	D2
755095-52	50	1-16	99	50

HPC-Präzisions-ER-Collet chuck HAWK EYE® / „Mini“ – BT double contact – BTD

Application: For clamping tools with cylindrical shank in collets ER.

Technical Design: Due to high precision taper tolerances of the ER-Inner taper and the collet taper max. runout of $\leq 5 \mu$ at $2,5 \times D$, subject the usage of our HP 2μ ER collets. The deep fit of the collet inside the chuck combined with a surface treated clamping nut achieves more than double clamping force compared to standard ER collet chuck. HAWK EYE® has an enforced body for max. radial rigidity. The patented special design of HAWK EYE® chuck is only suitable to clamp nominal diameters of the collet used.

Includes: Special clamping nut.

Accessories: See page 183.

FINE BALANCED
G 2,5 at 25.000^{min-1} or max.
residual imbalance ≤ 1 gmm

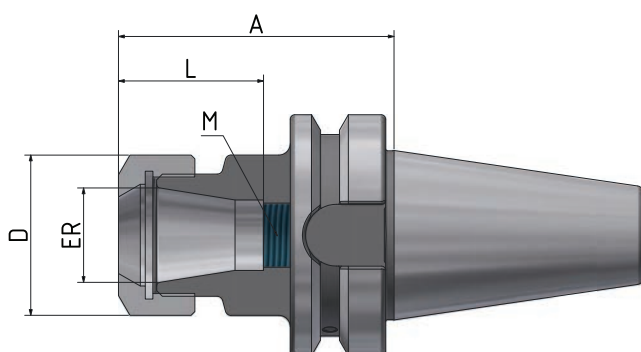

Order No.	BTD	ER	Clamping range				M	Version
			A	D	L	M		
773032-02	30	16	1–10	60	34	52	M11x1	Extra short
773032-03	30	20	1–13	60	38	63	M14x1	Extra short
773032-04	30	25	1–16	60	44	69	M18x1,5	Extra short
773032-05	30	32	2–20	60	52	63	M24x1,5	Extra short
773032-53	30	25	1–16	75	44	69	M18x1,5	Short
773032-54	30	32	2–20	75	52	58	M24x1,5	Short
773032-42	30	16	1–10	90	34	90	M11x1	Short
773032-43	30	20	1–13	90	38	63	M14x1	Short
773032-44	30	25	1–16	90	44	69	M18x1,5	Short
773032-45	30	32	2–20	90	52	78	M24x1,5	Short

ER „Mini“

Order No.	BTD	ER	Clamping range				M	Version
			A	D	L	M		
773034-01	30	11	1–7	100	16	100	M8x1	Long
773034-02	30	16	1–10	100	24	100	M11x1	Long

ER-Collet chuck – BT double contact – BTD

Application: For clamping tools with cylindrical shank in collets ER.

Technical Design: Runout of outer taper to inner taper $\leq 0,003$ mm.
Due to adjusted taper tolerances of the ER-Inner taper and the collet taper max. runout of $\leq 8 \mu$ at $2,5 \times D$.

Includes: Clamping nut.

Accessories: See page 183.

FINE BALANCED
G 2,5 at 25.000^{min-1} or max.
residual imbalance ≤ 1 gmm

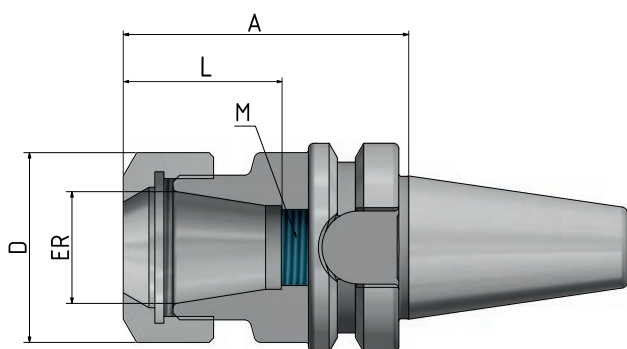

Fig. shows A = 100

Order No.	BTD	ER	Clamping range	A	D	L	M	Version
773002-02	30	16	1–10	60	28	60	M11x1	Extra short
773002-03	30	20	1–13	60	34	69	M14x1	Extra short
773002-04	30	25	1–16	60	42	75	M18x1,5	Extra short
773002-05	30	32	2–20	60	50	75	M24x1,5	Extra short
773002-32	30	16	1–10	100	28	100	M11x1	Long
773002-33	30	20	1–13	100	34	71	M14x1	Long
773002-34	30	25	1–16	100	42	75	M18x1,5	Long
773002-35	30	32	2–20	100	50	82	M24x1,5	Long



Sealed versions
see pages 186, 187.

Shrink fit holder 4,5 Grad – BT double contact – BTD

Application: For clamping tools with cylindrical shank of solid carbide or HSS, tol. h6.

Technical Design: Made of special heat resistant steel. Suitable for inductive shrinking unit. With four additional threads for supplementary fine balancing. Runout of outer taper to $D1 \leq 0,003$ mm.

Includes: Set screw.

Accessories: See page 188.

FINE BALANCED
G 2,5 at 25.000^{min}-1 or max.
residual imbalance ≤ 1 gmm

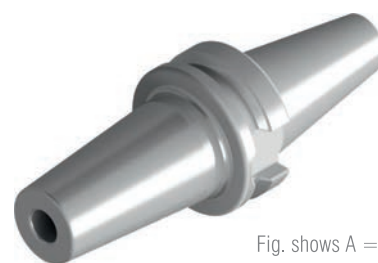
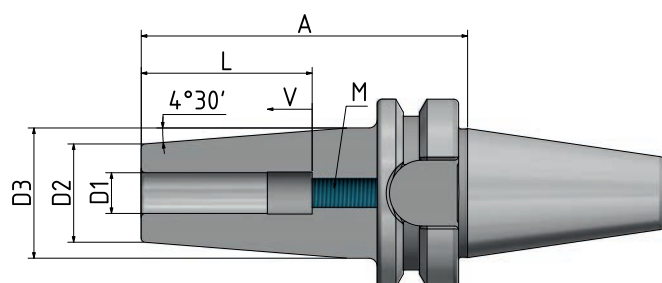

Fig. shows A = 80

Order No.	BTD	D1	A	D2	D3	L	V	M	Version
773021-13	30	3	80	12	17	-	-	-	Short
773021-14	30	4	80	12	17	-	-	-	Short
773021-15	30	5	80	12	17	-	-	-	Short
773021-01	30	6	80	21	27	37	10	M5	Short
773021-02	30	8	80	21	27	37	10	M6	Short
773021-03	30	10	80	24	32	42	10	M8X1	Short
773021-04	30	12	80	24	32	48	10	M10X1	Short
773021-06	30	16	80	27	34	51	10	M12X1	Short
773021-08	30	20	90	33	42	53	10	M16X1	Short

Shell mill holder „Cool Tool“ – BT double contact – BTD

Application: For adapting shell mills with transverse slot, with coolant mandrel on the cutting edge.

Technical Design: With extended flange.
Runout of outer taper to $D1 \leq 0,006$ mm.

Includes: Clamping screw and drive keys.

Accessories: See page 189.

 **FINE BALANCED**
G 2,5 at 25.000^{min}-1 or max.
residual imbalance ≤ 1 gmm

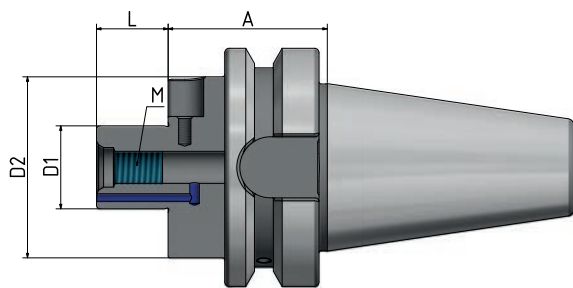

Order No.	BTD	D1	A	D2	L	M	Version
7730051-01	30	16	35	38	17	M8	Short
7730051-02	30	22	35	48	19	M10	Short
7730051-03	30	27	35	60	21	M12	Short



ER-Collet chuck – BT double contact – BTD

Application: For clamping tools with cylindrical shank in collets ER.

Technical Design: Runout of outer taper to inner taper $\leq 0,003$ mm.
Due to adjusted taper tolerances of the ER-Inner taper and the collet taper max. runout of $\leq 8 \mu$ at $2,5 \times D$.

Includes: Clamping nut.

Accessories: See page 183.

FINE BALANCED
G 2,5 at 25.000^{min-1} or max.
residual imbalance ≤ 1 gmm

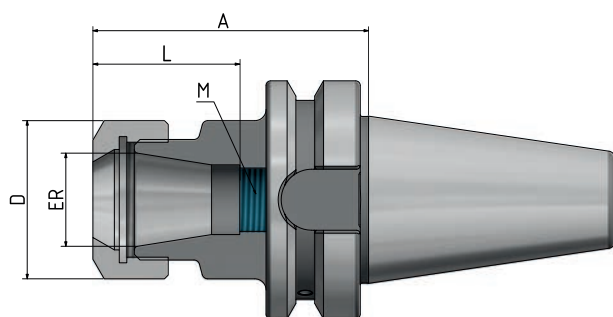

Fig. shows A = 100

Order No.	BTD	ER	Clamping range				M	Version
			A	D	L	M		
774002-01	40	16	1–10	70	28	70	M11x1	Short
774002-02	40	20	1–13	70	42	70	M18x1,5	Short
774002-03	40	25	1–16	70	50	75	M24x1,5	Short
774002-04	40	32	2–20	70	63	82	M28x1,5	Short
774002-31	40	16	1–10	100	28	100	M11x1	Long
774002-32	40	20	1–13	100	42	100	M18x1,5	Long
774002-33	40	25	1–16	100	50	75	M24x1,5	Long
774002-34	40	32	2–20	100	63	82	M28x1,5	Long



Sealed versions
see pages 186, 187.

Endmill holder Weldon – BT double contact – BTD

- Application:** For clamping tools with cylindrical shank according to DIN 1835B/6359HB.
- Technical Design:** Runout of outer taper to $D1 \leq 0,003$ mm.
Tolerance of bore H4 (more accurate as DIN).
- Includes:** Clamping screw, from $\varnothing 25$ with 2 clamping screws.
- Accessories:** See page 188.

FINE BALANCED
G 2,5 at 25.000^{min}-1 or max.
residual imbalance ≤ 1 gmm

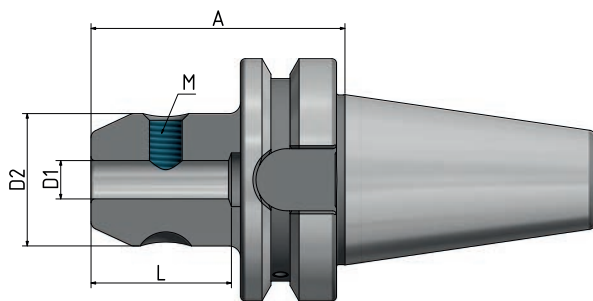

Order No.	BTD	D1	A	D2	L	M	Version
774004-01	40	6	50	25	35	M6	Short
774004-02	40	8	50	28	35	M8	Short
774004-03	40	10	63	35	41	M10	Short
774004-04	40	12	63	42	48	M12	Short
774004-06	40	16	63	48	51	M14	Short
774004-08	40	20	63	52	53	M16	Short
774004-09	40	25	90	65	60	M18x2	Short
774004-10	40	32	100	72	64	M20x2	Short



Fig. shows $\varnothing 25$ with 2 clamping screws

BTD 40
Form JD

Shrink fit holder 4,5 Grad – BT double contact – BTD

Application: For clamping tools with cylindrical shank of solid carbide or HSS, tol. h6.

Technical Design: Made of special heat resistant steel. Suitable for inductive shrinking unit. With four additional threads for supplementary fine balancing. Runout of outer taper to $D1 \leq 0,003$ mm.

Includes: Set screw.

Accessories: See page 188.

FINE BALANCED
G 2,5 at 25.000^{min}-1 or max.
residual imbalance ≤ 1 gmm

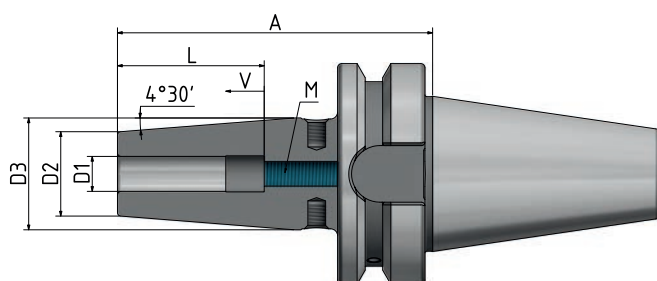

Order No.	BTD	D1	A	D2	D3	L	V	M	Version
774021-13	40	3	90	12	17	-	-	-	Short
774021-14	40	4	90	12	17	-	-	-	Short
774021-15	40	5	90	12	17	-	-	-	Short
774021-01	40	6	90	21	27	37	10	M5	Short
774021-02	40	8	90	21	27	37	10	M6	Short
774021-03	40	10	90	24	32	42	10	M8x1	Short
774021-04	40	12	90	24	32	48	10	M10x1	Short
774021-06	40	16	90	27	34	51	10	M12x1	Short
774021-08	40	20	90	33	42	53	10	M16x1	Short
774021-09	40	25	100	44	53	59	10	M16x1	Short

Shell mill holder „Cool Tool“ – BT double contact – BTD

Application: For adapting shell mills with transverse slot, with coolant mandrel on the cutting edge.

Technical Design: With extended flange.
Runout of outer taper to $D1 \leq 0,006$ mm.

Includes: Clamping screw and drive keys.

Accessories: See page 189.

 **FINE BALANCED**
G 2,5 at 25.000^{min}-1 or max.
residual imbalance ≤ 1 gmm

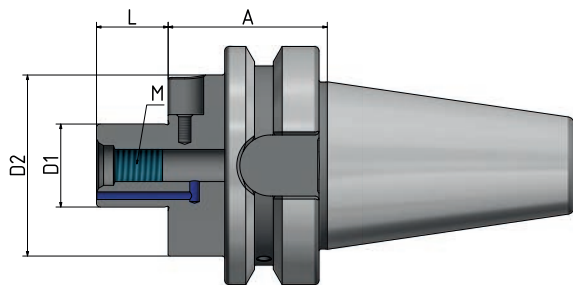

Order No.	BTD	D1	A	D2	L	M	Version
7740051-02	40	22	35	48	19	M10	Short
7740051-03	40	27	35	60	21	M12	Short
7740051-04	40	32	50	78	24	M16	Short



TOOL HOLDERS

WITH POLYGONAL SHANK CORUM C4, C5, C6, C8
ISO 26623

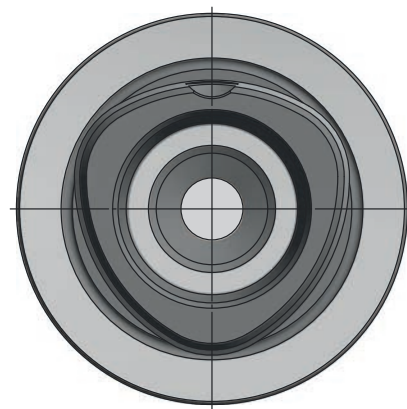
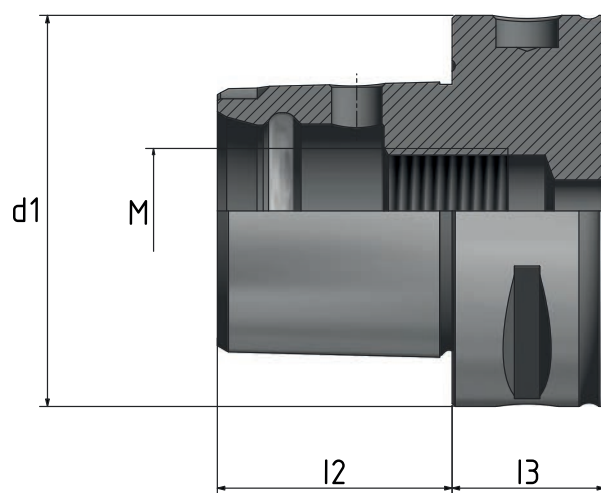

C	d1	l2	l3	M
4	40	24	20	M14x1,5
5	50	30	20	M16x1,5
6	63	38	22	M20x2
8	80	48	30	M20x2

CORUM – Tool holders with polygonal shank

$$x' = Dm/2 x \cos y - 2 x e \cos(2y) + e x \cos(4y)$$

We are proud to present our new generation of tool holders: CORUM. The shape of the polygonal section, similar to a heart, was the inspiration for the name («Cor», lat. for »heart«).

With this expansion in our product range, we offer an attractive alternative in the polygon toolholders. According to our slogan "the μ -maker", we guarantee also with these toolholders highest precision and quality. In addition to the perfect polygonal shape our toolholders convince by many thoughtful details:

- Fine balanced design G2,5 25.000/min.
- Bore for Balluff-Chip as standard
- Hard reworked functional surfaces on the inside geometry, thereby the clamping shoulder concentricity is more accurate than ISO standard (2)
- Many extended versions as standard.

The size designation of our toolholders CORUM with nominal diameter 63 mm is:

→ C6 ←

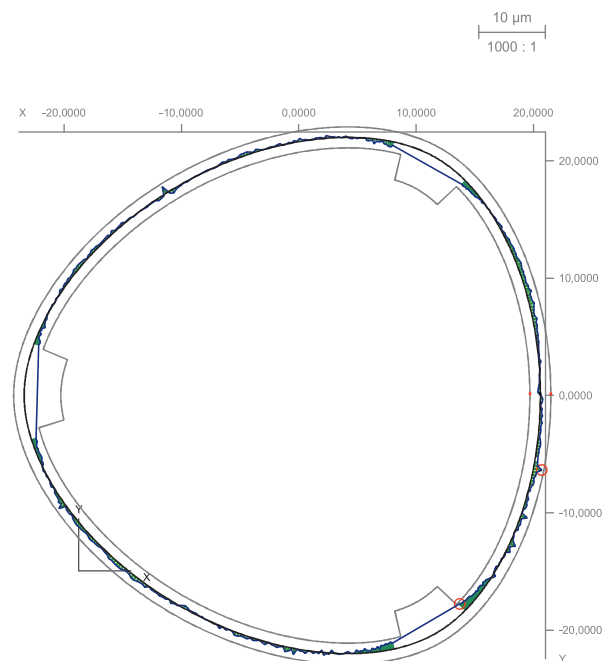
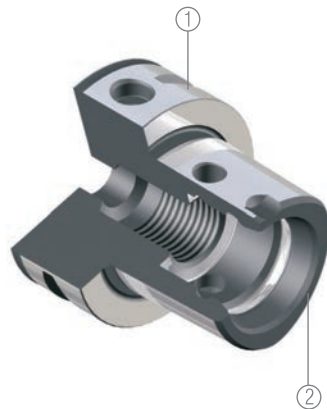

The certified polygon shape of our CORUM tool holder by an independent testing company. Please note the almost perfect overlap of the reference and actual geometry.



CORUM C6

HPC – Precision ER collet chuck HAWK EYE®

Application: For clamping tools with cylindrical shank in collets ER.

Technical Design: Due to high precision taper tolerances of the ER-Inner taper and the collet taper max. runout of $\leq 5 \mu$ at $2,5 \times D$, subject the usage of our HP 2μ ER collets. The deep fit of the collet inside the chuck combined with a surface treated clamping nut achieves more than double clamping force compared to standard ER collet chuck. HAWK EYE® has an enforced body for max. radial rigidity. The patented special design of HAWK EYE® chuck is only suitable to clamp nominal diameters of the collet used.

Includes: Special clamping nut.

Accessories: See page 183.

 **FINE BALANCED**
G 2,5 at 25.000^{min-1} or max.
residual imbalance ≤ 1 gmm

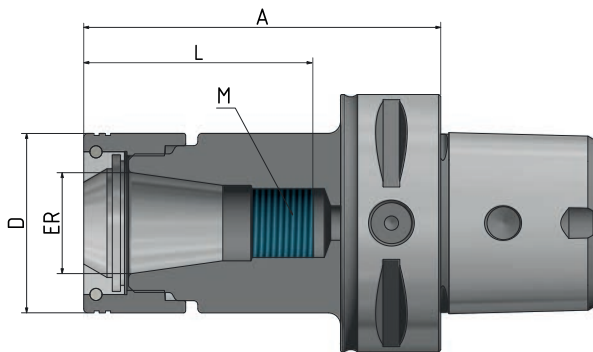

Order No.	C	ER	D	A	Clamping			Version
					range	L	M	
306332-31	6	16	34	100	1–10	100	M11x1	Long
306332-32	6	25	44	100	1–16	69	M18x1,5	Long
306332-33	6	32	52	100	2–20	78	M24x1,5	Long
306332-34	6	40	62	100	4–26	85	M28x1,5	Long

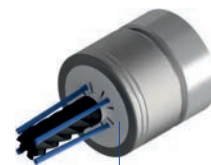

Sealed versions
see pages 186, 187.

ER-Collet chuck

Application: For clamping tools with cylindrical shank in collets ER.

Technical Design: Runout of outer taper to inner taper $\leq 0,003$ mm.
Due to adjusted taper tolerances of the ER-Inner taper and the collet taper max. runout of $\leq 8 \mu$ at $2,5 \times D$.

Includes: Clamping nut.

Accessories: See page 183.

FINE BALANCED
G 2,5 at 25.000^{min-1} or max.
residual imbalance ≤ 1 gmm

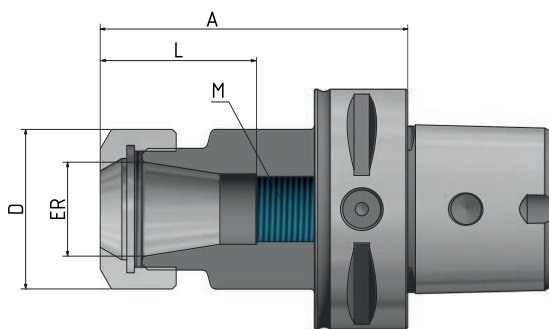

Fig. shows A = 70

Order No.	C	ER	A	D	Clamping range	L	M	Version
304002-01	4	16	70	28	1–10	35	-	Short
304002-02	4	25	55	42	1–16	42	-	Short
304002-03	4	32	55	50	2–20	49	-	Short

Order No.	C	ER	A	D	Clamping range	L	M	Version
305002-01	5	16	55	28	1–10	34	-	Short
305002-02	5	25	55	42	1–16	42	-	Short
305002-03	5	32	60	50	2–20	49	-	Short
305002-31	5	16	100	28	1–10	100	M11x1	Long
305002-32	5	25	100	42	1–16	75	M18x1,5	Long
305002-33	5	32	100	50	2–20	82	M24x1,5	Long



Sealed versions
see pages 186, 187.

CORUM C6, C8

ER-Collet chuck

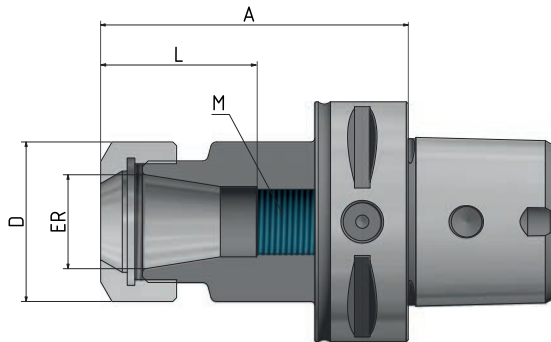

Fig. shows A = 160

Order No.	C	ER	A	D	Clamping range	L	M	Version
306302-01	6	16	60	28	1–10	34	-	Short
306302-02	6	25	60	42	1–16	42	-	Short
306302-03	6	32	60	50	2–20	49	-	Short
306302-04	6	40	65	63	4–26	54	-	Short
306302-31	6	16	100	28	1–10	100	M11x1	Long
306302-32	6	25	100	42	1–16	75	M18x1,5	Long
306302-33	6	32	100	50	2–20	82	M24x1,5	Long
306302-34	6	40	100	63	4–26	81	M28x1,5	Long
306302-52	6	25	130	42	1–16	75	M18x1,5	Long
306302-53	6	32	130	50	2–20	82	M24x1,5	Long
306302-61	6	16	160	28	1–10	160	M11x1	Extra long
306302-62	6	25	160	42	1–16	75	M18x1,5	Extra long
306302-63	6	32	160	50	2–20	82	M24x1,5	Extra long

Order No.	C	ER	A	D	Clamping range	L	M	Version
308002-01	8	16	65	28	1–10	34	-	Short
308002-02	8	25	70	42	1–16	43	-	Short
308002-03	8	32	70	50	2–20	49	-	Short
308002-04	8	40	70	63	4–26	55	-	Short

ER-Collet chuck „Mini“

Application: For clamping tools with cylindrical shank in collets ER.

Technical Design: Runout of outer taper to inner taper $\leq 0,003$ mm.
Due to adjusted taper tolerances of the ER-Inner taper and the collet taper max. runout of $\leq 8 \mu$ at $2,5 \times D$.

Includes: Clamping nut.

Accessories: See page 183.

FINE BALANCED
G 2,5 at 25.000^{min-1} or max.
residual imbalance ≤ 1 gmm

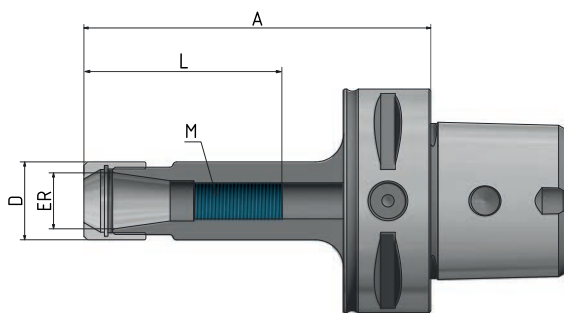

Fig. shows A = 160

Order No.	C	ER	A	D	Clamping range	L	M	Version
306302-21	6	11	100	16	1-7	49	M8x1	Long
306302-22	6	16	100	22	1-10	100	M11x1	Long
306302-23	6	11	160	16	1-7	49	M8x1	Extra long
306302-24	6	16	160	22	1-10	160	M11x1	Extra long

CORUM C4, C5, C6, C8

Endmill holder Weldon

- Application:** For clamping tools with cylindrical shank according to DIN 1835B/6359HB.
- Technical Design:** Runout of outer taper to $D1 \leq 0,003$ mm. Tolerance of bore H4 (more accurate as DIN).
- Includes:** Clamping screw, from $\varnothing 25$ with 2 clamping screws.
- Accessories:** See page 188.

FINE BALANCED
G 2,5 at 25.000^{min}-1 or max.
residual imbalance ≤ 1 gmm

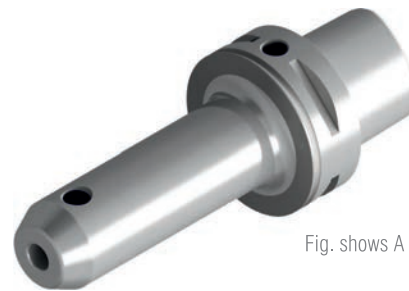
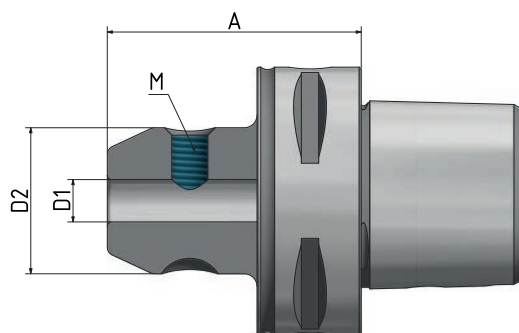

Fig. shows A = 130

Order No.	C	D1	A	D2	M	Version
304004-01	4	6	50	25	M6	Short
304004-02	4	8	50	28	M8	Short
304004-03	4	10	50	35	M10	Short
304004-04	4	12	55	42	M12	Short
304004-05	4	14	55	44	M12	Short
304004-06	4	16	55	48	M14	Short

Order No.	C	D1	A	D2	M	Version
305004-01	5	6	50	25	M6	Short
305004-02	5	8	50	28	M8	Short
305004-03	5	10	55	35	M10	Short
305004-04	5	12	60	42	M12	Short
305004-05	5	14	60	44	M12	Short
305004-06	5	16	60	48	M14	Short
305004-07	5	18	60	50	M14	Short
305004-08	5	20	60	52	M16	Short
305004-09	5	25	80	65	M18x2	Short

Order No.	C	D1	A	D2	M	Version
306304-01	6	6	55	25	M6	Short
306304-02	6	8	55	28	M8	Short
306304-03	6	10	60	35	M10	Short
306304-04	6	12	60	42	M12	Short
306304-05	6	14	60	44	M12	Short
306304-06	6	16	65	48	M14	Short

Order No.	C	D1	A	D2	M	Version
306304-07	6	18	65	50	M14	Short
306304-08	6	20	65	52	M16	Short
306304-09	6	25	80	65	M18x2	Short
306304-10	6	32	90	72	M20x2	Short
306304-31	6	6	100	25	M6	Long
306304-32	6	8	100	28	M8	Long
306304-33	6	10	100	35	M10	Long
306304-34	6	12	100	42	M12	Long
306304-35	6	14	100	44	M12	Long
306304-36	6	16	100	48	M14	Long
306304-37	6	18	100	50	M14	Long
306304-38	6	20	100	52	M16	Long
306304-51	6	6	130	25	M6	Long
306304-52	6	8	130	28	M8	Long
306304-53	6	10	130	35	M10	Long
306304-54	6	12	130	42	M12	Long
306304-56	6	16	130	48	M14	Long
306304-58	6	20	130	52	M16	Long

Order No.	C	D1	A	D2	M	Version
308004-01	8	6	70	25	M6	Short
308004-02	8	8	70	28	M8	Short
308004-03	8	10	70	35	M10	Short
308004-04	8	12	70	42	M12	Short
308004-05	8	14	70	44	M12	Short
308004-06	8	16	70	48	M14	Short
308004-07	8	18	70	50	M14	Short
308004-08	8	20	70	52	M16	Short
308004-09	8	25	80	65	M18x2	Short
308004-10	8	32	80	72	M20x2	Short

Endmill holder Weldon „Cool Tool“

- Application:** Particularly suitable for tools without internal coolant, and for machining at difficult positions with bad chip removal.
- Technical Design:** Two holes in the toolholder lead the coolant directly to the cutting edge. Runout of outer taper to $D1 \leq 0,003$ mm. Tolerance of bore H4 (more accurate as DIN).
- Includes:** Clamping screw (from $\varnothing 25$ with 2 clamping screws) and 2 x M3-screws to plug the coolant holes if needed.
- Accessories:** See page 188.

FINE BALANCED
G 2,5 at 25.000^{min}-1 or max.
residual imbalance ≤ 1 gmm

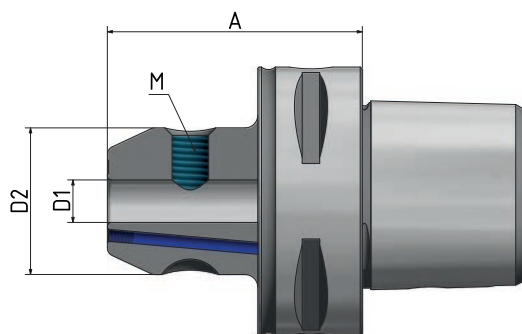

Fig. shows A = 50

Order No.	C	D1	A	D2	M	Version
3040041-01	4	6	50	25	M6	Short
3040041-02	4	8	50	28	M8	Short
3040041-03	4	10	50	35	M10	Short
3040041-04	4	12	55	42	M12	Short
3040041-05	4	14	55	44	M12	Short
3040041-06	4	16	55	48	M14	Short



Fig. shows $\varnothing 25$ with 2 clamping screws

Order No.	C	D1	A	D2	M	Version
3050041-01	5	6	50	25	M6	Short
3050041-02	5	8	50	28	M8	Short
3050041-03	5	10	55	35	M10	Short
3050041-04	5	12	60	42	M12	Short
3050041-05	5	14	60	44	M12	Short
3050041-06	5	16	60	48	M14	Short
3050041-07	5	18	60	50	M14	Short
3050041-08	5	20	60	52	M16	Short
3050041-09	5	25	80	65	M18x2	Short



CORUM C6

Endmill holder Weldon „Cool Tool“

- Application:** Particularly suitable for tools without internal coolant, and for machining at difficult positions with bad chip removal.
- Technical Design:** Two holes in the toolholder lead the coolant directly to the cutting edge.
Runout of outer taper to $D1 \leq 0,003$ mm.
Tolerance of bore H4 (more accurate as DIN).
- Includes:** Clamping screw (from $\varnothing 25$ with 2 clamping screws) and 2 x M3-screws to plug the coolant holes if needed.
- Accessories:** See page 188.

FINE BALANCED
G 2,5 at 25.000^{min}-1 or max.
residual imbalance ≤ 1 gmm

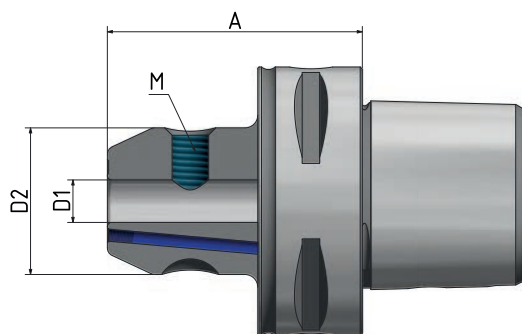

Fig. shows A = 50

Order No.	C	D1	A	D2	M	Version
3063041-01	6	6	55	25	M6	Short
3063041-02	6	8	55	28	M8	Short
3063041-03	6	10	60	35	M10	Short
3063041-04	6	12	60	42	M12	Short
3063041-05	6	14	60	44	M12	Short
3063041-06	6	16	65	48	M14	Short
3063041-07	6	18	65	50	M14	Short
3063041-08	6	20	65	52	M16	Short
3063041-09	6	25	80	65	M18x2	Short
3063041-10	6	32	90	72	M20x2	Short
3063041-31	6	6	100	25	M6	Long
3063041-32	6	8	100	28	M8	Long
3063041-33	6	10	100	35	M10	Long
3063041-34	6	12	100	42	M12	Long
3063041-36	6	16	100	48	M14	Long
3063041-38	6	20	100	52	M16	Long



Fig. shows $\varnothing 25$ with 2 clamping screws



Endmill holder Whistle-Notch

Application: For clamping tools with cylindrical shank according to DIN 1835E/6359HE.

Technical Design: Runout of outer taper to $D1 \leq 0,003$ mm.
Tolerance of bore H4 (more accurate as DIN).

Includes: Clamping screw (from $\varnothing 25$ with 2 clamping screws) and set screw.

Accessories: See page 188.

 **FINE BALANCED**
G 6,3 at $8.000^{\text{min-1}}$

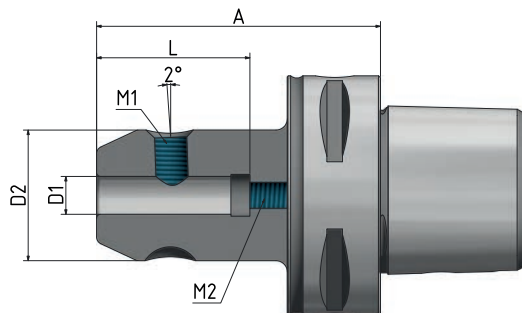

Fig. shows $\varnothing 25$ with 2 clamping screws

Order No.	C	D1	A	D2	L	M1	M2	Version
306309-01	6	6	75	25	36,5	M6	M5	Short
306309-02	6	8	75	28	36,5	M8	M6	Short
306309-03	6	10	75	35	40,5	M10	M8	Short
306309-04	6	12	80	42	45,5	M12	M10	Short
306309-05	6	14	80	44	45,5	M12	M10	Short
306309-06	6	16	80	49	48,5	M14	M12	Short
306309-07	6	18	80	50	48,5	M14	M12	Short
306309-08	6	20	85	52	50,5	M16	M16	Short
306309-09	6	25	90	65	56,5	M18x2	M20	Short
306309-10	6	32	95	72	60,5	M20x2	M20	Short

CORUM C4, C5

Shrink fit holder 4,5°

Application: For clamping tools with cylindrical shank of solid carbide or HSS, tol. h6.

Technical Design: Made of special heat resistant steel. Suitable for inductive shrinking unit. With four additional threads for supplementary fine balancing. Runout of outer taper to $D1 \leq 0,003$ mm.

Includes: Set screw.

Accessories: See page 188.

FINE BALANCED
G 2,5 at 25.000^{min}-1 or max.
residual imbalance ≤ 1 gmm

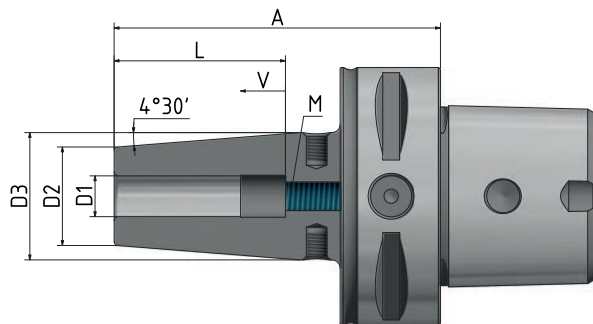

Fig. shows A = 120

Order No.	C	D1	A	D2	D3	L	V	M1	Version
304021-01	4	6	75	21	27	36	10	M5	Short
304021-02	4	8	75	21	27	36	10	M6	Short
304021-03	4	10	75	24	32	42	10	M8x1	Short
304021-04	4	12	75	24	32	47	10	M10x1	Short
304021-05	4	14	80	27	34	47	10	M10x1	Short
304021-06	4	16	80	27	34	50	10	M12x1	Short
304021-07	4	18	80	33	42	50	10	M12x1	Short
304021-08	4	20	85	33	42	52	10	M16x1	Short

Order No.	C	D1	A	D2	D3	L	V	M1	Version
305021-01	5	6	75	21	27	36	10	M5	Short
305021-02	5	8	75	21	27	36	10	M6	Short
305021-03	5	10	75	24	32	42	10	M8x1	Short
305021-04	5	12	75	24	32	47	10	M10x1	Short
305021-05	5	14	80	27	34	47	10	M10x1	Short
305021-06	5	16	80	27	34	50	10	M12x1	Short
305021-07	5	18	80	33	42	50	10	M12x1	Short
305021-08	5	20	85	33	42	52	10	M16x1	Short
305021-09	5	25	90	44	52	58	10	M16x1	Short

Shrink fit holder 4,5° „Cool Tool“

Application: Particularly suitable for tools without internal coolant, and for machining at difficult positions with bad chip removal.

Technical Design: Made of special heat resistant steel. Suitable for inductive shrinking unit. With four additional threads for supplementary fine balancing. Runout of outer taper to $D1 \leq 0,003$ mm. With four additional threads for supplementary fine balancing. Two holes in the toolholder lead the coolant directly to the cutting edge.

Includes: Set screw and 2 x M3-screws to plug the coolant holes if needed.

Accessories: See page 188.

FINE BALANCED
G 2,5 at 25.000^{min}-1 or max.
residual imbalance ≤ 1 gmm

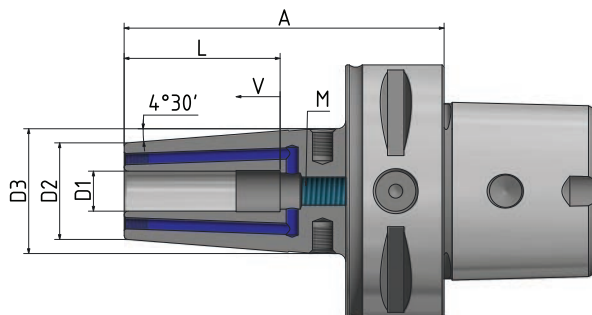

Fig. shows A = 80

Order No.	C	D1	A	D2	D3	L	V	M1	Version
304021-019	4	6	75	21	27	36	10	M5	Short
304021-029	4	8	75	21	27	36	10	M6	Short
304021-039	4	10	75	24	32	42	10	M8x1	Short
304021-049	4	12	75	24	32	47	10	M10x1	Short
304021-059	4	14	80	27	34	47	10	M10x1	Short
304021-069	4	16	80	27	34	50	10	M12x1	Short
304021-079	4	18	80	33	42	50	10	M12x1	Short
304021-089	4	20	85	33	42	52	10	M16x1	Short

Order No.	C	D1	A	D2	D3	L	V	M1	Version
305021-019	5	6	75	21	27	36	10	M5	Short
305021-029	5	8	75	21	27	36	10	M6	Short
305021-039	5	10	75	24	32	42	10	M8x1	Short
305021-049	5	12	75	24	32	47	10	M10x1	Short
305021-059	5	14	80	27	34	47	10	M10x1	Short
305021-069	5	16	80	27	34	50	10	M12x1	Short
305021-079	5	18	80	33	42	50	10	M12x1	Short
305021-089	5	20	85	33	42	52	10	M16x1	Short
305021-099	5	25	90	44	52	58	10	M16x1	Short



CORUM C6

Shrink fit holder 4,5°

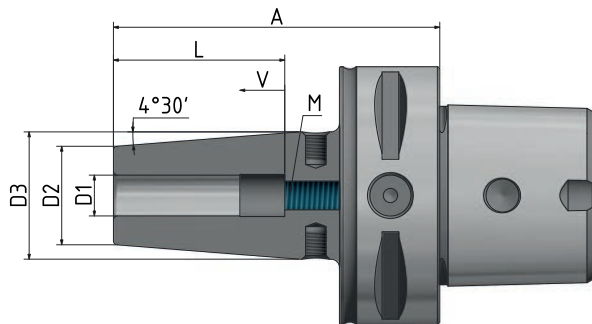

Fig. shows A = 120

Order No.	C	D1	A	D2	D3	L	V	M1	Version
306321-13	6	3	80	12	17	-	-	-	Short
306321-14	6	4	80	12	17	-	-	-	Short
306321-15	6	5	80	12	17	-	-	-	Short
306321-01	6	6	80	21	27	36	10	M5	Short
306321-02	6	8	80	21	27	36	10	M6	Short
306321-03	6	10	80	24	32	42	10	M8x1	Short
306321-04	6	12	80	24	32	47	10	M10x1	Short
306321-05	6	14	85	27	34	47	10	M10x1	Short
306321-06	6	16	85	27	34	50	10	M12x1	Short
306321-07	6	18	85	33	42	50	10	M12x1	Short
306321-08	6	20	85	33	42	52	10	M16x1	Short
306321-09	6	25	90	44	52	58	10	M16x1	Short
306321-10	6	32	95	44	53	62	10	M16x1	Short
306321-31	6	6	120	21	27	36	10	M5	Long
306321-32	6	8	120	21	27	36	10	M6	Long
306321-33	6	10	120	24	32	42	10	M8x1	Long
306321-34	6	12	120	24	32	47	10	M10x1	Long
306321-35	6	14	120	27	34	47	10	M10x1	Long
306321-36	6	16	120	27	34	50	10	M12x1	Long
306321-37	6	18	120	33	42	50	10	M12x1	Long
306321-38	6	20	120	33	42	52	10	M16x1	Long
306321-39	6	25	120	44	52	58	10	M16x1	Long
306321-40	6	32	120	44	53	62	10	M16x1	Long

Shrink fit holder 4.5° version with and without „Cool Tool“

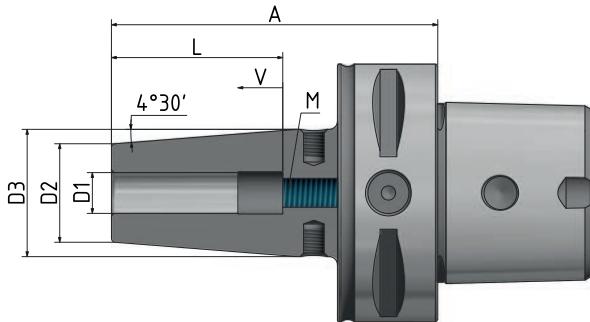

Fig. shows A = 120

Version without „Cool Tool“:

Order No.	C	D1	A	D2	D3	L	V	M1	Version
306321-61	6	6	160	21	27	36	10	M5	Extra long
306321-62	6	8	160	21	27	36	10	M6	Extra long
306321-63	6	10	160	24	32	42	10	M8x1	Extra long
306321-64	6	12	160	24	32	47	10	M10x1	Extra long
306321-65	6	14	160	27	34	47	10	M10x1	Extra long
306321-66	6	16	160	27	34	50	10	M12x1	Extra long
306321-67	6	18	160	33	42	50	10	M12x1	Extra long
306321-68	6	20	160	33	42	52	10	M16x1	Extra long
306321-69	6	25	160	44	52	58	10	M16x1	Extra long
306321-70	6	32	160	44	53	62	10	M16x1	Extra long

Version „Cool Tool“:

Order No.	C	D1	A	D2	D3	L	V	M1	Version
306321-019	6	6	80	21	27	36	10	M5	Short
306321-029	6	8	80	21	27	36	10	M6	Short
306321-039	6	10	80	24	32	42	10	M8x1	Short
306321-049	6	12	80	24	32	47	10	M10x1	Short
306321-059	6	14	85	27	34	47	10	M10x1	Short
306321-069	6	16	85	27	34	50	10	M12x1	Short
306321-079	6	18	85	33	42	50	10	M12x1	Short
306321-089	6	20	85	33	42	52	10	M16x1	Short
306321-319	6	6	120	21	27	36	10	M5	Long
306321-329	6	8	120	21	27	36	10	M6	Long
306321-339	6	10	120	24	32	42	10	M8x1	Long
306321-349	6	12	120	24	32	47	10	M10x1	Long
306321-369	6	16	120	27	34	50	10	M12x1	Long
306321-389	6	20	120	33	42	52	10	M16x1	Long

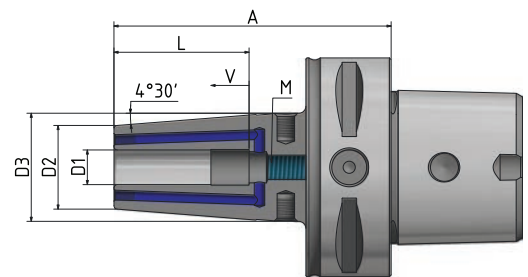

CORUM C8

Shrink fit holder 4,5° (Continuation)

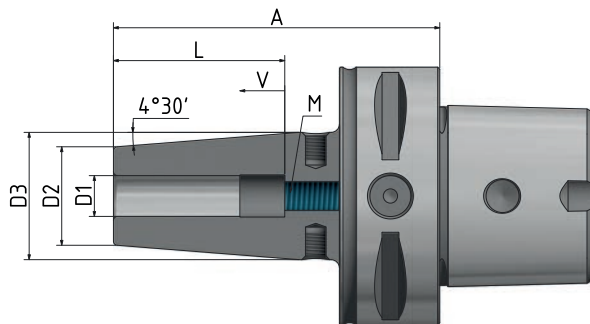

Order No.	C	D1	A	D2	D3	L	V	M1	Version
308021-01	8	6	80	21	27	36	10	M5	Short
308021-02	8	8	80	21	27	36	10	M6	Short
308021-03	8	10	80	24	32	42	10	M8x1	Short
308021-04	8	12	80	24	32	47	10	M10x1	Short
308021-05	8	14	85	27	34	47	10	M10x1	Short
308021-06	8	16	85	27	34	50	10	M12x1	Short
308021-07	8	18	85	33	42	50	10	M12x1	Short
308021-08	8	20	85	33	42	52	10	M16x1	Short
308021-09	8	25	90	44	52	58	10	M16x1	Short
308021-10	8	32	95	44	53	62	10	M16x1	Short

Shell mill holder „Cool Tool“

Application: For adapting shell mills with transverse slot, with coolant mandrel on the cutting edge.

Technical Design: With extended flange.
Runout of outer taper to $D1 \leq 0,006$ mm.

Includes: Clamping screw and drive keys.

Accessories: See page 189.

FINE BALANCED
G 2,5 at 25.000^{min}-1 or max.
residual imbalance ≤ 1 gmm

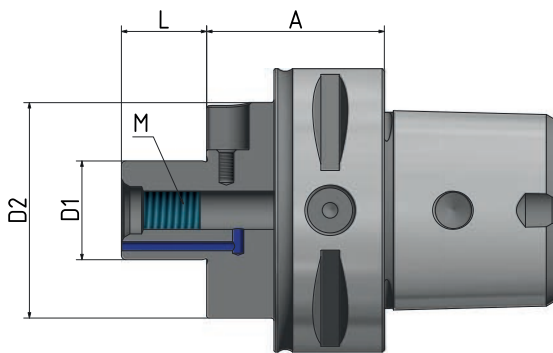

Order No.	C	D1	A	D2	L1	M	Version
304005-21	4	16	32	38	17	M8	Short
304005-22	4	22	25	48	19	M10	Short

Order No.	C	D1	A	D2	L1	M	Version
305005-21	5	16	35	38	17	M8	Short
305005-22	5	22	25	48	19	M10	Short
305005-23	5	27	25	60	21	M12	Short
305005-24	5	32	40	63	24	M16	Short

Order No.	C	D1	A	D2	L1	M	Version
306305-21	6	16	40	38	17	M8	Short
306305-22	6	22	25	48	19	M10	Short
306305-23	6	27	25	60	21	M12	Short
306305-24	6	32	25	63	24	M16	Short
306305-211	6	16	65	38	17	M8	Short
306305-221	6	22	65	48	19	M10	Short
306305-231	6	27	65	60	21	M12	Short
306305-241	6	32	65	63	24	M16	Short

Order No.	C	D1	A	D2	L1	M	Version
308005-21	8	16	50	38	17	M8	Short
308005-22	8	22	50	48	19	M10	Short
308005-23	8	27	50	60	21	M12	Short
308005-24	8	32	60	63	24	M16	Short
308005-25	8	40	60	89	27	M20	Short

ACCESSORIES AND SPARE PARTS

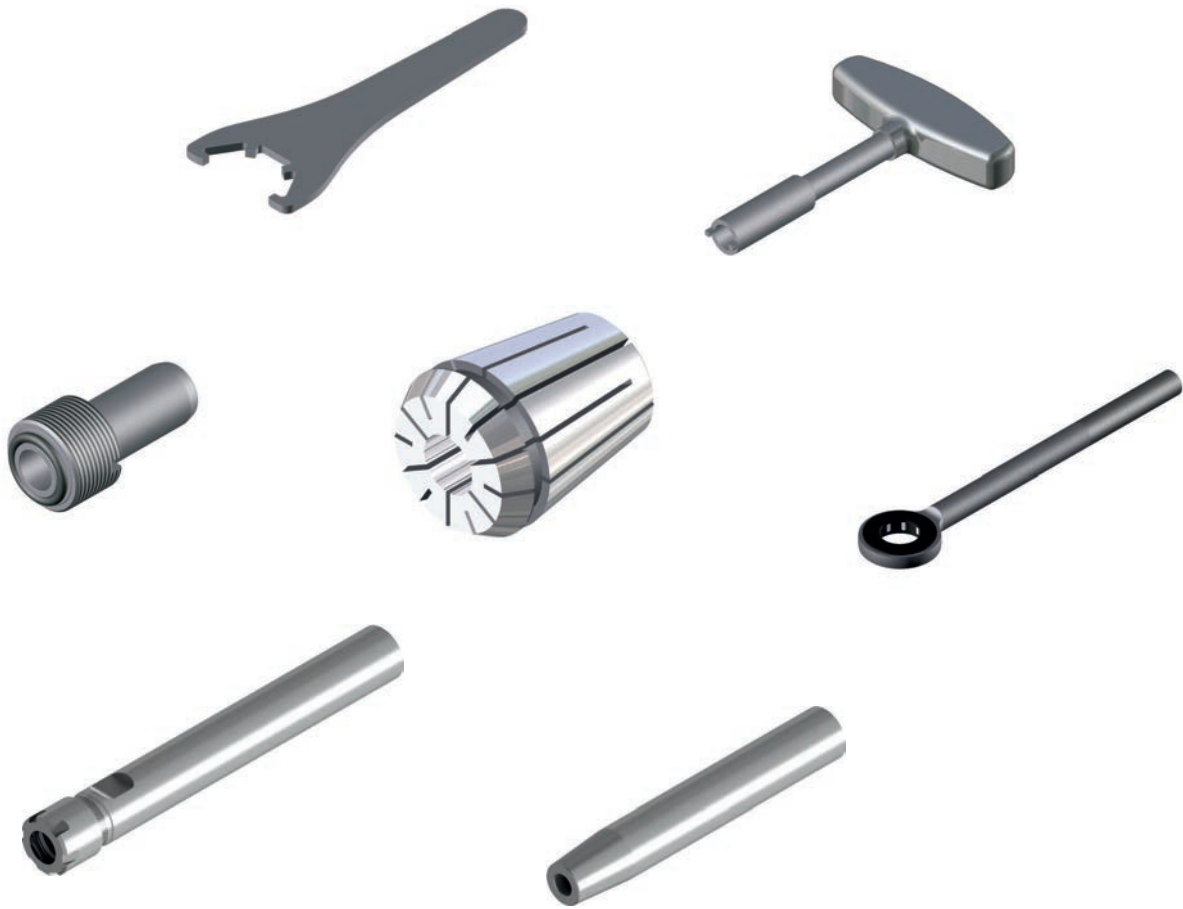

Collet chuck extensions „Mini“ (with trough hole)

Application: For the extension of tool holders.
Cylindrical shank can be clamped in end mill holder or collet chuck.

Technical Design: Runout of inner taper to shaft $D \leq 0,005$ mm.

Includes: Clamping nut.

Accessories: See page 163.

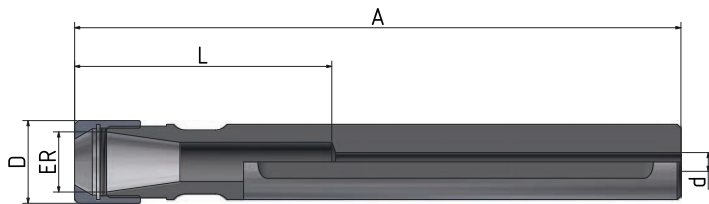

Order No.	ER	D	D1	A	L	d
119-49	11	16	16	169	56	5
119-50	16	22	20	163	70	5
119-51	20	28	25	164	70	6

ER-Collet chuck extensions „Mini“ – without clamping surface (cylindrical)

Application: For the extension of tool holders.

Technical Design: Runout of inner taper to shaft $D \leq 0,005$ mm.

Includes: Clamping nut.

Accessories: See page 163.

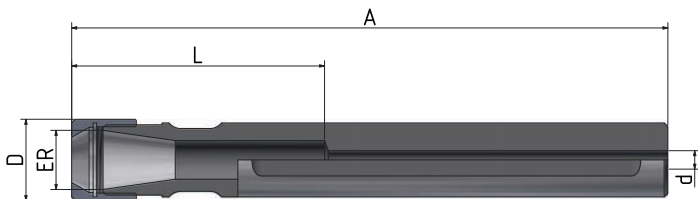

Order No.	ER	D	D1	A	L	d
119-69	11	16	16	169	56	5
119-70	16	22	20	163	70	5
119-71	20	28	25	164	70	6

SHRINK FIT EXTENSIONS

Shrink fit extensions without length adjustment screw

Application: For the extension of tool holders.
Cylindrical shank can be clamped in shrink fit holder or collet chuck.

Technical Design: Made of special heat resistant steel. Suitable for inductive shrinking unit.
Runout of outer taper to $D1 \leq 0,003$ mm.

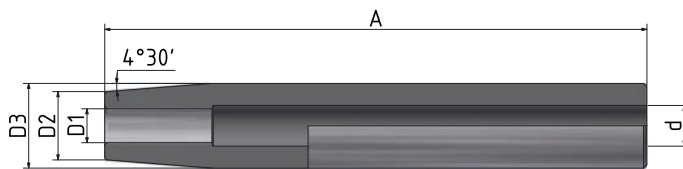

Order No.	D3	D1	D2	A	d
2112-13	12	3	8	160	4,5
2112-14	12	4	8	160	5
2112-01	12	6	10	160	7
2116-13	16	3	10	160	5
2116-14	16	4	10	160	5
2116-15	16	5	10	160	6
2116-01	16	6	10	160	7
2116-02	16	8	14	160	9
2120-15	20	5	14	160	8
2120-01	20	6	14	160	8
2120-02	20	8	14	160	9
2125-02	25	8	19	160	10
2125-03	25	10	20	160	12
2125-04	25	12	20	160	14
2125-05	25	14	20	160	16
2125-06	25	16	22	160	17
2132-03	32	10	24	160	12
2132-04	32	12	24	160	14
2132-05	32	14	27	160	16
2132-06	32	16	27	160	18
2132-07	32	18	27	160	20
2132-08	32	20	27	160	22

Order No.	D3	D1	D2	A	d
2112-313	12	3	8	210	4,5
2112-314	12	4	8	210	5
2116-313	16	3	10	210	5
2116-314	16	4	10	210	5
2116-31	16	6	10	210	7
2120-31	20	6	14	210	8
2120-32	20	8	14	210	9

Order No.	D3	D1	D2	A	d
2120-61	20	6	14	300	8
2120-62	20	8	14	300	9
2125-62	25	8	19	300	10
2125-63	25	10	20	300	12
2125-64	25	12	20	300	14
2125-65	25	14	20	300	16
2125-66	25	16	22	300	17
2132-63	32	10	24	300	12
2132-64	32	12	24	300	14
2132-65	32	14	27	300	16
2132-66	32	16	27	300	18
2132-68	32	20	27	300	22

Shrink fit extensions „Cool Tool“ without length adjustment screw

Application: For the extension of tool holders.
Cylindrical shank can be clamped in shrink fit holder or collet chuck.

Technical Design: Made of special heat resistant steel. Suitable for inductive shrinking unit.
Runout of outer taper to $D1 \leq 0,005$ mm.

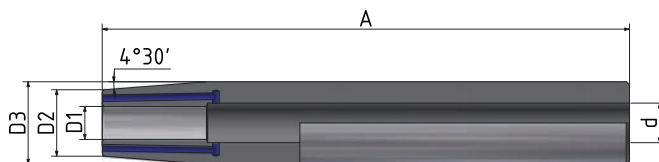

Order No.	D3	D1	D2	A	d
2120-019	20	6	14	160	8
2125-029	25	8	19	160	10
2125-039	25	10	20	160	12
2132-039	32	10	24	160	12
2132-049	32	12	24	160	14
2132-059	32	14	27	160	16
2132-069	32	16	27	160	18

SHRINK FIT EXTENSIONS

Shrink fit extensions with length adjustment screw

Application: For the extension of tool holders.
Cylindrical shank can be clamped in shrink fit holder or collet chuck.

Technical Design: Made of special heat resistant steel. Suitable for inductive shrinking unit.
Runout of outer taper to $D1 \leq 0,003$ mm.

Includes: Set screw.

Accessories: see page 167.

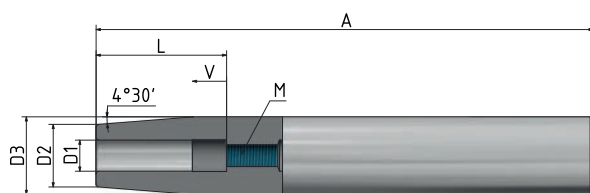

Order No.	D3	D1	D2	A	V	L	M
211621-01	16	6	10	160	10	37	M5
212021-01	20	6	14	160	10	37	M5
212021-02	20	8	14	160	10	37	M6
212521-02	25	8	19	160	10	37	M6
212521-03	25	10	20	160	10	42	M8x1
212521-04	25	12	20	160	10	48	M10x1
212521-05	25	14	20	160	10	48	M10x1
212521-06	25	16	22	160	10	51	M12x1
213221-03	32	10	24	160	10	42	M8x1
213221-04	32	12	24	160	10	48	M10x1
213221-05	32	14	27	160	10	48	M10x1
213221-06	32	16	27	160	10	51	M12x1
213221-07	32	18	27	160	10	51	M12x1
213221-08	32	20	27	160	10	53	M16x1

Pull stud DIN 69872 Form A, with through hole

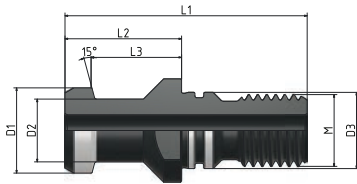

Order No.	SK	D1	D2	D3	L1	L2	L3	M
7124-01	40	19	14	17	54	26	20	M16
7124-21	50	28	21	25	74	34	25	M24

Pull stud DIN 69872 Form B, without through hole, with O-Ring on the collar

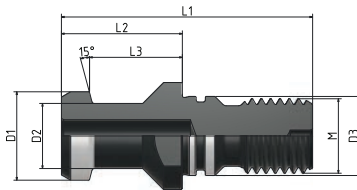

Order No.	SK	D1	D2	D3	L1	L2	L3	M
7124-01B	40	19	14	17	54	26	20	M16
7124-21B	50	28	21	25	74	34	25	M24

Pull stud ISO 7388 B with through hole

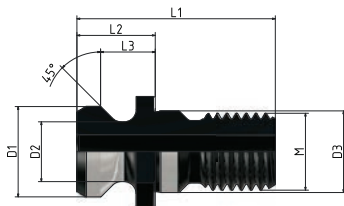

Order No.	SK	D1	D2	D3	L1	L2	L3	M
7425-11	40	18,95	12,95	17	44,5	16,4	11,5	M16
7425-31	50	29,1	19,6	25	65,5	25,55	17,95	M24

Pull stud ISO 7388 B without through hole, with O-Ring on the collar

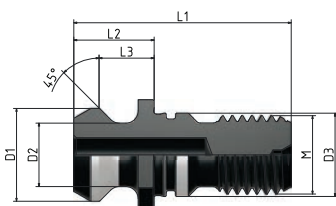

Order No.	SK	D1	D2	D3	L1	L2	L3	M
7425-11B	40	18,95	12,95	17	44,5	16,4	11,5	M16
7425-31B	50	29,1	19,6	25	65,5	25,55	17,95	M24

PULL STUD

Pull stud MAS 403 30° and 45°

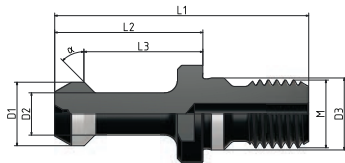

Order No.	BT	Grad	D1	D2	D3	L1	L2	L3	M
7525-51	30	30	11	7	12,5	43	23	18	M12
7524-11	40	45	15	10	17	60	35	28	M16
7524-01*	40	45	15	10	17	57,2	32,2	25,2	M16
7525-11	40	30	15	10	17	60	35	28	M16
7524-31	50	45	23	17	25	85	45	35	M24
7525-31	50	30	23	17	25	85	45	35	M24

* BT 40 45° 3 mm shortened.

Pull stud Mori-Seiki MAS 90°

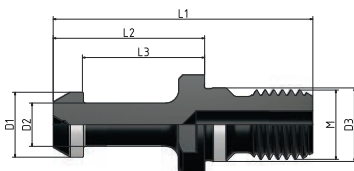

Order No.	BT	D1	D2	D3	L1	L2	L3	M
7526-11	40	15	10	17	60	35	28	M16
7526-31	50	23	17	25	85	45	35	M24

Pull stud JIS B 6339 with through hole

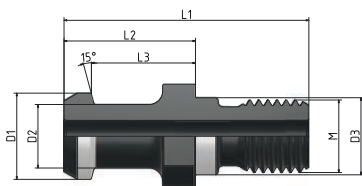

Order No.	BT	D1	D2	D3	L1	L2	L3	M
7528-11	40	19	14	17	54	29	23	M16
7528-31	50	28	21	25	74	34	25	M24

Pull stud ANSI-CAT 40 (Mazak) with through hole and sealing at the end face

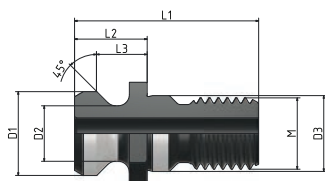

Order No.	SK	D1	D2	D3	L1	L2	L3	M
7424-62	40	18,796	12,446	17	41,3	16,3	11,2	M16
Order No.	BT	D1	D2	D3	L1	L2	L3	M
7424-61*	40	18,796	12,446	17	44,106	19,106	14,03	M16

* 3mm extended.

Pull stud ANSI-CAT 50 (Mazak) with through hole and recess for O-Ring

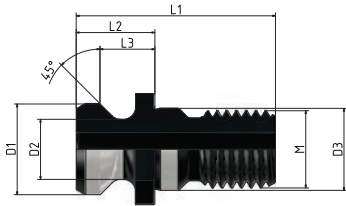

Order No.	SK	D1	D2	D3	L1	L2	L3	M
7424-31	50	28,95	20,82	25	65,4	25,4	17,78	M24

Pull stud Ott-Ringnut with through hole

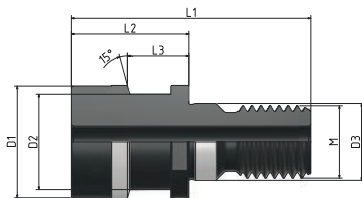

Order No.	SK	D1	D2	D3	L1	L2	L3	M
7125-41	40	25	21,1	17	53	25	13,6	M16
7125-42	50	39,3	32	25	65	25	13,35	M24

Pull stud Ott-Ringnut without through hole, sealed

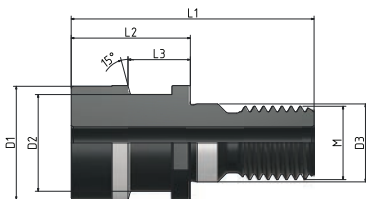

Order No.	SK	D1	D2	D3	L1	L2	L3	M
7125-46	40	25	21,1	17	53	25	13,6	M16
7125-47	50	39,3	32	25	65	25	13,35	M24

Pull stud Ott-Ringnut with internal thread

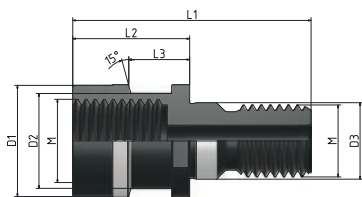

Order No.	SK	D1	D2	D3	L1	L2	L3	M
7125-11	40	25	21,1	17	53	25	13,6	M16
7125-12	50	39,3	32	25	65	25	13,35	M24

PULL STUD

Pull stud with thread S20x2

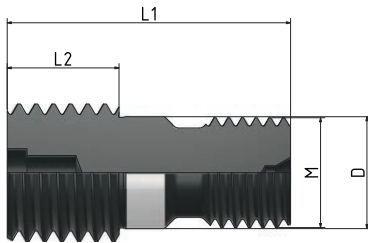

Order No.	SK	D	L1	L2	M
7428-01	40	17	41,3	16,3	M16

HSK coolant tube

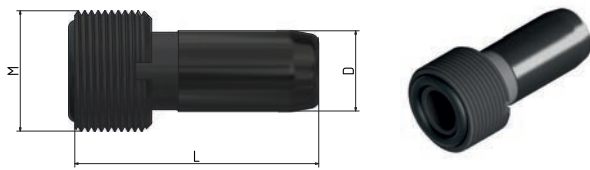

Order No.	HSK	M	D	L
603224	32	M10x1	6	26
604024	40	M12x1	8	29
605024	50	M16x1	10	33
606324	63	M18x1	12	36,5
608024	80	M20x1,5	14	39,5
610024	100	M24x1,5	16	43,5

Wrench for HSK coolant tube



Order No.	HSK
603225	32
604025	40
605025	50
606325	63
608025	80
610025	100

PSC Coolant tube CORUM

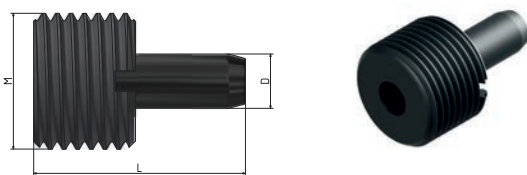

Order No.	C	M	D	L
304024	4	M14x1,5	6	25,2
305024	5	M16x1,5	7	28,3
306324	6	M20x2	8	31,0
308024	8	M20x2	10	31,5

Wrench f. coolant tube CORUM ISO 22402-02

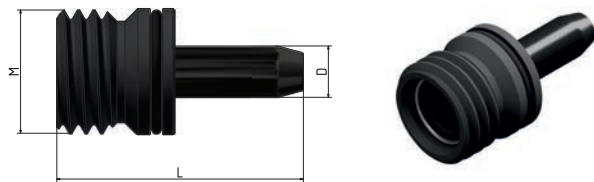

Order No.	C	M	D	L
303224-30	3	M12x1,5	5	24
304024-30	4	M14x1,5	6	27,5
305024-30	5	M16x1,5	7	29,5
306324-30	6	M20x2	8	33,5
308024-30	3	M20x2	10	34,5

Wrench for coolant tube CORUM
+ CORUM ISO 22402-2



Order No.	C	Order No.	C
304025	4	304025-30	4
305025	5	305025-30	5
306325	6	306325-30	6
308025	8	308025-30	8

Taper cleaner



Order No.	HSK
228032	32
228040	40
228050	50
228063	63
228080	80
228100	100

ACCESSORIES

ER-Collets, repeatable accuracy 5μ



- High precision design with concentricity and repeat accuracy of 5 μ.
- All lengthwise edges deburred and rounded additionally. This protects the inner cone of the chuck and provides consistently high concentricity.
- Increased holding forces and rigidity by super-finish-version.

Order No.	ER	Diameter	Increasing
124-0xxx	11	1,0–7,0	0,5
124-1xxx	16	1,0–10,0	0,5
124-2xxx	20	1,0–13,0	0,5
124-3xxx	25	1,0–16,0	0,5
		17,0	1
124-4xxx	32	2,0–21,0	0,5
		22,0	1
124-5xxx	40	3,0–26,0	0,5
		27,0–30,0	1

Please complete the item number with the respective diameter of the collet, i.e. ER 16 with Ø 2,5 = 124-1025.

ER-Collet set, repeatable accuracy 5μ



Order No.	ER	Drm.	increasing	Piece/Set
124-0S	11	1,0-7,0	0,5	13
124-1S	16	1,0-10,0	1	10
124-2S	20	2,0-13,0	1	12
124-3S	25	2,0-16,0	1	15
124-4S	32	3,0-20,0	1	18
124-5S	40	4,0-26,0	1	23

ER-Collets, repeatable accuracy 2μ



- High precision design with concentricity and repeat accuracy of 2 μ.
- All lengthwise edges deburred and rounded additionally. This protects the inner cone of the chuck and provides consistently high concentricity.
- Increased holding forces and rigidity by super-finish-version.

Order No.-Nr.	ER	Drm.	steigend
131-0xxx	11	1,0–6,0	1
131-1xxx	16	1,0–6,0	1
		8,0+10,0	1
131-3xxx	25	1,0–6,0	1
		8,0+10,0	1
		12,0+14,0+16,0	1
131-4xxx	32	2,0–6,0	1
		8,0+10,0	1
		12,0+14,0	1
		16,0+18,0	1
		20,0	1

Please complete the item number with the respective diameter of the collet, i.e. ER 16 with Ø 6,0 = 131-106

Sealed ER-Collets with jet nozzels „Cool Tool“ – repeatable accuracy of collet 5 μ

- Highest runout accuracy combined with effective cooling and chip removal.
- Applicable up to 120 bar.
- Only shanks with nominal size can be used, tolerance h8.
- Shanks with lateral clamping flat can only be used limited. Which means the clamping flat has to be behind the sealing plug, otherwise the coolant can leak along the shank.



fig.: Collet with jet nozzels „Cool Tool“ for tool holders without internal cooling.

Order No.	ER	Diameter
129-1xx	16	3–10
129-2xx	20	3–13
129-3xx	25	6–16
129-4xx	32	6–20
129-5xx	40	6+8+10–26

Please complete the item number with the respective diameter of the collet, i.e. ER 25 with $\varnothing 8 = 129-308$.

Sealed ER-Collets – repeatable accuracy of collet 5 μ

- For tools with internal coolant up to 120 bar!
- Only shanks with standard dimensions can be used, tolerance h8.
- Shanks with lateral clamping flat can only be used limited, which means the clamping flat has to be behind the sealing plug, otherwise the coolant can leak along the shank.



fig.: internal cooling with sealed collet.

Order No.	ER	Diameter
128-0xx	11	3–7
128-1xx	16	3–10
128-2xx	20	3–13
128-3xx	25	6–16
128-4xx	32	6–20
128-5xx	40	6+8–26

Please complete the item number with the respective diameter of the collet, i.e. ER 25 with $\varnothing 10 = 128-310$.

ACCESSORIES FOR INTERNAL COOLANT FOR ER COLLET CHUCKS

Sealable ER clamping nuts

- for using with sealing discs, for sealing conventional ER-collets.
- for tools with internal cooling up to 100 bar.



Order No.	ER	KW
107-21	16	25
107-31	20	30
107-41	25	-
107-51	32	-
107-61	40	-

Please note:

Sealable clamping nuts are 5 mm longer than regular clamping nuts.
Due to this the overall length of the chucks also increases by 5 mm.

Sealing discs for sealable ER clamping nuts



The sealing discs are available in steps of 0,5 mm.
This means, the discs can cover a range of 0,4 mm from normal size shank down to smaller diameters. For example, to clamp a drill of dia. 5,7 a disc of the size 6 mm will be used.

Please note! For high pressure of 100 bar, the size of the shank has to be the same as the nominal size of the disc.

For ordering please complete the item number with the diameter of the disc,

- i.e.: sealing disc for ER 25 with diameter 5,5 = 107-41055
- i.e.: sealing disc for ER 32 with diameter 12 = 107-5112

Order No.	ER
107-21xxx	16
107-31xxx	20
107-41xxx	25
107-51xxx	32
107-61xxx	40

ER-Collet secuRgrip®



Order No.	ER	D
125-410	32	10
125-412	32	12
125-416	32	16
125-516	40	16
125-520	40	20
125-525	40	25

ER thread insert secuRgrip®

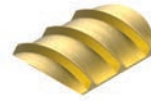

Order No.	D
136-10	10
136-12	12
136-16	16
136-20	20
136-25	25

Ball bearing wrench attachment ER
HAWK EYE® – square drive



Order No.	VK	ER
163-42	9x12	16
163-43	14x18	20
163-44	14x18	25
163-45	14x18	32
163-46	14x18	40

Ball bearing wrench attachment ER
HAWK EYE® „Mini“ – square drive



Order No.	VK	ER
163-91	9x12	16
163-92	14x18	20

Torque wrench for ball bearing wrench



Order No.	VK	Nm
163-83	9x12	10-60
163-85	14x18	40-200

Ball bearing wrench ER one-piece HAWK EYE®



Order No.	ER
163-12	16
163-13	20
163-14	25
163-15	32
163-16	40

Ball bearing wrench attachment ER
HAWK EYE® „Mini“ – one piece



Order No.	ER
163-21	16
163-22	20

ACCESSORIES

Wrench ER



Order No.	ER	SW
162-02	11	17
162-03	16	25
162-04	20	30
162-05	25	-
162-06	32	-
162-07	40	-

Wrench ER „Mini“



Order No.	ER
162-22	11
162-23	16
162-24	20
162-25	25

Round clamping nut HAWK EYE®, with ball bearing

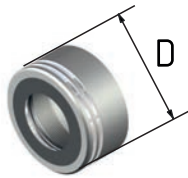

Order No.	ER	D	M
137-02R	16	34	M24x1
137-03R	20	38	M28x1
137-04R	25	44	M34x1
137-05R	32	52	M42x1
137-06R	40	62	M52x1

Round clamping nut HAWK EYE®, one piece

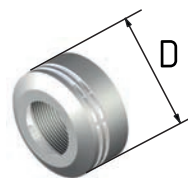

Order No.	ER	D	M
137-42R	16	34	M24x1
137-44R	25	44	M34x1
137-45R	32	52	M42x1
137-46R	40	62	M52x1
137-01M*	11	16	M14x0,75
137-02M*	16	24	M20x1

* Clamping nut „Hawk Eye“ – ER Mini

Nuts ER

Order No.	ER	SW	Fig.	D	M
107-10	11	17	1	19	M14x0,75
107-20	16	25	1	28	M22x1,5
107-30	20	30	1	34	M25x1,5
107-40	25	-	2	42	M32x1,5
107-50	32	-	2	50	M40x1,5
107-60	40	-	2	63	M50x1,5

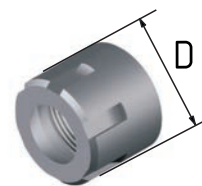

Fig. 1



Fig. 2

Nuts ER „Mini“



Order No.	ER	D	M
107-10M	11	16	M13x0,75
107-20M	16	22	M19x1
107-30M	20	28	M24x1
107-40M	25	35	M30x1

Clamping screw for endmill holder weldon
DIN 1835B



Order No.	for Ø	Thread
235-02	6	M6
235-03	8	M8
235-04	10	M10
235-05	12+14	M12
235-06	16+18	M14
235-07	20	M16
235-08	25	M18x2
235-09	32	M20x2

Plug screw for Cool Tool bore



Order No.	for Ø	Thread
242-01	6-32	M3

Clamping screw for Whistle Notch DIN 1835E



Order No.	for Ø	Thread
237-01	6	M5
237-02	8	M6
237-03	10	M8
237-04	12	M10
237-05	14	M10
237-06	16	M12
237-07	18	M12
237-08	20	M16
237-09	25+32	M20



Order No.	for ER	M
238-21	11	M8x1x10
238-22	16	M11x1x12
238-23	20	M14x1x13
238-24	25	M18x1,5x14
238-25	32	M24x1,5x16
238-26	40	M28x1,5x18

Length adjustment screw for Whistle Notch
(for internal coolant)

Length adjustment screw for shrink fit holder
(for internal coolant)



Order No.	for Ø	Thread
238-01	6	M5
238-02	8	M6
238-03	10	M8x1
238-04	12+14	M10x1
238-06	16+18	M12x1
238-08	20+25+32	M16x1



Order No.	for Ø	Thread
235-02	6	M6
235-03	8	M8
235-04	10	M10
235-05	12+14	M12
235-06	16+18	M14
235-07	20	M16
235-08	25	M18x2
235-09	32	M20x2

Length adjustment screw for shrink fit holder
„Cool Tool“ (for internal coolant)



Order No.	for Ø	Thread
238-11	6	M5
238-12	8	M6
238-13	10	M8x1
238-14	12+14	M10x1
238-16	16+18	M12x1
238-18	20+25+32	M16x1

ACCESSORIES AND SPARE PARTS

Wrench for shell mill holder



Order No.	for Ø
226-03	16
226-04	22
226-05	27
226-06	32
226-07	40
226-08	50
226-09	60

Clamping screw for shell mill holder



Order No.	for Ø	Thread
225-03	16	M8
225-04	22	M10
225-05	27	M12
225-06	32	M16
225-07	40	M20
225-08	50	M24
225-09	60	M30

Drive key half-round for shell mill holder



Order No.	for Ø
240-51	16
240-52	22
240-53	27
240-54	32
240-55	40

Drive key for shell mill holder



Order No.	for Ø	Order No.	SK40 short for Ø
240-01	16	240-43	27
240-02	22		
240-03	27		
240-04	32		
240-05	40		
240-07	60		

Drive key screws



Order No.	for Ø	M
240-31	16	M3
240-32	22	M4
240-33	27	M4
240-34	32	M5
240-35	40	M5
240-37	60	M12

Wrench for combi shell mill holder



Order No.	for Ø
226-03	16
226-04	22
226-05	27
226-06	32
226-07	40

Clamping screw for combi shell mill holder



Order No.	for Ø	Thread
225-03	16	M8
225-04	22	M10
225-05	27	M12
225-06	32	M16
225-07	40	M20

Drive key for shell mill holder CORUM



Order No.	C4 for Ø
240-01	16
240-02	22
C5 for Ø	
240-01	16
240-02	22
240-43	27
240-44	32
C6 for Ø	
240-01	16
240-02	22
240-43	27
240-44	32



C8 for Ø	
240-51	16
240-52	22
240-53	27
240-54	32

Adjustment spring



Order No.	for Ø
223-02	16
223-03	22
223-04	27
223-05	32
223-06	40

Drive key for combi shell mill holder



Order No.	for Ø
224-03	16
224-04	22
224-05	27
224-06	32
224-07	40

HOW TO REACH US



Continue on the A81 to Singen coming from the north and from the west on the A81 to the south of Stuttgart. Exit A81 to Rottenburg. Drive towards from Rottenburg to Hechingen and Bodelshausen.

Coming from the east, exit the A8 at Stuttgart Airport and follow the B27 towards Tübingen. Exit the B27 at Bodelshausen.

Coming from the south, exit the A8 at Empfingen and follow the direction to Haigerloch. From Haigerloch further towards to Hechingen and Bodelshausen.

In Bodelshausen you will find us directly at the local main road Bahnhofstraße 108.



Karl Schüssler GmbH & Co. KG
Bahnhofstraße 108
D-72411 Bodelshausen
Phone: +49 74 71 / 95 90-0
info@k-schuessler.de



V09072024

SCHÜSSLER
the μ -maker

© Karl Schüssler GmbH & Co. KG, 2024